

Compact Cassette Datasheets

Visa Superchrom UCX II-S



I measured MOLs at 11 points from 20 Hz to 1 kHz with a distortion limit of 3%, and measured saturation output levels (SOLs) at nine points from 1 to 16 kHz. I used a Nakamichi 582 deck for substantially all of the record/playback tests. The three Tables list the MOL (3% distortion limit) at 40, 125, and 800 Hz. I selected 40 Hz because it lies in a frequency region important in music for organ and other sources of low-frequency energy. The Tables also present SOL data for 2, 4, and 10 kHz. The SOL curves were very similar in shape, particularly within a tape type. Other data: <https://www.elektronikjk.com>

Maximum Output Level (dB, re: Dolby Level: 200 nWb/m at 400 Hz)

MOL hdl3 = 3%			SOL		
40 Hz	125 Hz	800 Hz	2 kHz	4 kHz	10 kHz
-3.7	+ 1.7	+ 1.4	+ 3.2	-0.5	-7.4

S/N Ratio (dBA):59.3
Response Limit (-3 dB) at Dolby Level (kHz):6.4
Modulation noise (dB):-50.2
Bias (dB):-0.1
Sensitivity (dB):-1.2

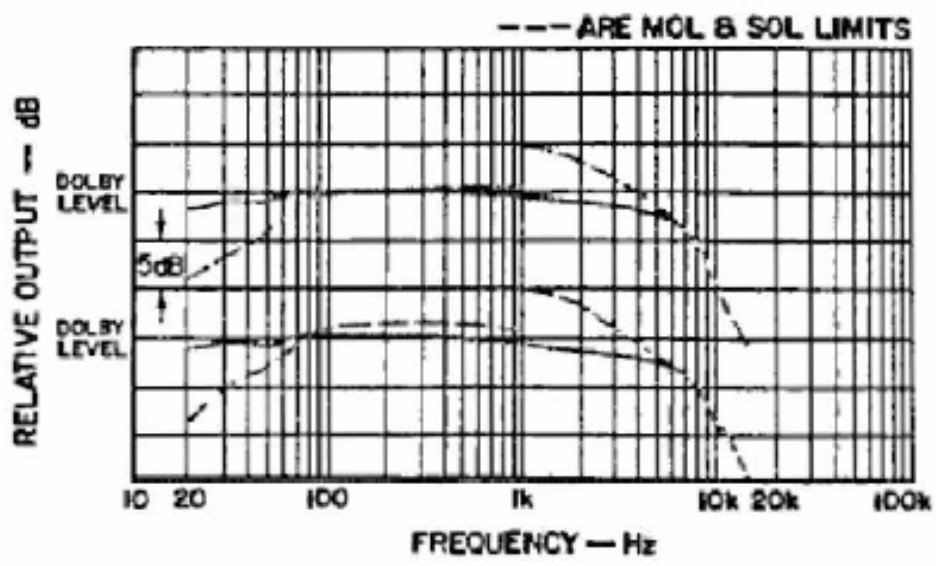

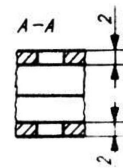
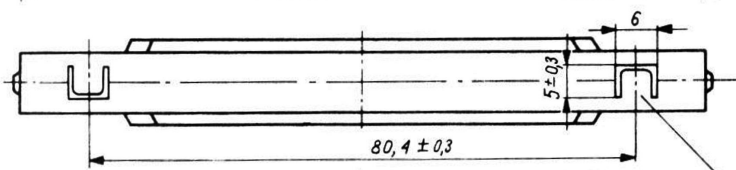
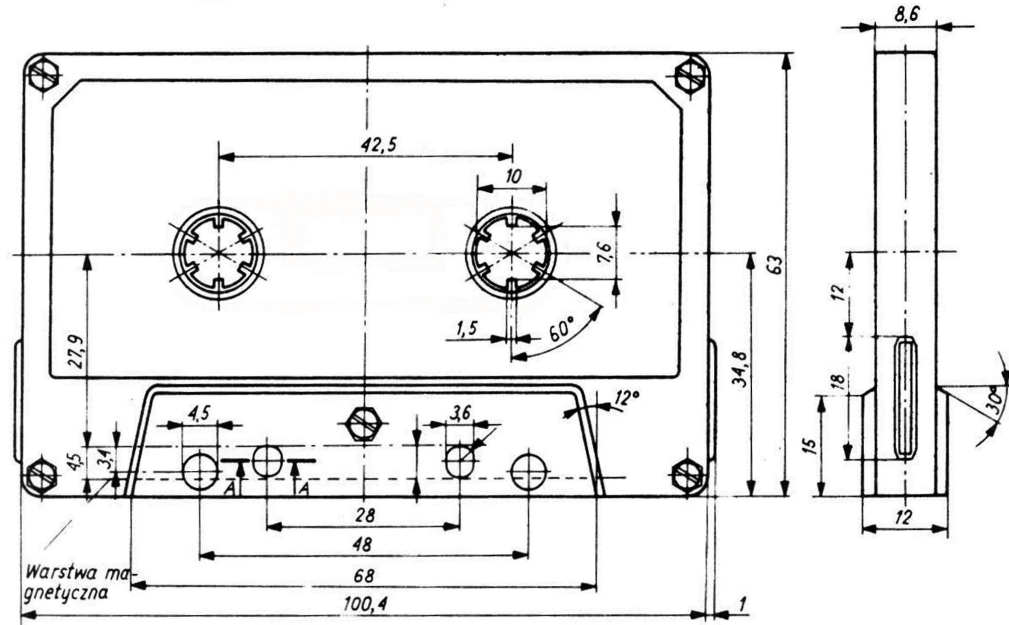
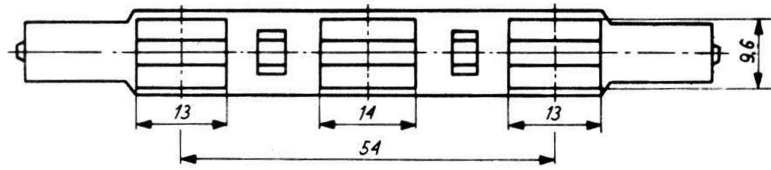

Językzek kasujący

