



4127

## LOGARITHMIC AMPLIFIER

### FEATURES

- ACCEPTS INPUT VOLTAGES OR CURRENTS OF EITHER POLARITY
- WIDE INPUT DYNAMIC RANGE  
6 Decades of Current  
4 Decades of Voltage
- VERSATILE  
Log, Antilog, and Log Ratio Capability

### DESCRIPTION

Packaged in a ceramic double wide DIP, the 4127 is the first hybrid logarithmic amplifier that accepts signals of either polarity from current or voltage sources. A special purpose monolithic chip, developed specifically for logarithmic conversions, functions accurately for up to six decades of input

current and four decades of input voltage. In addition, a current inverter and a precise internal reference allow pin programming of the 4127 as a logarithmic, log ratio, or antilog amplifier.

To further increase its versatility and reduce your system cost, the 4127 has an uncommitted operational amplifier in its package that can be used as a buffer, inverter, filter, or gain element.

The 4127 is available with initial accuracies (log conformity) of 0.5% and 1.0%, and operates over an ambient temperature range of  $-10^{\circ}\text{C}$  to  $+70^{\circ}\text{C}$ .

With its versatility and high performance, the 4127 has many applications in signal compression, transducer linearization, and phototube buffering. Manufacturers of medical equipment, analytical instruments, and process control instrumentation will find the 4127 a low cost solution to many signal processing problems.

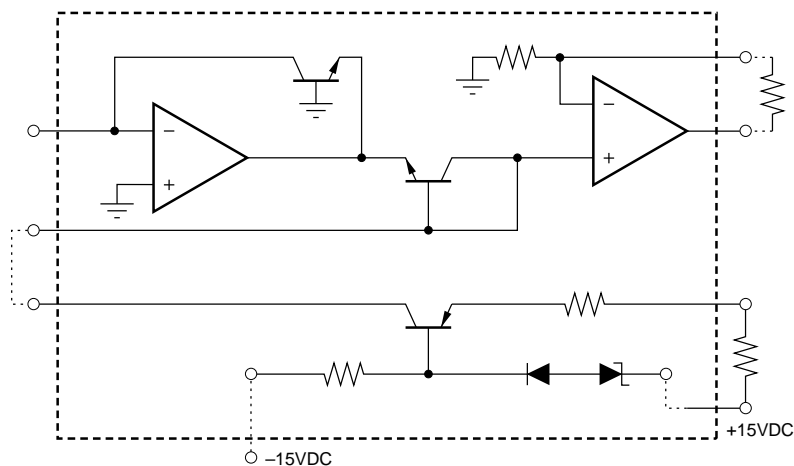

International Airport Industrial Park • Mailing Address: PO Box 11400 • Tucson, AZ 85734 • Street Address: 6730 S. Tucson Blvd. • Tucson, AZ 85706  
Tel: (520) 746-1111 • Twx: 910-952-1111 • Cable: BBRCORP • Telex: 066-6491 • FAX: (520) 889-1510 • Immediate Product Info: (800) 548-6132

# SPECIFICATIONS

## ELECTRICAL

Typical Specifications at +25°C with rated supplies, unless otherwise noted.

MODEL	4127KG	4127JG
<b>ACCURACY<sup>(1)</sup>, % of FSR</b> Current Source Input: 1nA to 1mA Voltage Input: 1mV to 10V	0.5% max 0.5% max	1% max 1% max
<b>INPUT</b> Current Source Input, Pin 4 Current Source Input, Pin 7 Reference Current Input, Pin 2 Absolute Maximum Inputs	+1nA to +1mA -1nA to -1mA +1μA to +1mA ±10mA or ±Supply Volts	
<b>OUTPUT</b> Voltage Current Impedance	±10V ±5mA 10Ω	
<b>FREQUENCY RESPONSE</b> -3dB Small Signal at Current Input of 100μA of 10μA of 1μA of 100nA of 10nA Step Response to within ±1% of Final Value (I <sub>R</sub> = 1μA, A = 5)	90kHz 50kHz 5kHz 250Hz 80Hz 10ms	
<b>STABILITY</b> Scale Factor Drift (ΔA/°C) Reference Current Drift (ΔI <sub>R</sub> /°C) Input Offset Current Drift (ΔI <sub>S</sub> /°C) Input Offset Voltage Drift Accuracy vs Supply Variation Reference Current Input Offset Voltage Input Noise - Current Input Input Noise - Voltage Input	±0.0005A/°C ±0.001 I <sub>R</sub> /°C for I <sub>R</sub> ≥ 1μA ±0.003 I <sub>R</sub> /°C for 400nA < I <sub>R</sub> < 1μA 10pA at +25°C, Doubles Every 10°C ±10μV/°C ±0.001I <sub>R</sub> /V ±300μV/V 1pA, rms, 10Hz to 10kHz 10μA, rms, 10Hz to 10kHz	
<b>UNCOMMITTED OP AMP CHARACTERISTICS</b> Input Offset Voltage Input Bias Current Input Impedance Large Signal Voltage Gain Output Current	5mV 40nA 1MΩ 85dB 5mA	
<b>TEMPERATURE RANGE</b> Specification Operating Storage	0°C to +60°C -10°C to +70°C -55°C to +125°C	
<b>POWER SUPPLY REQUIREMENTS</b> Rated Supply Voltages Supply Voltage Range Supply Current Drain at Quiescent, max at Full Load, max	±15VDC ±14VDC to ±16VDC ±20mA ±26mA	

NOTE: (1) Log conformity at 25°C.

## PIN CONFIGURATION

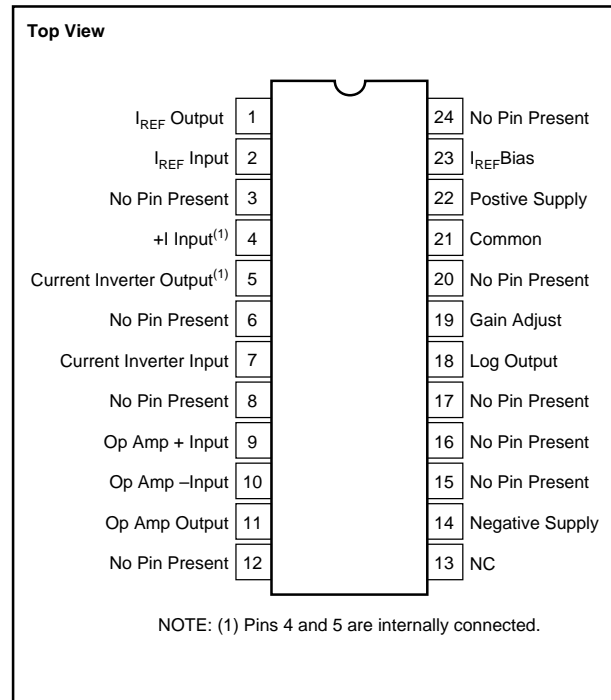

## PACKAGE INFORMATION

MODEL	PACKAGE	PACKAGE DRAWING NUMBER <sup>(1)</sup>
4127KG	24-Pin	075
4127JG	24-Pin	075

NOTE: (1) For detailed drawing and dimension table, please see end of data sheet, or Appendix D of Burr-Brown IC Data Book.

The information provided herein is believed to be reliable; however, BURR-BROWN assumes no responsibility for inaccuracies or omissions. BURR-BROWN assumes no responsibility for the use of this information, and all use of such information shall be entirely at the user's own risk. Prices and specifications are subject to change without notice. No patent rights or licenses to any of the circuits described herein are implied or granted to any third party. BURR-BROWN does not authorize or warrant any BURR-BROWN product for use in life support devices and/or systems.

# TYPICAL PERFORMANCE CURVES

At +25°C with rated supplies, unless otherwise noted.

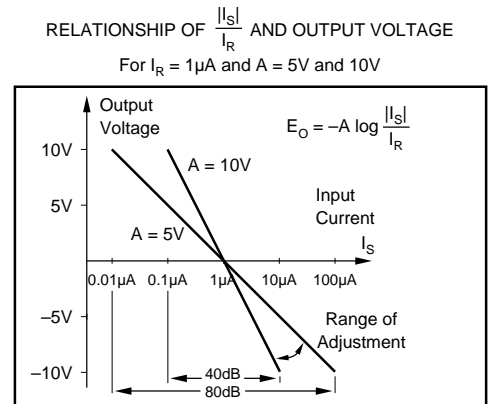
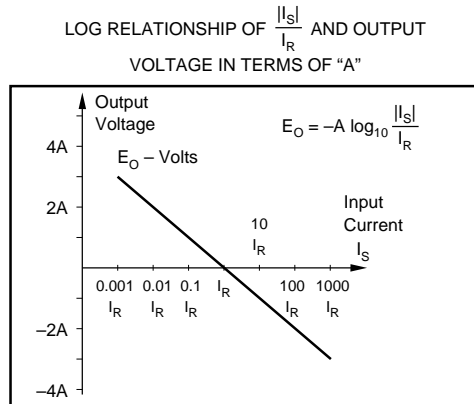
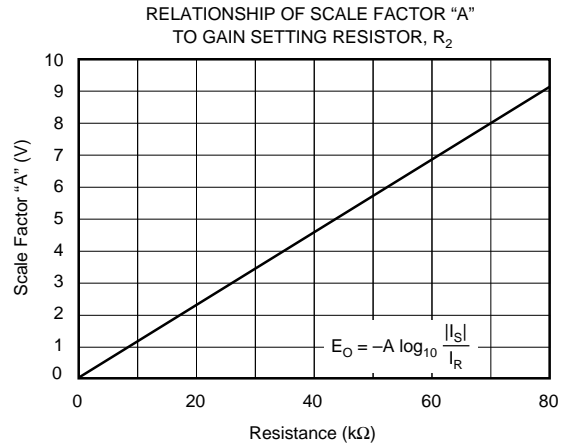
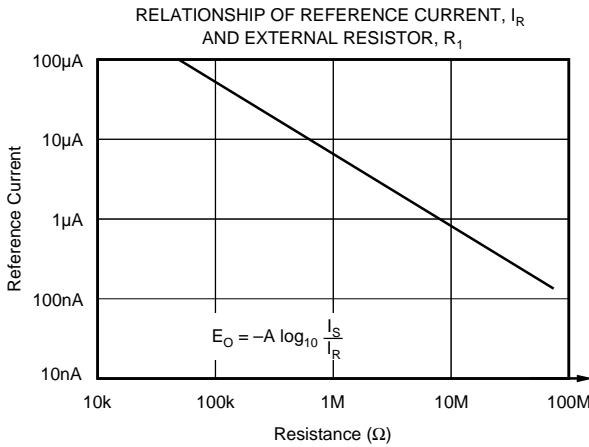

## DISCUSSION OF SPECIFICATIONS

### ACCURACY

The deviation from the ideal output voltage defined as a percent of the full scale output voltage.

### INPUT/OUTPUT RANGE

The log relationships of  $-A \log \frac{I_S}{I_R}$  and  $-A \log \frac{E_S}{I_R R}$  are

subject to the constraints specified. The 4127 can be operated with inputs lower than those given, but the accuracy will be degraded.

### FREQUENCY RESPONSE

The small-signal frequency response varies considerably with signal level and scaling, so the frequency response is specified under several different operating conditions.

### STABILITY

The use of a monolithic transistor quad and low-drift amps minimizes drift, but some drift remains in the scale-factor, reference current, and input offset. Input offset consists of a bias current plus the op amp input voltage offset divided by the signal source resistance. Also, there is some slight drift in conformity to the log function and in output amplifier offset, but this is generally negligible.

## THEORY OF OPERATION

The 4127 is a complete logarithmic amplifier that can be pin-programmed to accept input currents or voltages of either polarity. By making use of the internal current inverter, reference current generator, log ratio element, and uncommitted op amp, you can generate a variety of logarithmic

mic functions, including the log ratio of two signals, the logarithm of an input signal, or the antilog of an input signal. The unique FET-input current-inverting element removes the polarity limitations present in most conventional log amplifiers.

Utilizing the inherent exponential characteristics of transistor functions, the 4127 calculates accurate log functions for input currents from 1nA to 1mA, or input voltages from 1mV to 10V. Carefully matched monolithic quad transistors and temperature sensitive gain elements are used to produce a log amplifier with excellent temperature characteristics.

A functional diagram of the 4127 circuit is shown in Figure 1. In addition to the basic log amplifier, the 4127 contains a separate internal current source, a current inverter, and an uncommitted operational amplifier. The current inverter accurately converts negative input current to a positive current of equal magnitude.

The 4127 is capable of accurately logging input current over a 120dB range, but to use this full range, good shielding practice must be followed. A current source input is, by definition, a high impedance source and is therefore subject to electrostatic pickup.

The input op amps, A<sub>1</sub> and A<sub>3</sub>, have FET input stages for low noise and very-low input bias current. The op amp, A<sub>1</sub>, will make the collector current of Q<sub>1</sub> equal to the signal input current I<sub>S</sub>, and the collector current of Q<sub>2</sub> will be the reference input current I<sub>R</sub>.

From the semiconductor junction characteristics, the base-to-emitter voltage will be:

$$V_{BE} \approx \frac{mKT}{q} \ln \frac{I_C}{I_L}$$

where: I<sub>C</sub> = Collector current  
 I<sub>L</sub> = Reverse saturation current  
 q, m, K = Constants  
 T = Absolute temperature

$$\text{So } E_1 = -\frac{mKT_1}{q} \ln \frac{I_S}{I_{L1}} \text{ and } E_2 - E_1 = \frac{mKT_2}{q} \ln \frac{I_R}{I_{L2}}$$

If the transistors Q<sub>1</sub> and Q<sub>2</sub> are at the same temperature and have matched characteristics, then:

$$E_2 = \frac{mKT}{q} \left[ \ln \frac{I_R}{I_L} - \ln \frac{I_S}{I_L} \right]$$

$$E_2 = \frac{-mKT}{q} \ln \frac{I_S}{I_R}$$

The output op amp, A<sub>2</sub>, provides a voltage gain of approximately (R<sub>T</sub> + R<sub>2</sub>)/R<sub>T</sub>, and the value of (mKT)/q is about 26mV at room temperature. Since resistor R<sub>T</sub> varies with temperature to compensate for gain drift, the output voltage, E<sub>O</sub>, expressed as a log will be:

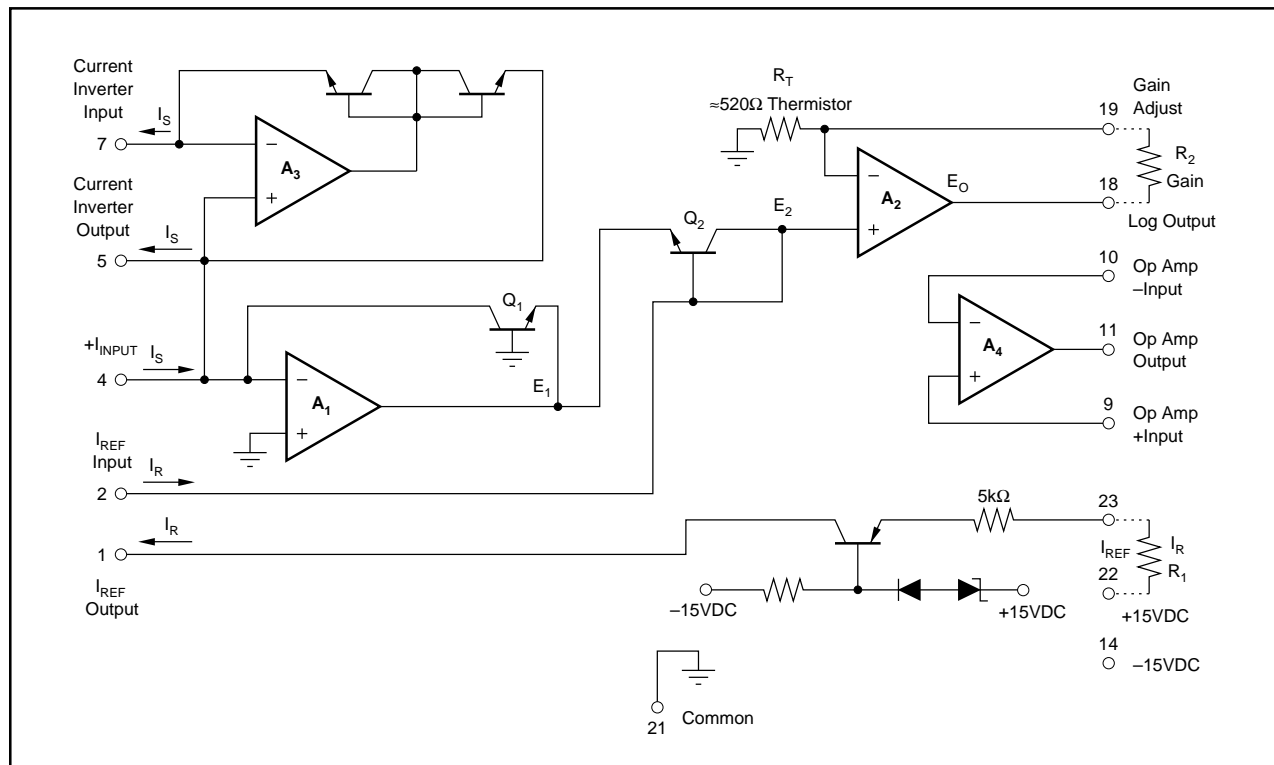

FIGURE 1. Functional Diagram.

$$E_o = -A \log_{10} \frac{I_s}{I_R},$$

$$\text{where } A \approx \frac{R_T + R_2}{R_T} (26\text{mV}) \frac{1}{0.434}, R_T \approx 520\Omega$$

The external resistor  $R_1$  sets the reference current  $I_R$  and resistor  $R_2$  sets the scale-factor "A".  $R_1$  and  $R_2$  must be trimmed to the desired values, but the approximate relationships are shown in Typical Performance Curves.

The relationship between the input current,  $I_s$ , and the output voltage,  $E_o$ , in terms of the externally adjusted parameters,  $I_R$  and "A", is illustrated in Typical Performance Curves. This relationship is, of course, restricted to values of  $I_s$  between 1nA and 1mA and output voltages of less than  $\pm 10\text{V}$ .

### CHOOSING THE OPTIMUM SCALE FACTOR AND REFERENCE CURRENT

To minimize the effects of output offset and noise, it is usually best to use the full  $\pm 10\text{V}$  output range. Once an output range of  $\pm 10\text{V}$  has been chosen, then "A" and  $I_R$  can be determined from the Min/Max of the input current,  $I_s$ .

$$E_o = -A \log \frac{I_s}{I_R}, \text{ where } I_{\text{MIN}} < I_s < I_{\text{MAX}}$$

The output range of  $\pm 10\text{V}$  for an input range of  $I_{\text{MIN}}$  to  $I_{\text{MAX}}$  means that:

$$+10 = -A \log \frac{I_{\text{MIN}}}{I_R} \text{ and } -10 = -A \log \frac{I_{\text{MAX}}}{I_R}$$

Adding these two equations together

$$\log \frac{I_{\text{MAX}} + I_{\text{MIN}}}{I_R^2} = 0, \text{ or } I_R = \sqrt{I_{\text{MAX}} I_{\text{MIN}}}$$

The value for A can be found from:

$$10 = A \log \frac{I_{\text{MAX}}}{\sqrt{I_{\text{MAX}} I_{\text{MIN}}}}$$

In terms of the input current range for  $I_s$ , the values for  $I_R$  and A that will provide a full  $\pm 10\text{V}$  output swing are:

$$I_R = \sqrt{I_{\text{MAX}} I_{\text{MIN}}} \text{ and } A = \frac{10}{\log \frac{I_{\text{MAX}}}{I_R}}$$

#### EXAMPLE

Assume that  $I_{\text{MIN}}$  is +10nA and  $I_{\text{MAX}}$  is +100 $\mu\text{A}$ .

This is an 80dB range.

$$I_R = \sqrt{I_{\text{MAX}} I_{\text{MIN}}} = \sqrt{(10^{-4})(10^{-8})} = 10^{-6}, \text{ or } 1\mu\text{A}.$$

$$\frac{I_{\text{MAX}}}{I_R} = \frac{10^{-4}}{10^{-6}} = 100$$

$$\log \frac{I_{\text{MAX}}}{I_R} = 2; \text{ So, } A = 5$$

For an  $I_R$  of 1 $\mu\text{A}$  and A of 5,

$$E_o = -5 \log \frac{I_s}{1\mu\text{A}}$$

## CONNECTION DIAGRAMS

Transfer function is  $E_o = -A \log \frac{I_1}{I_R}$  where  $I_1$  is a positive

input current and  $I_R$  is the resistor-programmed internal reference current (see Figure 2).

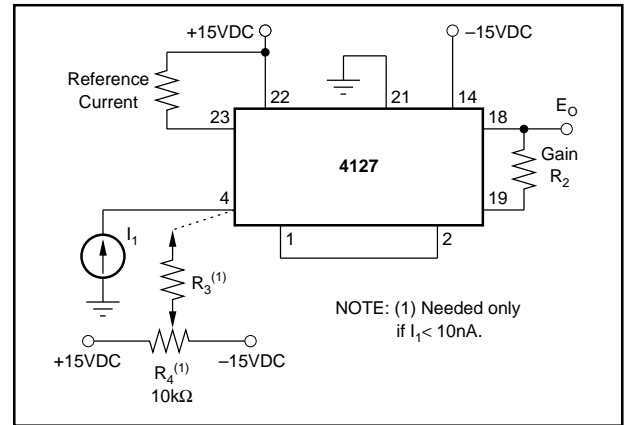

FIGURE 2. Transfer Function When  $I_1$  is Positive.

### ADJUSTMENT PROCEDURE

1. Refer to Choosing the Optimum Scale Factor and Reference Current.
2. Apply  $|I_1| = I_R$ , adjust  $R_1$  such that  $E_o = 0$ .
3. Apply  $|I_1| = I_{\text{MAX}}$ , adjust  $R_2$  for the proper output voltage.
4. Repeat steps 2 and 3 if necessary.
5. Ignore this step if  $|I_{\text{MIN}}| \geq 10\text{nA}$ . Otherwise, apply  $|I_1| = 1\text{nA}$ , make  $R_3 = 1\text{kM}\Omega$  and adjust  $R_4$  for the proper output voltage. For  $R_3$ , a single resistor is recommended. A voltage divider network is difficult to use due to amplifier offset voltage.

Transfer function is  $E_o = -A \log \frac{|I_1|}{I_R}$  where  $I_1$  is a negative

input current and  $I_R$  is the resistor-programmed internal reference current (see Figure 3).

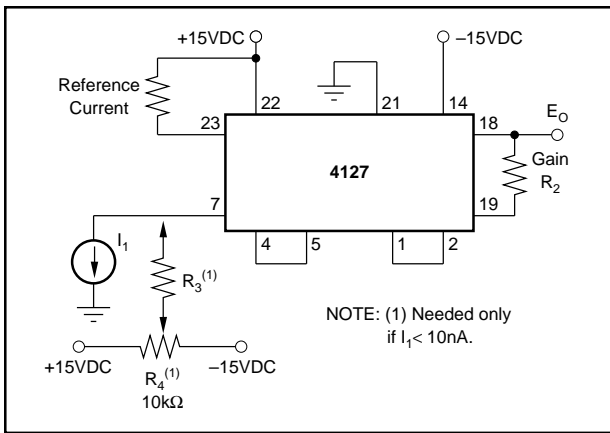

FIGURE 3. Transfer Function When  $I_1$  is Negative.

### ADJUSTMENT PROCEDURE

1. Refer to Choosing the Optimum Scale Factor and Reference Current.
2. Apply  $|I_1| = I_R$  adjust  $R_1$  such that  $E_o = 0$ .
3. Apply  $|I_1| = I_{MAX}$ , adjust  $R_2$  for the proper output voltage
4. Repeat steps 2 and 3 if necessary.
5. Ignore this step if  $|I_{1MIN}| \geq 10nA$ . Otherwise, apply  $|I_1| = 1nA$ , make  $R_3 = 1kM\Omega$  and adjust  $R_4$  for the proper output voltage. For  $R_3$ , a single resistor is recommended. A voltage divider network is difficult to use due to amplifier offset voltage.

Transfer function is  $E_o = -A \log \frac{E_1}{R_4 I_R}$ , where  $E_1$  is a positive input voltage and  $I_R$  is the resistor-programmed internal reference current (see Figure 4).

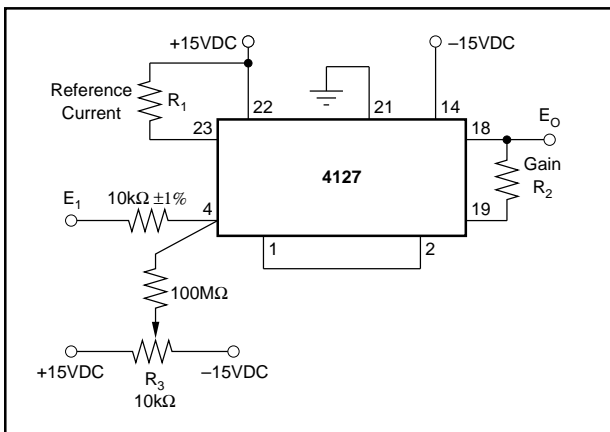

FIGURE 4. Transfer Function When  $E_1$  is Positive.

### ADJUSTMENT PROCEDURE

1. Refer to Choosing the Optimum Scale Factor and Reference Current.
2. Apply  $E_1 = I_R$  (10k $\Omega$ ), adjust  $R_1$  such that  $E_o = 0$ .
3. Apply  $E_1 = E_{MAX}$ , adjust  $R_2$  for the proper output voltage.

4. Apply  $E_1 = E_{MIN}$ , adjust  $R_3$  for the proper output.
5. Repeat steps 2 through 4 if necessary.

Transfer function is  $E_o = -A \log \frac{|E_1|}{R_4 I_R}$ , where  $E_1$  is a negative input voltage and  $I_R$  is the resistor-programmed internal reference current (see Figure 5).

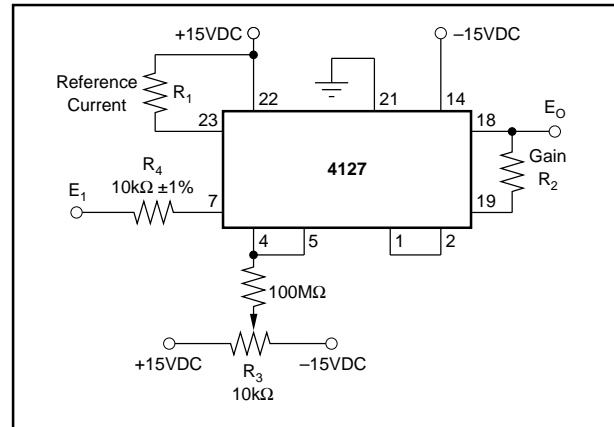

FIGURE 5. Transfer Function When  $E_1$  is Negative.

### ADJUSTMENT PROCEDURE

1. Refer to Choosing the Optimum Scale Factor and Reference Current.
2. Apply  $|E_1| = I_R$  (10k $\Omega$ ), adjust  $R_1$  such that  $E_o = 0$ .
3. Apply  $|E_1| = E_{MAX}$ , adjust  $R_2$  for the proper output voltage.
4. Apply  $|E_1| = E_{MIN}$ , adjust  $R_3$  for the proper output.
5. Repeat steps 2 through 4 if necessary.

Transfer function is  $E_o = -A \log \frac{|I_1|}{|I_2|}$  with  $I_1$  and  $I_2$  negative;  $|I_1| \geq 1nA$ ,  $|I_2| \geq 1\mu A$  (see Figure 6).

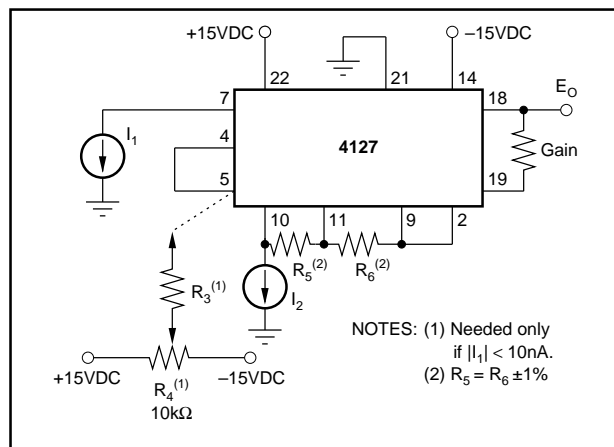

FIGURE 6. Transfer Function When  $I_1$  and  $I_2$  are Negative.

### ADJUSTMENT PROCEDURE

1. Refer to Choosing the Optimum Scale Factor and Reference Current.
2. No further adjustment is necessary if  $I_{1\text{ MIN}} \geq 10\text{nA}$ , otherwise connect the  $R_3$  and  $R_4$  network, with  $R_4 = 10\text{k}\Omega$  and  $R_3 = 10^9\Omega$ . Adjust  $R_4$  for proper output voltage after adjusting gain errors. Since the voltage at pin 4 is in the range of  $\pm 5\text{mV}$ , it is not practical to use a T-network to replace  $R_3$ .

Transfer function is  $E_o = -A \log \frac{|I_1|}{I_2}$  with  $I_1$  negative,  $I_2$  positive;  $|I_1| \geq 1\text{nA}$ ,  $I_2 \geq 1\mu\text{A}$  (see Figure 7).

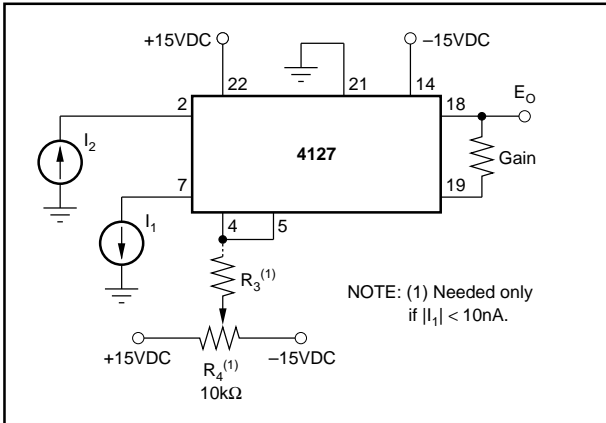

FIGURE 7. Transfer Function When  $I_1$  is Negative,  $I_2$  is Positive.

### ADJUSTMENT PROCEDURE

1. Refer to Choosing the Optimum Scale Factor and Reference Current.
2. No further adjustment is necessary if  $|I_1|_{\text{MIN}} \geq 10\text{nA}$ , otherwise connect the  $R_3$  and  $R_4$  network, with  $R_4 = 10\text{k}\Omega$  and  $R_3 = 10^9\Omega$ . Adjust  $R_4$  for proper output voltage after adjusting gain errors. Since the voltage at pin 4 is in the range of  $\pm 5\text{mV}$ , it is not practical to use a T-network to replace  $R_3$ .

Transfer function is  $E_o = -A \log \frac{I_1}{I_2}$  with  $I_1$  and  $I_2$  positive;  $I_1 \geq 1\text{nA}$ ,  $I_2 \geq 1\mu\text{A}$  (see Figure 8).

### ADJUSTMENT PROCEDURE

1. Refer to Choosing the Optimum Scale Factor and Reference Current.
2. No further adjustment is necessary if  $I_1\text{ MIN} \geq 10\text{nA}$ , otherwise connect the  $R_3$  and  $R_4$  network, with  $R_4 = 10\text{k}\Omega$  and  $R_3 = 10^9\Omega$ . Adjust  $R_4$  for proper output voltage after adjusting gain errors. Since the voltage at pin 4 is in the

range of  $\pm 5\text{mV}$ , it is not practical to use a T-network to replace  $R_3$ .

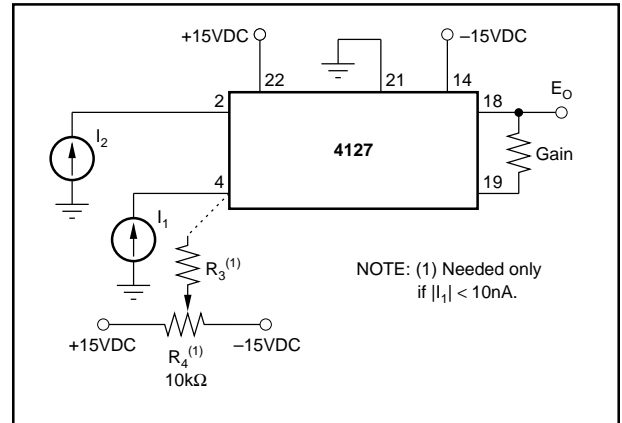

FIGURE 8. Transfer Function When  $I_1$  and  $I_2$  is Positive.

### ANTILOG OPERATION

The 4127 can also perform the antilog function. The output is connected through a resistor,  $R_o$ , into the current input, pin 4. The input signal is connected through a gain resistor to pin 19 as shown in Figure 9.

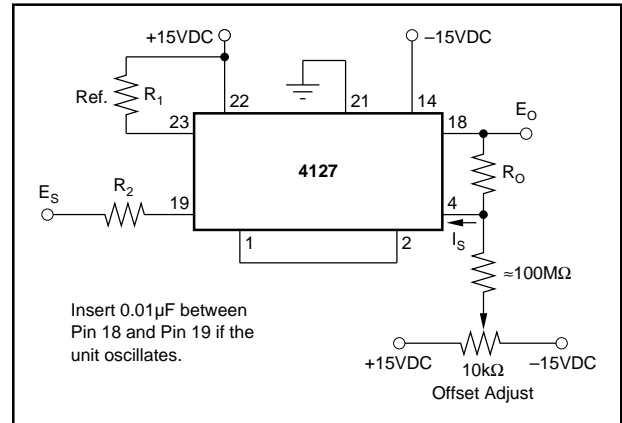

FIGURE 9. Antilog Operation.

These connections form an implicit loop for computing the antilog function. From the block diagram of Figure 1, the voltage at the inverting input of the output amplifier  $A_2$  must equal  $E_2$ , so

$$E_2 \approx \frac{R_T}{R_T + R_2} E_s, R_T \approx 520\Omega$$

Since the output is connected through  $R_o$  to pin 4, the current  $I_s$  will equal  $E_o/R_o$  and  $E_2$  will be

$$E_2 = -\frac{mKT}{q} \ln \frac{E_o}{R_o I_R}$$

Combining expressions for  $E_2$  gives the relationship:

$$\frac{R_T}{R_T + R_2} E_S = - \frac{mKT}{q} \ell n \frac{E_O}{R_O I_R}$$

$$- \frac{E_S}{A} = \log \frac{E_O}{R_O I_R}$$

where:

$$A \approx \frac{R_T + R_2}{R_T} (26\text{mV}) \frac{1}{0.434}$$

$$E_O = R_O I_R \text{ Antilog} - \frac{E_S}{A}$$

Setting  $R_O$  and  $I_R$  will set the scale factor. For example, an  $R_O$  of  $1\text{M}\Omega$  and  $I_R$  of  $1\mu\text{A}$  will give a scale factor of unity

and  $E_O = \text{Antilog} - \frac{E_S}{A}$



## **IMPORTANT NOTICE**

Texas Instruments and its subsidiaries (TI) reserve the right to make changes to their products or to discontinue any product or service without notice, and advise customers to obtain the latest version of relevant information to verify, before placing orders, that information being relied on is current and complete. All products are sold subject to the terms and conditions of sale supplied at the time of order acknowledgment, including those pertaining to warranty, patent infringement, and limitation of liability.

TI warrants performance of its semiconductor products to the specifications applicable at the time of sale in accordance with TI's standard warranty. Testing and other quality control techniques are utilized to the extent TI deems necessary to support this warranty. Specific testing of all parameters of each device is not necessarily performed, except those mandated by government requirements.

Customers are responsible for their applications using TI components.

In order to minimize risks associated with the customer's applications, adequate design and operating safeguards must be provided by the customer to minimize inherent or procedural hazards.

TI assumes no liability for applications assistance or customer product design. TI does not warrant or represent that any license, either express or implied, is granted under any patent right, copyright, mask work right, or other intellectual property right of TI covering or relating to any combination, machine, or process in which such semiconductor products or services might be or are used. TI's publication of information regarding any third party's products or services does not constitute TI's approval, warranty or endorsement thereof.