



# ELM412 Piezo Element Driver

## Description

The ELM412 is an 8 pin oscillator circuit for driving piezo-electric elements. With the exception of one external resistor, all of the circuitry required to drive a typical piezo ‘bender’ is contained within this chip.

This circuit allows the user to select one of eight possible operating frequencies by way of three logic level inputs. These eight frequencies represent some of the more common resonant frequencies used for piezo elements. If desired, the frequency can be continually varied by the controlling circuit.

The output of the ELM412 uses a bridge configuration to obtain maximum audio drive for a given power supply level. A single input pin is all that is required to gate the output on and off.

Typically the ELM412 is used to relieve a processor of the duty of waveform generation, allowing it to concentrate on other activities, although the circuit can also be used in stand-alone tone generator circuits.

## Features

- Low power CMOS design
- Wide supply range - 3.0 to 5.5 volt operation
- No external timing elements required
- Generates eight common piezo frequencies
- Bridged output for greater audio power
- Modified waveform for reduced harmonics

## Applications

- Computer controlled tone generation
- Alarm warning signals
- Keyboard click generation
- Logic probe circuits

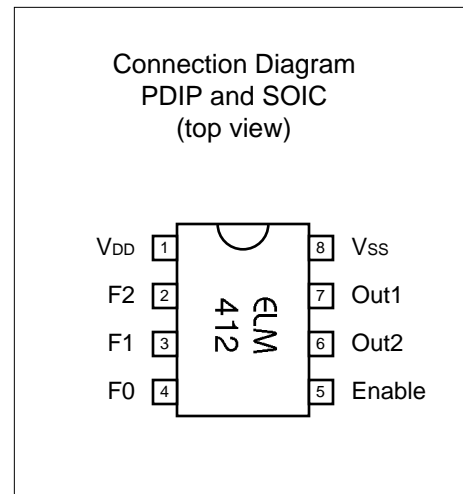

## Block Diagram

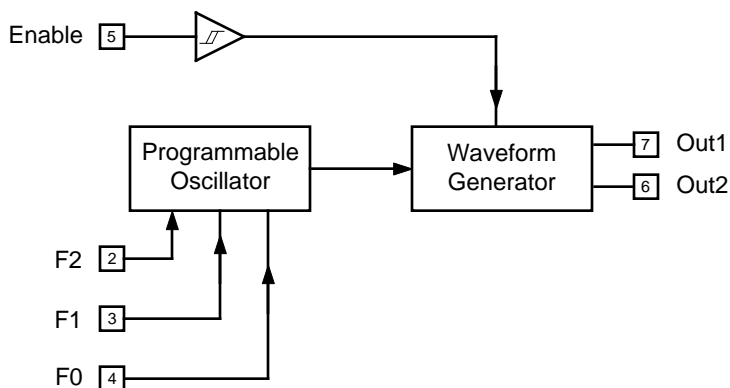

F2	F1	F0	Frequency
L	L	L	600
L	L	H	1200
L	H	L	2000
L	H	H	2400
H	L	L	2800
H	L	H	3200
H	H	L	3600
H	H	H	4000

Table 1



**Pin Descriptions**

V<sub>DD</sub> (pin 1)

This pin is the positive supply pin, and should always be the most positive point in the circuit. Internal circuitry connected to this pin is used to provide power on reset of the microprocessor, so an external reset signal is not required. Refer to the Electrical Characteristics section for further information.

F2 (pin 2), F1 (pin 3) and F0 (pin 4)

These are the frequency select inputs. One of eight frequencies are selected according to the logic levels on these pins, as shown in Table 1.

Enable (pin 5)

This schmitt trigger input pin is used to control the output. A high level at this input will allow the outputs to appear at pins 6 and 7, while a low level inhibits the output. The schmitt trigger input

is convenient for interfacing to slowly changing signals, as from an RC coupled circuit.

Out2 (pin 6) and Out1 (pin 7)

These complementary outputs are used to drive the piezo-electric element through a current limiting resistor. The outputs switch between V<sub>DD</sub> and V<sub>SS</sub> with a combined duty cycle of approximately 67% (see Figure 2). This results in reduced harmonics in the output signal and more energy to the fundamental. The output always consists of complete cycles, as the cycle that is in progress when the enable input goes low will always be allowed to complete.

V<sub>SS</sub> (pin 8)

Circuit common is connected to this pin. This is the most negative point in the circuit.

**Ordering Information**

These integrated circuits are available in either the 300 mil plastic DIP format, or in the 200 mil SOIC surface mount type of package. To order, add the appropriate suffix to the part number:

300 mil Plastic DIP..... ELM412P

200 mil SOIC..... ELM412SM

**Absolute Maximum Ratings**

Storage Temperature..... -65°C to +150°C

Ambient Temperature with Power Applied..... -40°C to +85°C

Voltage on V<sub>DD</sub> with respect to V<sub>SS</sub>..... 0 to +7.5V

Voltage on any other pin with respect to V<sub>SS</sub>..... -0.6V to (V<sub>DD</sub> + 0.6V)

Note:

Stresses beyond those listed here will likely damage the device. These values are given as a design guideline only. The ability to operate to these levels is neither inferred nor recommended.

All rights reserved. Copyright ©1999 Elm Electronics.

Every effort is made to verify the accuracy of information provided in this document, but no representation or warranty can be given and no liability assumed by Elm Electronics with respect to the accuracy and/or use of any products or information described in this document. Elm Electronics will not be responsible for any patent infringements arising from the use of these products or information, and does not authorize or warrant the use of any Elm Electronics product in life support devices and/or systems. Elm Electronics reserves the right to make changes to the device(s) described in this document in order to improve reliability, function, or design.



## Electrical Characteristics

All values are for operation at 25°C and a 5V supply, unless otherwise noted. For further information, refer to note 1 below.

Characteristic	Minimum	Typical	Maximum	Units	Conditions
Supply Voltage, $V_{DD}$	3.0	5.0	5.5	V	
$V_{DD}$ rate of rise	0.05			V/ms	see note 2
Average Supply Current, $I_{DD}$		1.0	2.4	mA	$V_{DD} = 5V$ , see note 3
		0.60	2.4	mA	$V_{DD} = 3V$ , see note 3
Input low voltage	$V_{SS}$		$0.15 V_{DD}$	V	
Input high voltage	$0.85 V_{DD}$		$V_{DD}$	V	
Output low voltage			0.6	V	Current (sink) = 8.7mA
Output high voltage	$V_{DD} - 0.7$			V	Current (source) = 5.4mA
Output Duty Cycle		67		%	
Output series resistance	470	2200			see note 4
Frequency Accuracy		2		%	see note 5

- Notes:
1. This integrated circuit is produced with a Microchip Technology Inc.'s PIC12C5XX as the core embedded microcontroller. For further device specifications, and possibly clarification of those given, please refer to the appropriate Microchip documentation.
  2. This spec must be met in order to ensure that a correct power on reset occurs. It is quite easily achieved using most common types of supplies, but may be violated if one uses a slowly varying supply voltage, as may be obtained through direct connection to solar cells, or some charge pump circuits.
  3. Internal IC current only. Does not include any piezo or other currents.
  4. A series resistor must be used to limit the current peaks due to the relatively large capacitance (~50nF) of a piezo element. Maximum size is determined by the desired volume level.
  5. Frequency error is both supply and temperature dependent, typically as shown in Figure 1 below.

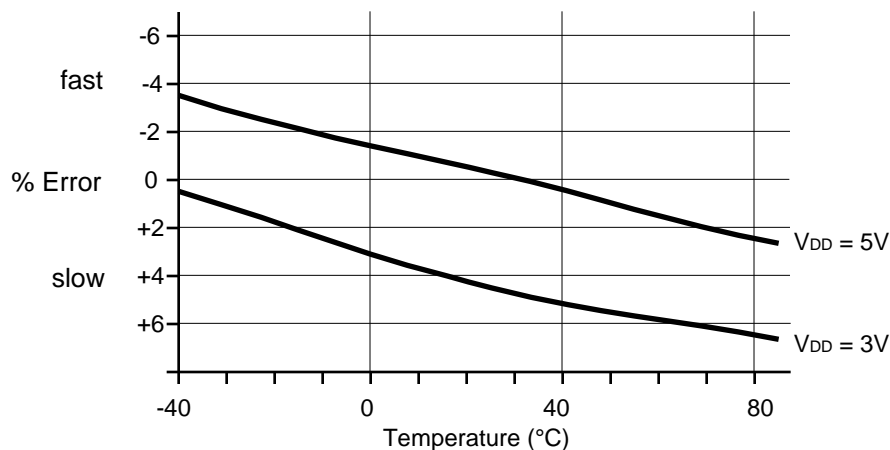

Figure 1. Average Frequency Error

## Output Waveforms

The output waveforms are generated as long as the enable input remains high. When brought low, the current cycle completes before the output ceases.

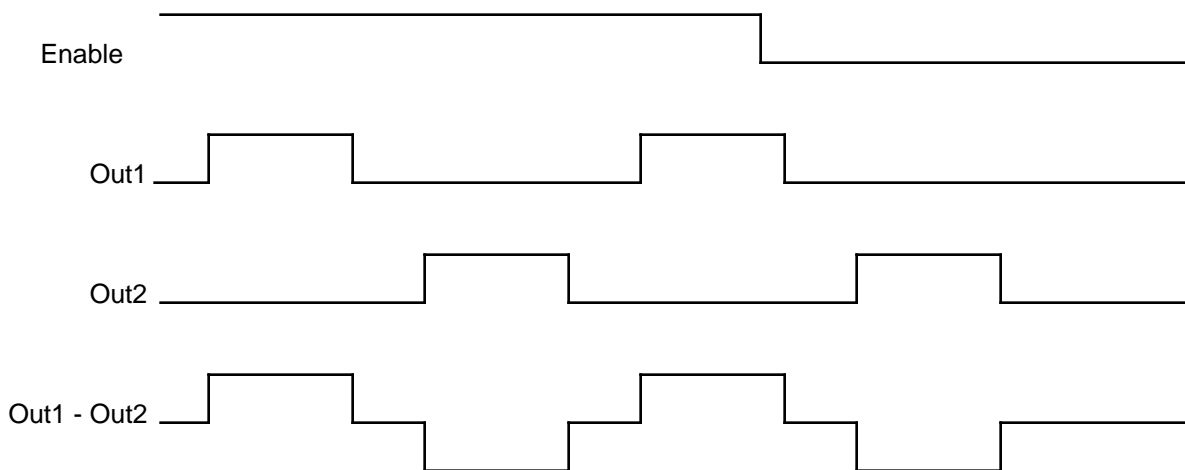

Figure 2.

## Example Application

Operation of the ELM412 is straightforward, requiring little explanation. Typically the resonant frequency of the piezo element is determined, and pins 2, 3 and 4 are connected for this frequency. In the circuit of Figure 3, the frequency has been set for 2400Hz. A single bit from a control circuit is then used to turn the buzzer on and off.

The 2.2K resistor shown in the circuit serves two purposes. One is to provide a current limit for the ELM412 as it tries to rapidly change the piezo voltage (the piezo is like a large capacitor), and the other is to simply limit the output loudness.

The only other detail in Figure 3 is the customary 0.01µF capacitor for supply decoupling. It's always good practice to add one, although it's often not essential.

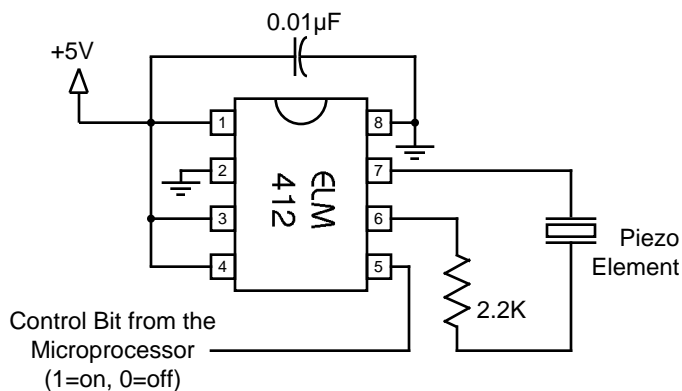

Figure 3.