

# **Service Manual**

**CB TRANSCEIVER**

**Model JACKSON**

**UT-547C/D**

**uniden<sup>®</sup>**  
**CORPORATION**

# TABLE OF CONTENTS

- A. SPECIFICATIONS
- B. INSTALLATION
- C. GENERAL INFORMATION
- D. OPERATING CONTROLS
- E. ALIGNMENT PROCEDURES
- F. FREQUENCIES
- G. BLOCK DIAGRAM
- H. SCHEMATIC DIAGRAMS/WIRING DIAGRAM/PC BOARD
  - 1. E12-2108 : SCHEMATIC DIAGRAM
  - 2. E12-2108 : REVISED
  - 3. E22-4674 : MAIN PCB PARTS ASSEMBLY TOP VIEW
  - 4. E32-2212 : WIRING DIAGRAM
- I. BILL OF MATERIAL : 25 P.S

## A. SPECIFICATIONS

### 1. GENERAL

Channel and Frequency Range	:	226 A Band 26.065 - 26.505 MHz B Band 26.515 - 26.955 MHz C Band 26.965 - 27.405 MHz D Band 27.415 - 27.855 MHz E Band 27.865 - 28.315 MHz
Crystals	:	3
Microphone	:	600 ohms, Dynamic Type
Speaker	:	8 ohms, 3 W
Antenna Connector	:	M Type
Jacks & Connectors	:	Mic 4P EXT. SP -3.5 $\phi$ PA. SP -3.5 $\phi$ DC Power -3P
Controls	:	Channel Selector, Mode Selector FM-AM-USB-LSB, Mic Gain, ON/OFF Power Switch & Volume, ON/OFF PA Switch & Squelch, RF Gain, Coarse, Fine, Band Selector A-B-C-D-E, Noise Blanker/ ANL Switch, Roger Beep Switch, S/RF-Mod Switch and +10 kHz - Normal Switch
Meter	:	RF Output Power, Signal Strength and Modulation
Illumination	:	Channel Number Indication (LED) RX, TX Indication (LED), Meter Lamp
Size	:	7.784"(W) X 2.36"(H) X 11.22"(D)
Weight	:	5 Pounds (2.2 kgs)
Accessories	:	DC Power Cable with Built-in Fuse, Microphone and Microphone Hanger

### 2. MEASUREMENT CONDITIONS

a) Power Source	:	13.8 V (DC)
b) Antenna Impedance	:	50 ohms
c) Test Temperature	:	25 $\frac{1}{2}$ C
d) AM Modulation Frequency	:	1 kHz
e) FM Modulation Frequency	:	1 kHz
f) SSB Modulation Frequency, Two Tone	:	500 Hz & 2.400 Hz
g) Mean Signal Input Level	:	1.000 uV
h) Reference AM Modulation Percentage	:	1 kHz 30%

- i) Reference FM Deviation : 1.5 kHz
- j) Reference Audio Output Power : 0.5 W
- k) Audio Frequency : 1 kHz
- l) Audio Output Load : 8 ohms Resistive

3. TRANSMITTER	UNIT	NOMINAL	LIMIT	
a) Frequency Tolerance at 25 ½ (5 Minutes after Switch on)	AM Hz	± 300	± 1.500	
	SSB Hz	± 300	± 1.500	
	FM Hz	± 300	± 1.500	
b) Carrier Power	AM W	10.0	8.0 - 14.0	
	FM W	10.0	8.0 - 14.0	
c) PRP Power, Two Tone, SSB	Wpwp	21.0	18.0 - 26.0	
d) Spurious & Harmonic Emission	AM dB	-50	-40	
	SSB dB	-50	-40	
	FM dB	-50	-40	
e) Carrier Suppression	SSB dB	-55	-40	
f) Unwanted Sideband Suppression (at 2.500 Hz 4 Wpwp 16 dB Single tone)	SSB dB	-50	-40	
g) Battery Drain at no Modulation	AM mA	3.000	4.500	
	SSB mA	800	1.500	
	FM mA	3.000	4.500	
h) Battery Drain Am : MAX Modulation SSB: MAX Wpwp, Two Tone FM : MAX Modulation	mA	3.000	4.500	
	mA	3.000	4.500	
	mA	3.000	4.500	
i) Modulation Frequency Response (1 kHz, 0dB reference)	Lower at 450 Hz	AM dB	-4	-10
		SSB dB	-4	-10
		FM dB	-4	-10
	Lower at 2.5 kHz	AM dB	-4	-10
		SSB dB	-4	-10
		FM dB	-4	-10
j) Microphone Sensitivity AM : For 50% Modulation SSB: For 10 Wpwp Output FM : For 1 kHz Deviation	mV	1.0	2.0	
	mV	1.0	2.0	
	mV	1.0	2.0	
k) AMC Range AM : 50 - 100% Modulation SSB:	dB	50	40	
	dB	50	40	

<u>4. RECEIVER (ANL/NB Switch off)</u>	<u>UNIT</u>	<u>NOMINAL</u>	<u>LIMIT</u>
a) Max Sensitivity	AM uV	0.5	2.0
	SSB uV	0.25	1.0
b) Sensitivity for 10dB S/N	AM uV	0.5	2.0
	SSB uV	0.25	1.0
	FM : 20dB S/N FM uV	0.5	3.0
c) AGC Figure of Merit, 50 mV for 10dB change in Audio Output	AM dB	80	70
	SSB dB	80	70
d) Overall Audio Fidelity at 6dB down	Upper Frequency		
	AM Hz	2.000	1.500 - 3.000
	SSB Hz	3.000	2.000 - 4.500
	FM Hz	2.500	1.500 - 4.000
	Lower Frequency		
	AM Hz	300	100 - 500
	SSB Hz	300	100 - 500
	FM Hz	300	100 - 500
e) Adjacent Channel Selectivity (10 kHz 1 GEN)	AM dB	70	60
f) Maximum Audio Output Power	AM W	4.0	3.0
	SSB W	4.0	3.0
	FM W	4.0	3.0
g) Audio Output Power at 10% THD	AM W	2.5	2.0
	SSB W	2.5	2.0
	FM W	2.5	2.0
h) RF Gain Control Range	AM dB	55	30 - 70
	SSB dB	55	30 - 70
	FM dB	55	30 - 70
i) S/N Ratio at 1mV Input	AM dB	30	25
	FM dB	35	25
j) Squelch Sensitivity at Threshold	AM uV	0.5	2.0
	SSB uV	0.5	2.0
	FM uV	0.5	2.0
k) Squelch Sensitivity at Tight	AM uV	1.000	250 - 4.000
	SSB uV	1.000	250 - 4.000
	FM uV	1.000	250 - 4.000
l) S Meter Sensitivity at "S-9" (No Modulation)	AM uV	100	25 - 400
	SSB uV	100	25 - 400
	FM uV	100	25 - 400
m) Image Rejection Ratio	AM dB	65	50
	SSB dB	65	50
	FM dB	65	50
n) IF Rejection Ratio	AM dB	85	70
	SSB dB	85	70
	FM dB	85	70
o) Oscillator Dropout Voltage	AM V	9	11
	SSB V	9	11
	FM V	9	11

	<u>UNIT</u>	<u>NOMINAL</u>	<u>LIMIT</u>
p) Battery Drain at No Signal	AM mA	500	800
	SSB mB	500	800
	FM mA	500	800
q) Battery Drain at Max. Audio Output	AM mA	1.000	1.500
	SSB mA	1.000	1.500
	FM mA	1.000	1.500
r) Clarifier Range	AM kHz	± 7.0	More than ± 5.0
	SSB kHz	± 7.0	More than ± 5.0
	FM kHz	± 7.0	More than ± 5.0
<b>5. <u>PUBLIC ADDRESS</u></b>			
a) Output Power at 10% Distortion	W	2.5	2

**NOTE :**

- 1) Shall have reverse polarity protection and operable with positive or negative grounding
- 2) Operating Power Voltage : 13.8V + 15 - 20% DC

## **B. INSTALLATION**

### **1. LOCATION**

Plan the location of the transceiver and microphone bracket before starting the installation. Select a location that is convenient for operation and does not interfere with the driver or passenger in the vehicle. In automobiles, the transceiver is usually mounted to the dash panel with the microphone bracket beside it.

### **2. MOUNTING AND CONNECTION**

This radio is supplied with a universal mounting bracket. The transceiver is held in the bracket by the four thumb screws supplied, permitting adjustment to the most convenient angle. The bracket must be mounted with the screws supplied. The mounting surface must be mechanically strong. Proceed as follows to mount the transceiver :

- a) After you have determined the most convenient location in your vehicle, hold the radio with the mounting bracket in the exact location desired. If nothing interferes with mounting it in the desired position, remove the mounting bracket thumb screws and mark the mounting holes using the bracket as a template. Before drilling the holes, make sure nothing will interfere with the installation of the mounting screws. Drill the holes and mount the bracket and then install the radio.
- b) Connect the antenna cable plug to the standard receptacle on the rear panel. Most CB antennas are terminated with a type PL-259 plug which mates with the receptacle on the rear panel.
- c) Connect the DC power input wire with the fuse (red) to +12V DC. This wire extends from a plug which connects to the rear panel. In automobile installations, +12V DC is usually obtained from the accessory contact on the ignition switch. This prevents the set being left on accidentally when the driver leaves the car and also permits operating the radio without the engine running. You can locate the

accessory contact on most ignition switches by tracing the power wire from the AM broadcast receiver in the car.

- d) Connect the black wire to ground. This is usually the chassis of the car. Any convenient location with good electrical contact may be used. (remove paint).

Note : See ground connection under GENERAL INFORMATION for more detail.

- e) Mount the microphone hanger on the side of the unit or near the unit, using the screws supplied.



## C. GENERAL INFORMATION

### 1. GROUND CONNECTION

This radio may be installed and used in any 12V DC negative or positive ground system vehicle.

- a) Negative ground system : Connect the Red power lead from the radio to the positive or (+) battery terminal or other convenient point, and connect the Black power lead to the chassis or vehicle frame or (-) battery terminal.
- b) Positive ground system : In the cases of positive ground system, connect the Black power lead from the radio to the negative or (-) battery terminal or other convenient point, and connect the Red power lead to the chassis or vehicle frame or (+) battery terminal.

### 2. ANTENNA

This radio is designed to operate into a 50 ohm CITIZENS RADIO antenna. Best result will be obtained from your transceiver if you use good antenna and properly install your antenna. (Refer to the antenna installation instructions included with your antenna.)

A vertically polarized quarter-wavelength whip antenna provides the most reliable operation and greater range. The shorter loaded-type whip antennas are more attractive, compact and adequate for applications where the maximum possible distance is not required. Also, the loaded whip antennas do not present the problems of height imposed by the full quarter-wavelength whip.

When installed in a boat, the transceiver will operate most efficiently when the antenna used has been especially designed for marine applications.

Mobile whip antennas utilize the metal body of the vehicle as a ground plane. When mounted on a corner of the vehicle, they are slightly directional, in the direction of the body of the vehicle. For all practical purposes, however, the radiation pattern is non-directional. A slight directional characteristic will be observed only at extreme distances. A standard antenna connector (Type

SO-239) is provided on the transceiver for easy connection to a standard PL-259 cable termination.

Before installing the transceiver in a boat, consult your dealer for information regarding an adequate grounding system and prevention of electrolysis between fittings in the hull and water.

### 3. BASE STATION OPERATION

To operate the transceiver from your home or office, using regular house current as the power source, you will require a separate power supply capable of supplying 5 amps at a 13.8V DC output with a nominal input voltage of 220 volts AC, 50/60 Hz.

Simply connect the red (+) and black (-) leads to the transceiver to the corresponding DC terminals of the power supply.

**NOTE** : Do not attempt to operate this transceiver by connecting directly to 220V AC. When an AC power supply is used with the transceiver for base station operation any Citizens Band beam, dipole, ground plane or vertical antenna may be used. A ground plane vertical antenna will provide the most uniform horizontal coverage.

### 4. REMOTE SPEAKER

The external speaker jack (EXT. SPKR) on the rear panel is used for remote receiver monitoring. The external speaker should have 8 ohms impedance. When the external speaker is plugged in, the internal speaker is disconnected.

### 5. PUBLIC ADDRESS

An external 8 ohm 4-watt speaker must be connected to the (PA SPKR) jack located on the rear panel when the transceiver is used as a public address system. The speaker should be directed away from the microphone to prevent acoustic feedback. Physical separation or isolation of the microphone and speaker is important when operating the PA at high output levels.

### 6. OPERATING INSTRUCTIONS

The JACKSON operates on 226 AM/FM channels, 226 Upper Side Band channels and 226 Lower Side Band channels.

When you receive the SSB signal in the proper mode (USB or LSB),

audio sound may be either too high pitched or low pitched, indicating that your receiver may not be tuned to the exact same frequency as the transmitter to which it is listening. The JACKSON is equipped with a Clarifier. By tuning the Clarifier, you can slightly change the frequency of the receiver, so you get a normal tone.

#### D. OPERATING CONTROLS

Your JACKSON, designed for ease of operation, is provided with the following operating controls :

1. OFF/ON VOLUME : To turn the transceiver on, rotate the control clockwise past click. To turn the transceiver off, rotate the control counterclockwise past click. Rotate the control clockwise for a comfortable audio level.
2. SQUELCH : The squelch control is normally set to a position which eliminates undesired background noise with no signal present. With the audio adjusted to a satisfactory level, rotate the squelch control clockwise to the point where the sound from the speaker is cut off. In this position, there will be no sound from the speaker until a signal is received. In order to hear weak signals, it may be necessary to rotate the squelch control counterclockwise, allowing some background noise to be heard.
3. P.A. SWITCH (on SQUELCH) CONTROL : Full counterclockwise rotation of the squelch control engages the PA function. The PA function should not be used unless an external speaker is connected. In the squelch (or CB) position, the PA function is disabled and the radio will transmit and receive on the selected channel.
4. MODE SELECTION : This switch selects AM, FM, USB, or LSB mode of operation. This selector changes the mode of operation of both transmitter and receiver simultaneously. Set the selector to the mode on which you wish to communicate.
5. MIKE GAIN : This control is used to adjust, as required, microphone input sensitivity for optimum amount of modulation in transmit. President Electronics citizen's band transceivers have been designed to permit the user to attain levels of modulation up to 100 % depending on the setting of the microphone gain control, using the microphone provided with the unit. President's automatic compression and peak limiting circuits assure maximum modulation with minimum distortion.

6. **RF GAIN** : This control is used primarily to optimize reception in strong signal areas. Gain is reduced by counterclockwise rotation of the control.
7. **CLARIFIER** : The clarifier control is normally set to the center position. This feature has several uses and can greatly enhance receiver operation. First, if a received signal is slightly off frequency, this control can be operated as required to optimize the receiver frequency. The effectiveness of this clarifier feature under these conditions can be observed either by listening for a more readable signal at the speaker or by noting the S-meter reading when the clarifier control is operated. Another effective application of this control is in eliminating adjacent channel interference from strong signals. Operate this control, as required, to obtain minimum adjacent channel interference.
8. **METER MODE SWITCH** :
 

S/RF Position : Meter indicates relative transmitter output power when transmitting, input signal strength when receiving.

MOD Position : Meter indicates average percentage of modulation.
9. **NB/ANL SWITCH** : When switch is placed in NB/ANL position, the Automatic Noise Limiter and the RF Noise Blanker are activated simultaneously.
10. **+ 10KHZ FREQUENCY SHIFT SWITCH** : When switch is placed in + 10KHz position, frequency is shifted 10KHz up. On following channels, a channel can be used by setting this switch to + 10KHz position.

<u>Normal</u>	<u>+ 10 KHz</u>
3	3A
7	7A
11	11A
15	15A
19	19A

11. **BAND SWITCH** : This switch is used to select the band of frequency.
12. **CHANNEL SELECTOR** : This switch is used to select any one of the 40 Citizens Band channels. Channel 9 has been reserved for emergency communications involving immediate safety of life of individuals or

immediate protection of property.

13. ROGER BEEP SWITCH : When this switch is placed in the ROGER BEEP position, your radio automatically transmits the audio sign at the end of your transmission. The listener can easily note your transmission is over through the sign.

## E. ALIGNMENT PROCEDURES

### 1. ALIGNMENT OF PLL & CARRIER OSCILLATOR PORTION

#### a) Test Equipment Required

- Oscilloscope
- DC Power Supply (13.8V)
- Frequency Counter (0 - 50MHz)
- DC Voltmeter

#### b) Alignment Procedure

STEP	PRESET TO	ADJUSTMENT	REMARKS
1	Channel : 40 Mode : AM, RX. Clari : Center Band : E PA/CB : CB	L12	Connect DC Voltmeter to TP-2 (R122). Adjust for 6.0V $\pm$ 0.1V on DC Voltmeter. Confirm 2V to A Band Channel 1.
2	Same as above except BAND : C Channel : 19 Mode : AM.FM, RX	L13	Connect Oscilloscope to TP-3 (R73). Adjust for maximum reading on Oscilloscope.
3	Same as above	L14	Connect Frequency Counter to TP-3 (R73). Adjust for 16.490MHz $\pm$ 20Hz on the Frequency Counter.
4	Same as Step 2 except Mode : USB, RX	L15	Connect Frequency Counter to TP-3 (R73). Adjust for 16.4925MHz $\pm$ 20Hz on the Frequency Counter.
5	Same as Step 4 except Mode : LSB, RX	L16	Connect Frequency Counter to TP-3 (R73). Adjust for 16.4875MHz $\pm$ 20Hz on the Frequency Counter.
6	Same as above	L24	Connect Frequency counter to TP-4 (R104). Adjust for 10.6975MHz $\pm$ 20Hz on the Frequency Counter.

STEP	PRESET TO	ADJUSTMENT	REMARKS
7	Same as Step 4	L23	Connect Frequency counter to TP-4 (R104). Adjust for 10.6925MHz $\pm$ 20Hz on the Frequency counter.
8	Same as Step 4 except Mode : AM, TX	L22	Connect Frequency counter to TP-5 (R82). Adjust for 10.695MHz $\pm$ 20Hz on the Frequency counter.

c) Test Equipment Connection (see following page)



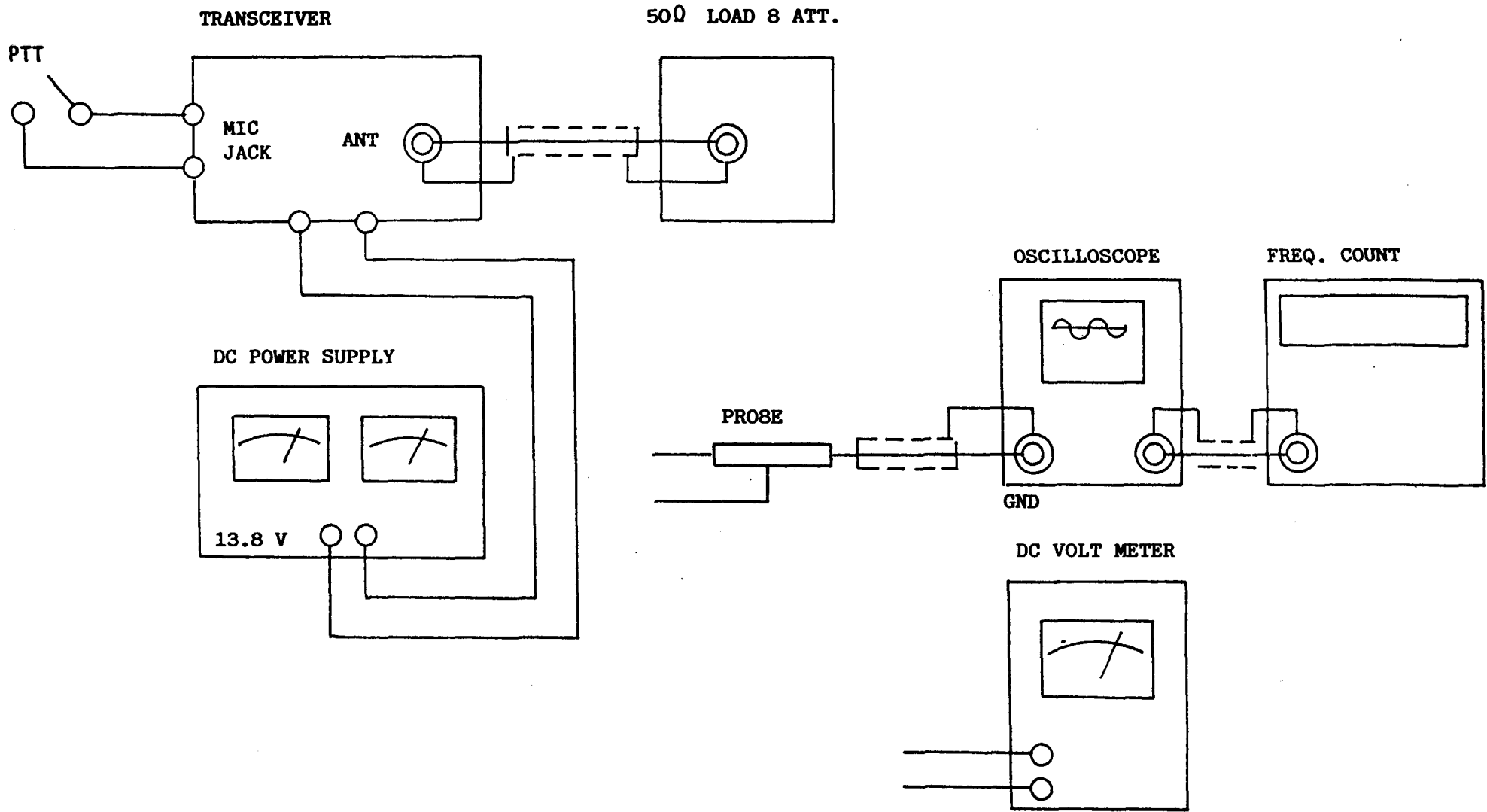

ALIGNMENT POINTS

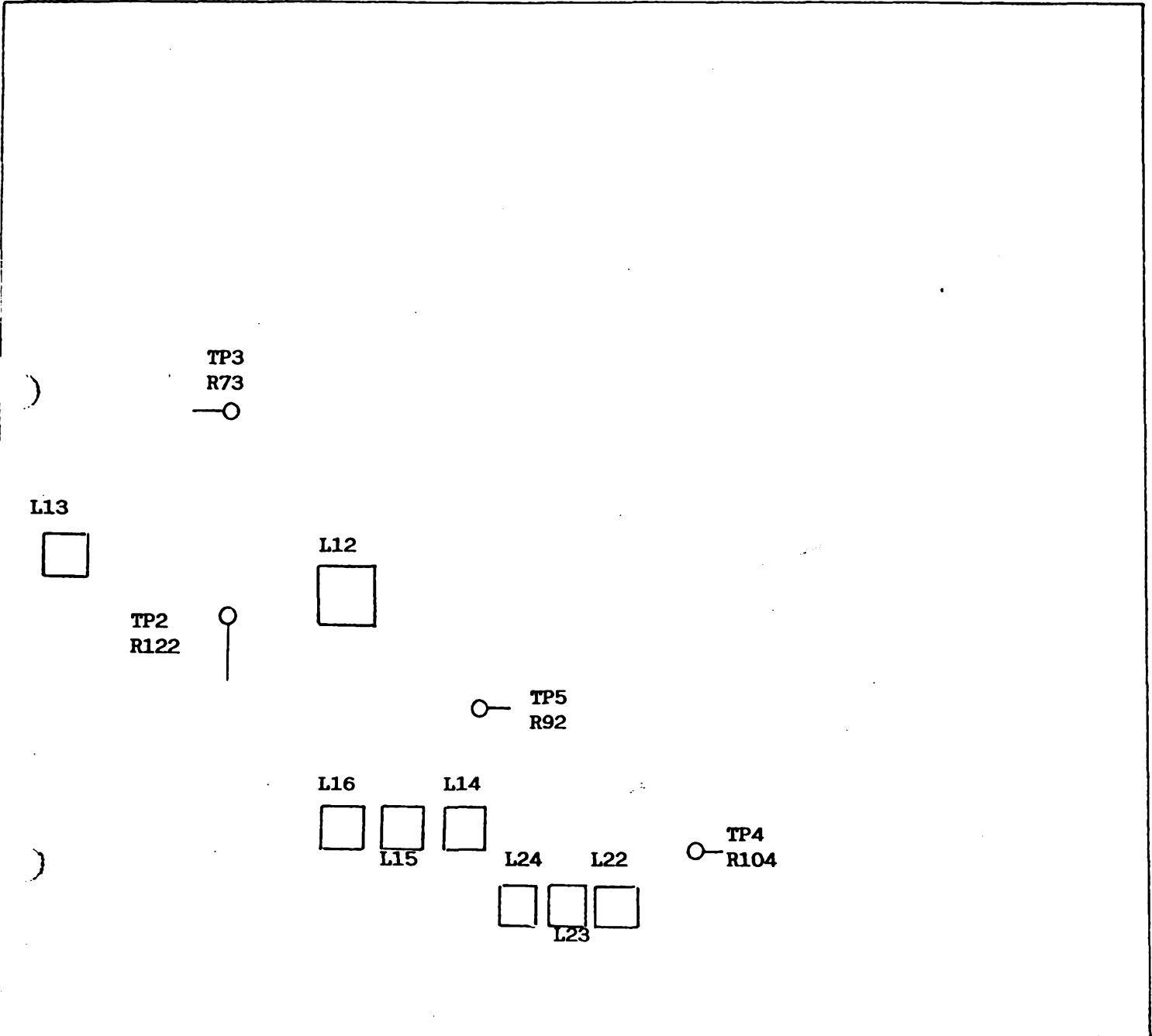

## 2. ALIGNMENT OF TRANSMITTER PORTION

### a) Test Equipment Required

- AF Signal Generator (1) for 500Hz and 1.000Hz
- AF Signal Generator (2) for 2.400Hz
- AF VTVM (150mV full scale)
- RF VTVM (50V full scale)
- RF Powermeter (10W Max. Thruline type)
- 50 ohm Dummy Load
- Oscilloscope
- Harmonic Meter
- DC Voltmeter
- DC Ammeter (150mA full scale)

### b) Alignment Procedure

STEP	PRESET TO	ADJUSTMENT	REMARKS
1	Channel : 19 Band : C Mode : USB, TX. No Modulation MIC GAIN : CW PA/CB : CB	VR10	Disconnect the PC-834AA from Check Point of Main P.C.Board and connect DC Ammeter to TP-8(+), TP-6(-). Adjust for 50mA on DC Ammeter.
2	Same as Step 1	VR9	Connect DC Ammeter to TP-8(+), TP-7(-). Adjust VR9 to obtain the current 80mA.
3	Mode : USB	L42	Disconnect the DC Ammeter. Connect PC-834AA to Check Point of Main P.C.Board. Connect power meter, RF VTVM and Oscilloscope. Set VR8 CW maximum. Turn the Cor of L42 CW maximum at the bottom.
4	Same as above	L41,43,49	Adjust coils for the maximum indication. While then, keep output voltage under 25V by adjusting SG.
5	Same as above	L42	Set E Band Channel 40, adjust for maximum reading and then set A Band Channel 1, adjust for minimum difference from E Band Channel 40.
6	Channel : 19 Band : E Mode : USB 2 Tone AF SG : 30mV	L30	Adjust L30 to obtain the maximum indication on the RF VTVM.

STEP	PRESET TO	ADJUSTMENT	REMARKS
7	same as above	VR8	Adjust VR3 to obtain RF output of 32.4V on the RF VTVM.
8	Same as Step 1	VR5	Adjust VR5 to obtain the minimum carrier leakage between USB and LSB.
9	Mode : AM, TX. No Modulation Channel : 19 Band : E	VR11	Adjust VR11 to obtain RF carrier power of 10W on RF Power meter.
10	Same as above except Push SW : S/RF	VR7	Adjust for the needle of Built-in Meter to blank zone of TX Power Meter.
11	Same as above except AF SG : 30mV 1KHz Mod.	VR12	Adjust VR12 to obtain 90% (negative) modulation.
12	Same as above except mode : FM	VR4	Connect Deviation meter. Adjust for 3kHz Deviation on Deviation meter.
13	Channel : 19 Band : C Push SW : MOD	VR3	Set AF SG to 50% Modulation, then add 16dB. Adjust VR3 to 100% modulation indication on the transceiver meter.
14	Channel : 19 Band : C No Modulation Mode : AM	VR6	Adjust Transmitter Frequency for 27.185MHz $\pm$ 100Hz.

c) Test Equipment Connection (see following page)

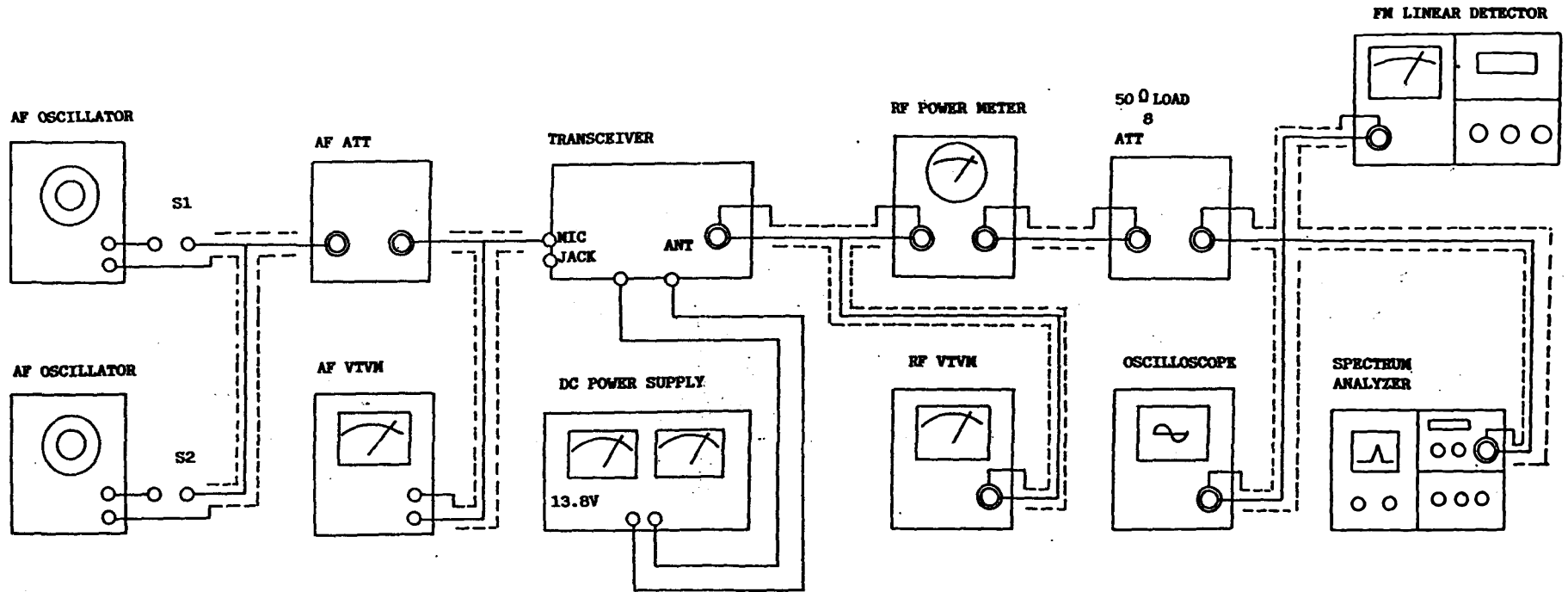

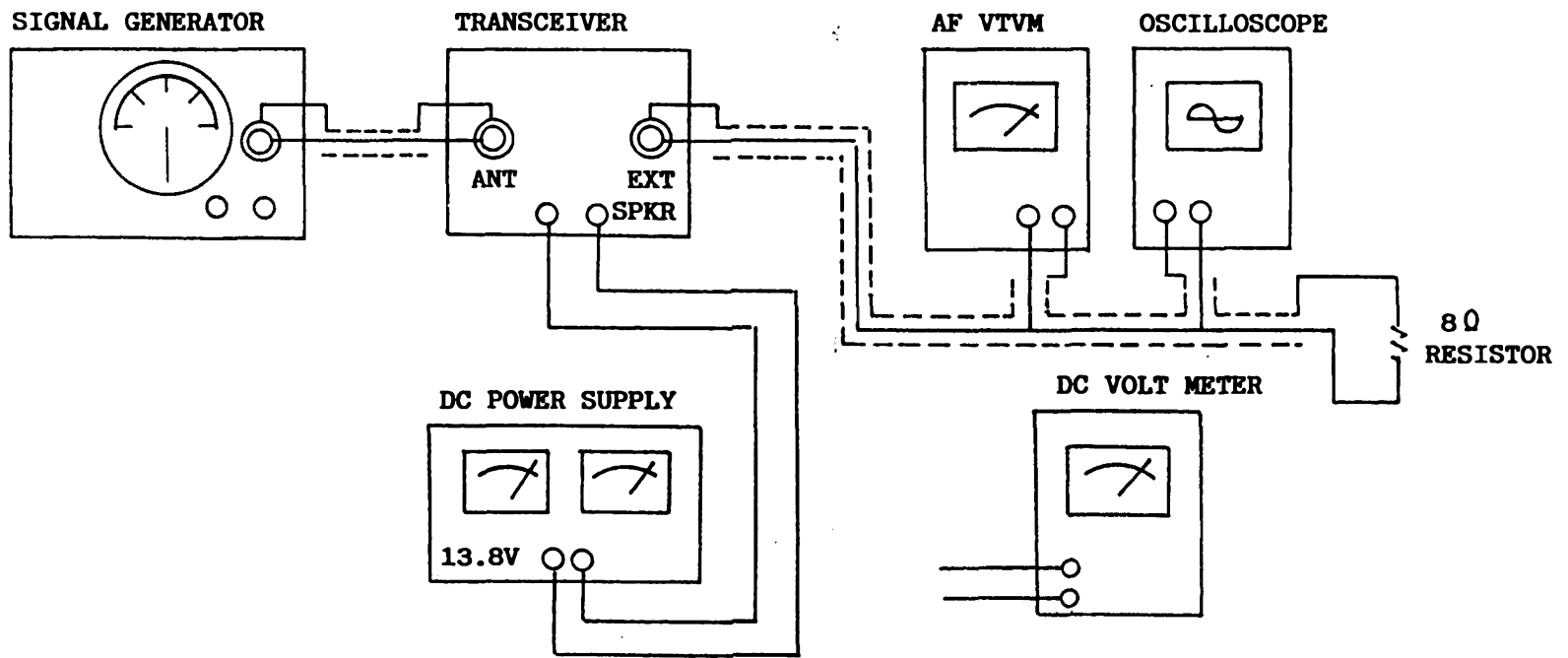

ALIGNMENT POINTS

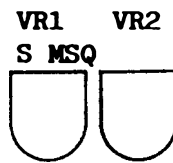
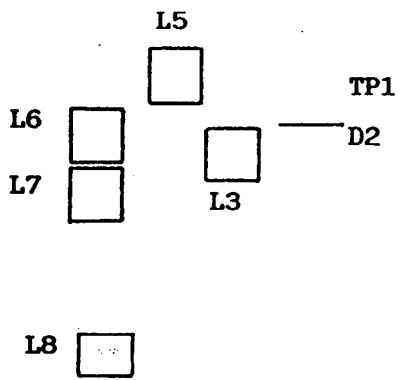

### 3. ALIGNMENT OF RECEIVER PORTION

#### a) Test Equipment Required

- RF SSG
- DC Voltmeter
- AF VTVM
- Oscilloscope

#### b) Alignment Procedure

Connect the AF VTVM and 8 ohm dummy load to EXT SP Jack during the alignment of receiver portion.

STEP	PRESET TO	ADJUSTMENT	REMARKS
1	Channel : 19 Band : C NB/ANL : OFF MOD, S/RF : S/RF PA/SQL : SQL Clari : Center RF GAIN : CW AF VOL : CW MODE : AM		Set RF SG to Channel 19 with 30%, 1kHz modulation.
2	Same as above	L6	Turn the core of L8 to CW. maximum at the bottom.
3	Same as above	L5, 7, 8 9	Set the Unit to C Band Channel 19 AM, adjust coils for maximum reading.
4	Same as above	L6	Set the unit to C Band Channel 1 AM (SSG Channel 1), adjust for maximum reading and then set 1/4 turn CCW.
5	Same as above	VR1	Set the SSG to 100uV output with no-modulation. Adjust VR1 to obtain "S-9" on transceiver's meter.
6	Same as above	VR2	Adjust VR2 to turn off the squelch circuit when SSG output comes up to 1000uV.
7	Same as step 1 except MODE : USB	L3	Set SSG to C Band Channel 18 USB with no-modulation, and output level is 5uV. Connect Oscilloscope to TP-1 (D2) so that adjust for maximum reading.
8	Same as Step 1 except Mode : FM	L4	Set the SSG to FM 1KHz, 1.5KHz Deviation 1mv. Adjust L4 to obtain the maximum indication on Oscilloscope.



ALIGNMENT POINTS

BIAS

L33

BIAS

L30

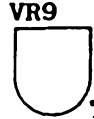

VR10

TP7



TP6



TP8

VR7  
RF.M



VR9  
ALC



VR12  
AMC



VR11  
AM PWR

L40

L41



L43

VR3  
MOD.M



VR4  
DEV



VR5  
CARRIER



VR6  
TX. FREQ.



**F. FREQUENCIES**

CHANNEL	A BAND MHZ	B BAND MHZ	C BAND MHZ	D BAND MHZ	E BAND MHZ
1	26.065	26.515	26.965	27.415	27.865
2	.075	.525	.975	.425	.875
3	.085	.535	.985	.435	.885
4	.105	.555	27.005	.455	.905
5	.115	.565	.015	.465	.915
6	.125	.575	.025	.475	.925
7	.135	.585	.033	.485	.935
8	.155	.605	.055	.505	.955
9	.165	.615	.065	.515	.965
10	.175	.625	.075	.525	.975
11	.185	.635	.085	.535	.985
12	.205	.655	.105	.555	28.005
13	.215	.665	.115	.565	.015
14	.225	.675	.125	.575	.025
15	.235	.685	.135	.585	.035
16	.255	.705	.155	.605	.055
17	.265	.715	.165	.615	.065
18	.275	.725	.175	.625	.075
19	.285	.735	.185	.635	.085
20	.305	.755	.205	.655	.105
21	.315	.765	.215	.665	.115
22	.325	.775	.225	.675	.125
23	.355	.805	.255	.705	.155
24	.335	.785	.235	.685	.135
25	.345	.795	.245	.695	.145
26	.365	.815	.265	.715	.165
27	.375	.825	.275	.725	.175
28	.385	.835	.285	.735	.185
29	.395	.845	.295	.745	.195
30	.405	.855	.305	.755	.205
31	.415	.865	.315	.765	.215
32	.425	.875	.325	.775	.225
33	.435	.885	.335	.785	.235
34	.445	.895	.345	.795	.245
35	.455	.905	.355	.805	.250
36	.465	.915	.365	.815	.265
37	.475	.925	.375	.825	.275
38	.485	.935	.385	.835	.285
39	.495	.945	.395	.845	.295
40	.505	.955	.405	.855	.305

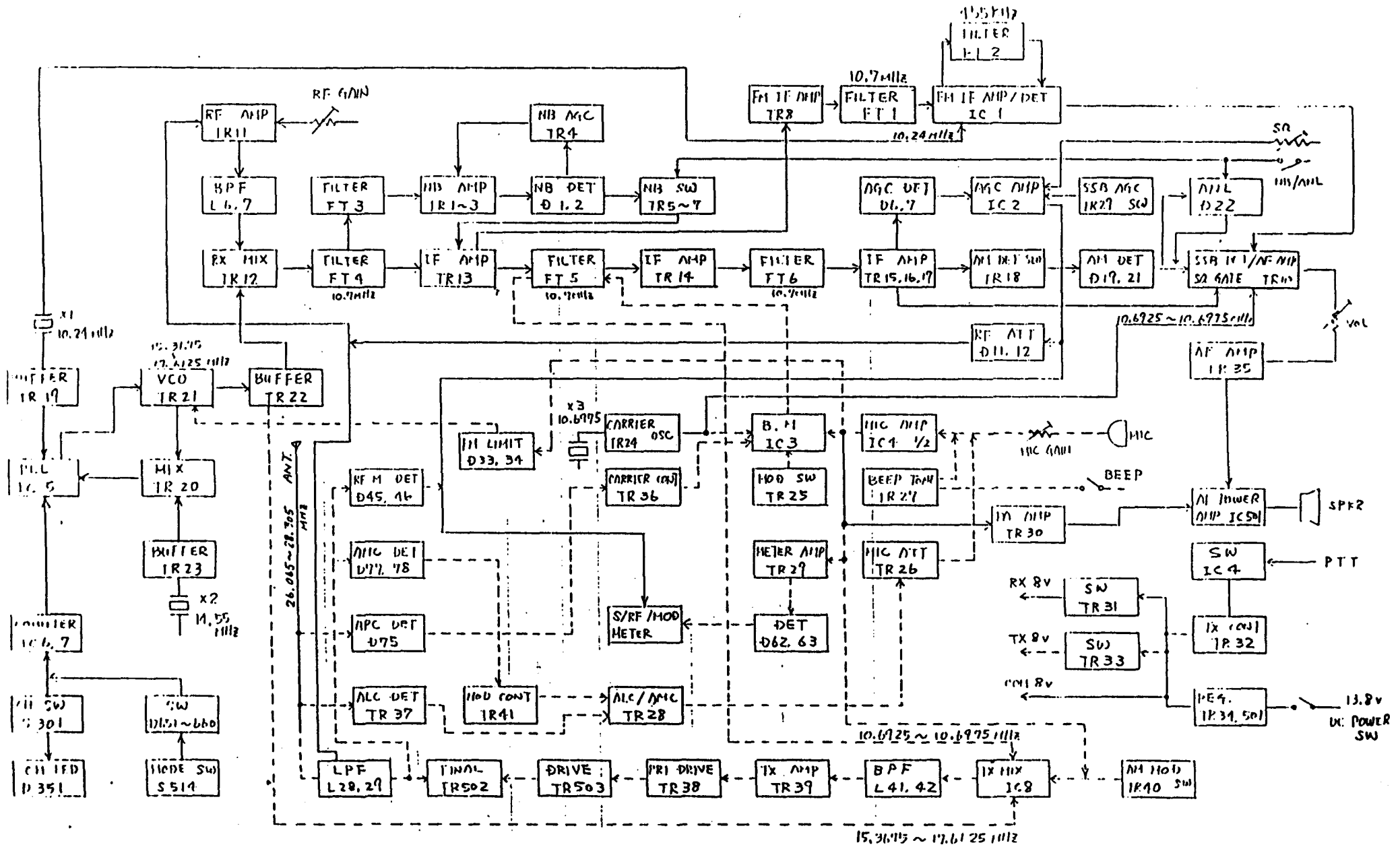

- - - TX  
 ——— RX

JACKSON  
 UT-517  
 BLOCK DIAGRAM

## BRANCHEMENT PRISE MICRO 6 BROCHES NC 518

N° BROCHES	DESIGNATION CABLES
1	Modulation
2	RX
3	TX
4	Non connectée
5	Masse
6	Alimentation

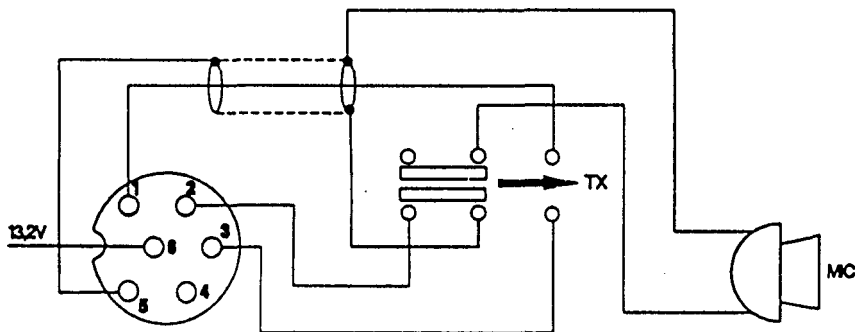

ATTENTION BIEN VERIFIER LE BRANCHEMENT DE LA BROCHE 6

SUCCURSALE «ILE DE FRANCE»  
50/56, Rue du Pré des Aulnes - Parc d'activités des Arpents  
77340 PONTAULT- COMBAULT  
Tél : (1) 60.29.28.27 - Fax : (1) 60.28.44.00

## BRANCHEMENT PRISE MICRO 4 BROCHES NC 514

N° BROCHES

1  
2  
3  
4

DESIGNATION CABLES

Masse  
Modulation  
TX  
RX

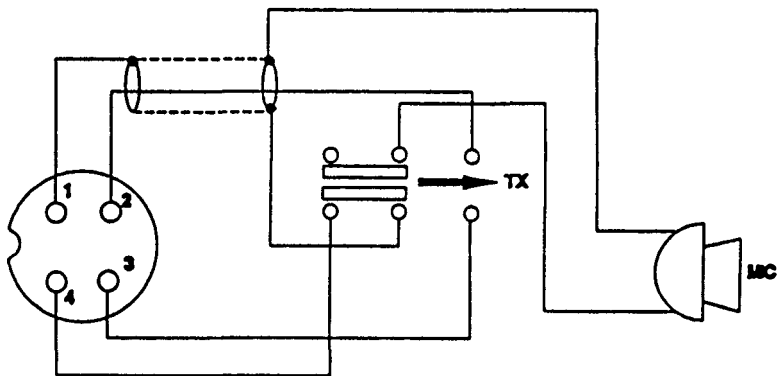

JACKSON

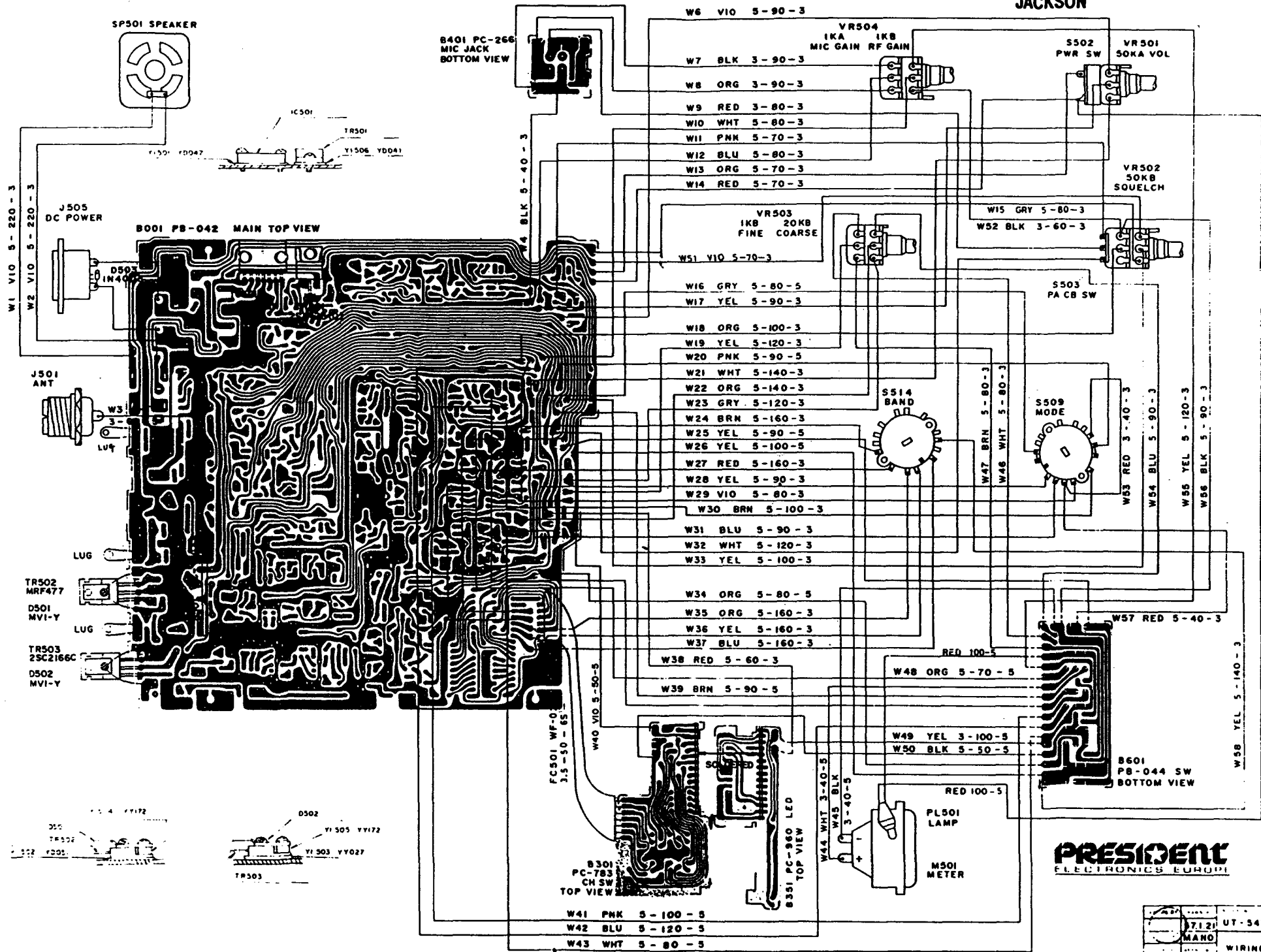

**PRESIDENT**  
ELECTRONICS EUROPE

7121	UT-547
MANO	WIRING DIAGRAM
E 32-2212	

SP501 SPEAKER

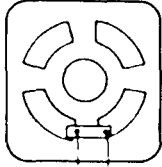

B401 PC-266  
MIC JACK  
BOTTOM VIEW

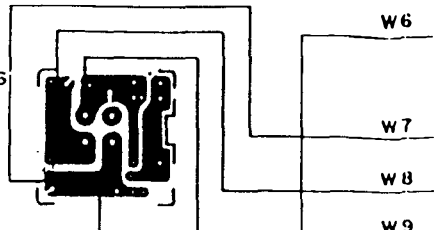

IC501

TR501

Y1501 Y0047

Y1506 Y0041

W1 VIO 5-220-3  
W2 VIO 5-220-3

J505  
DC POWER

B001 PB-042 MAIN TOP VIEW

D503  
IN4001

J501  
ANT

W3  
3-6  
LUG

TR502  
MRF477

D501  
MVI-Y

LUG

TR503  
2SC2166C  
D502  
MVI-Y

LUG

W4 BLK 5-40-3

- W6
- W7
- W8
- W9
- W10
- W11
- W12
- W13
- W14
- W51 V
- W16
- W17
- W18
- W19
- W20
- W21
- W22
- W23
- W24
- W25
- W26
- W27
- W28
- W29
- W3
- W31
- W32
- W33
- W34
- W35
- W36
- W37
- W38 RED
- W39 BRN

FC501 WF-0  
3.5-50-65

W40 VIO 5-50-5

B301  
PC-783  
CH SW  
TOP VIEW

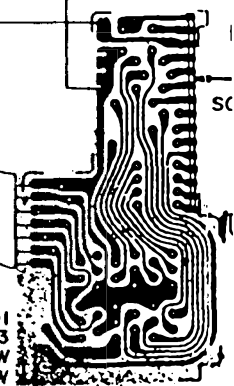

- W41 PNK 5-100-5
- W42 BLU 5-120-5
- W43 WHT 5-80-5

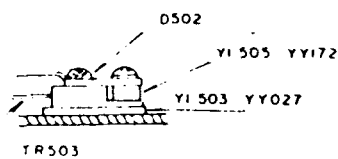
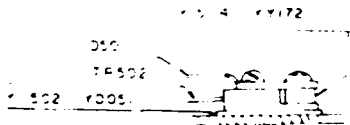

# JACKSON

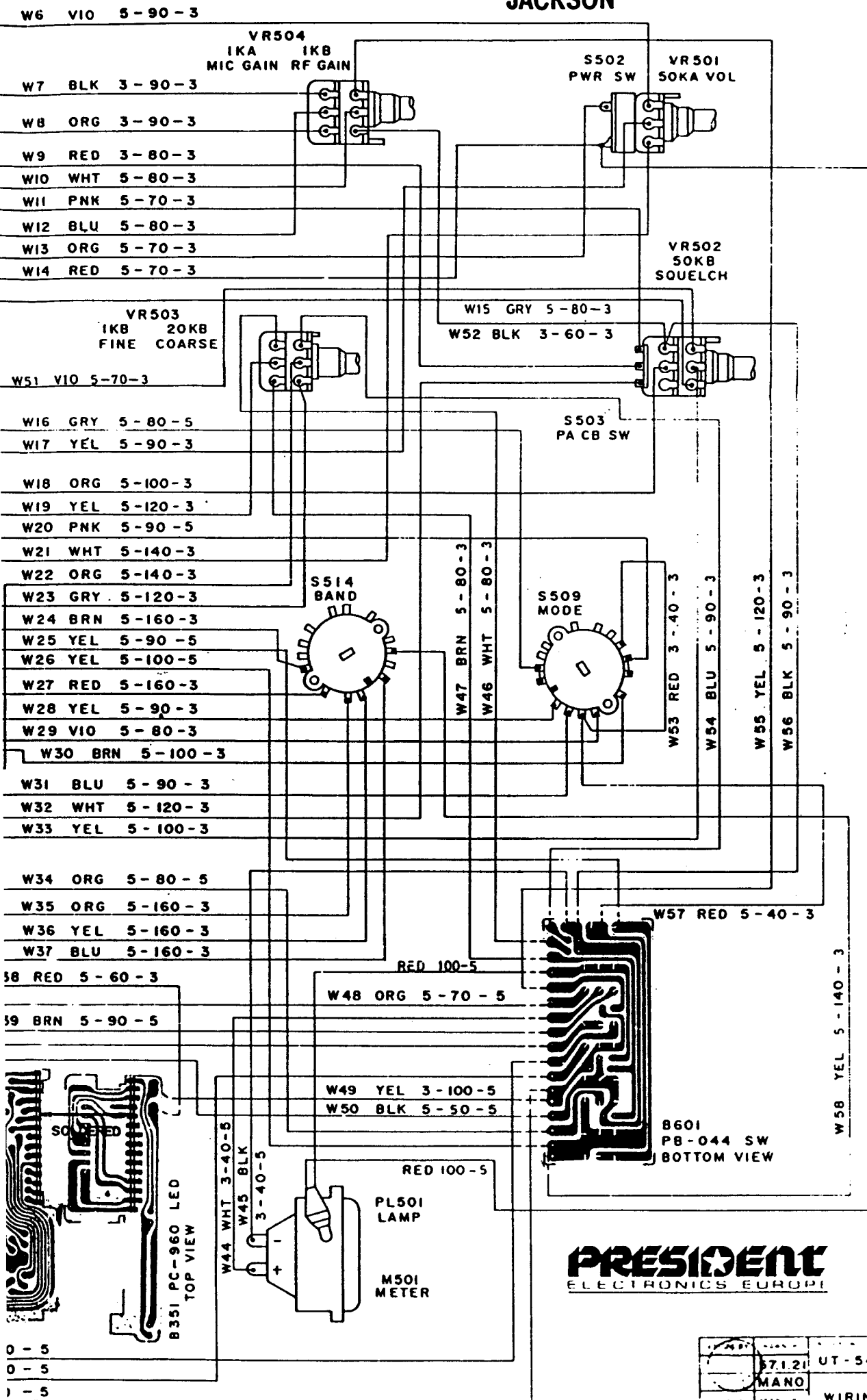

**PRESIDENT**  
ELECTRONICS EUROPE

7.1.21	UT-547
MANO	WIRING DIAGRAM
E32-2212	



PB-042AB

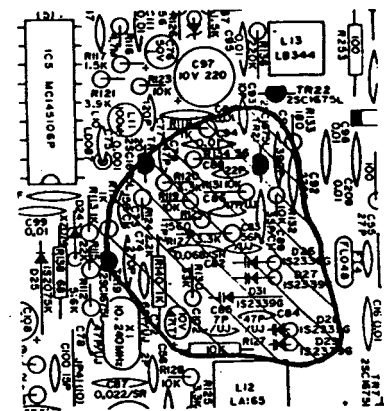
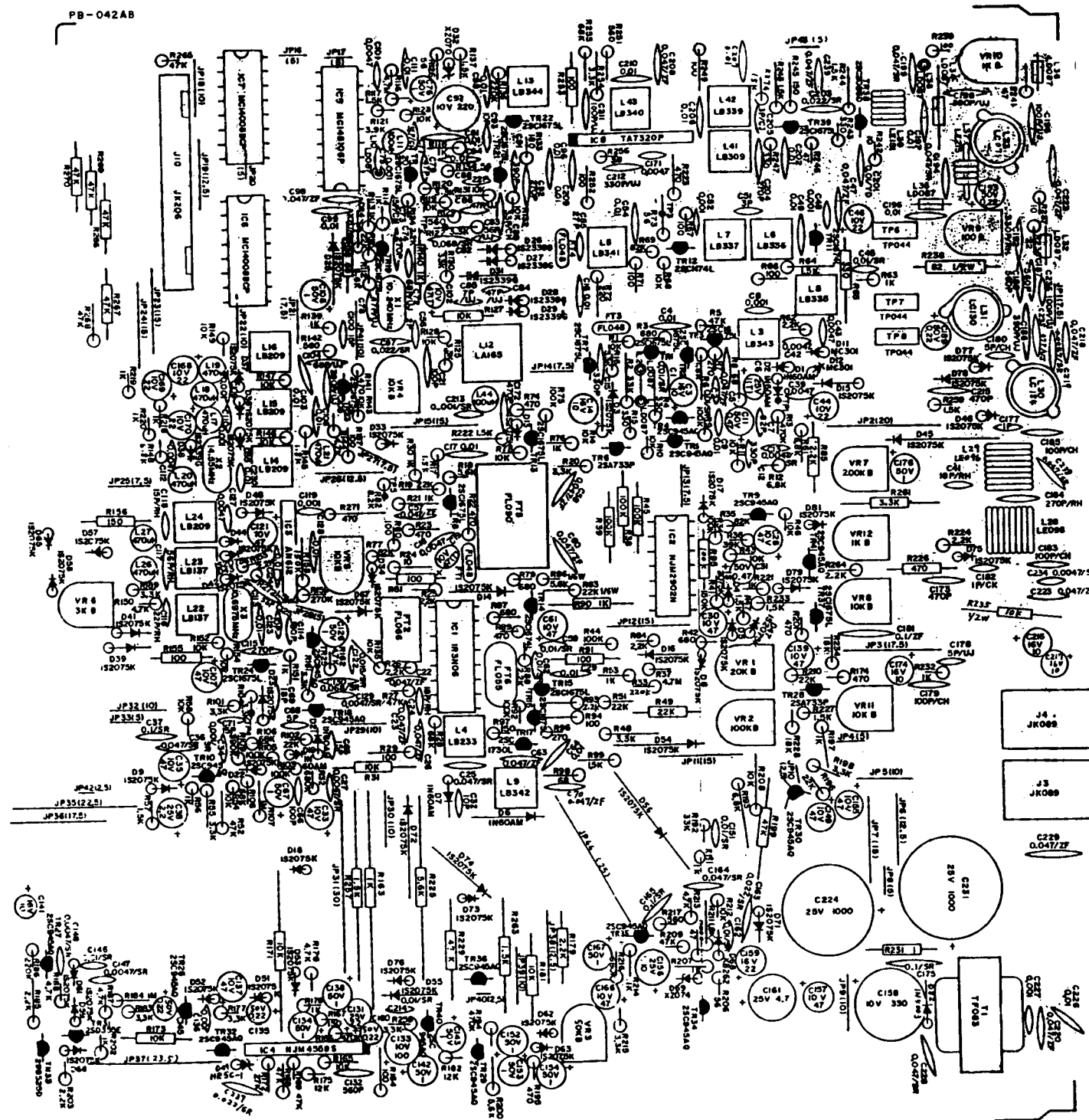

ALL DIMENSIONS ARE IN MILLIMETERS UNLESS OTHERWISE SPECIFIED.  
 ALL DIMENSIONS ARE TO CENTER UNLESS OTHERWISE SPECIFIED.  
 ALL DIMENSIONS ARE TO CENTER UNLESS OTHERWISE SPECIFIED.

UT-547	58.1.11
MAIN PCB	TANARA
PARTS ASSEMBLY TOP VIEW	
E22-4674	
NIDEN COP	

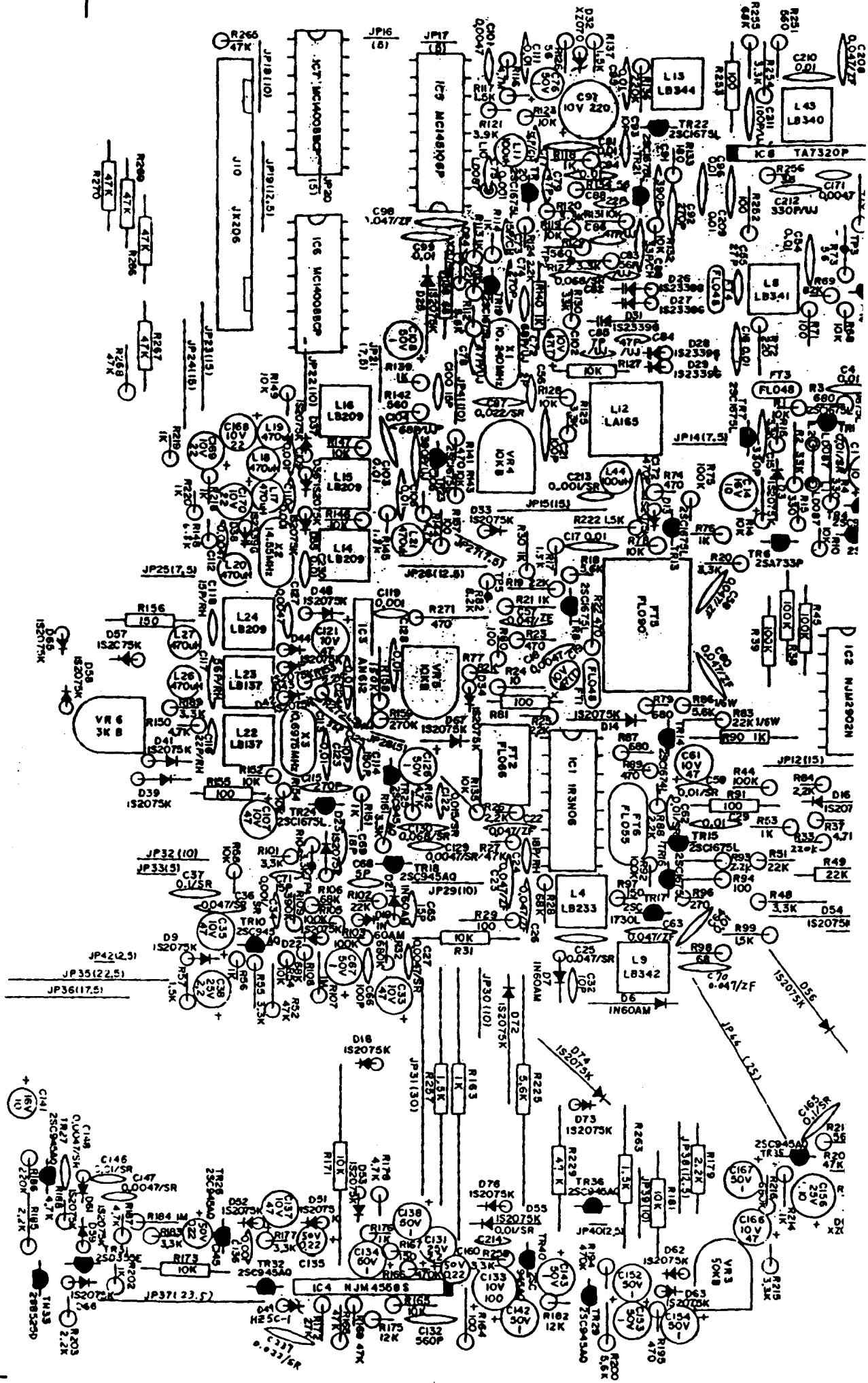

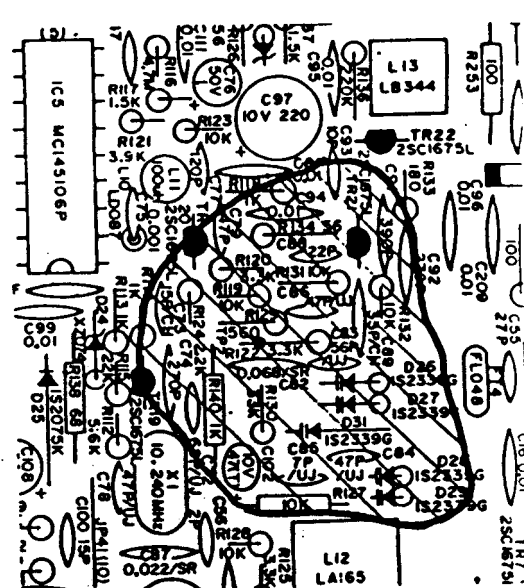
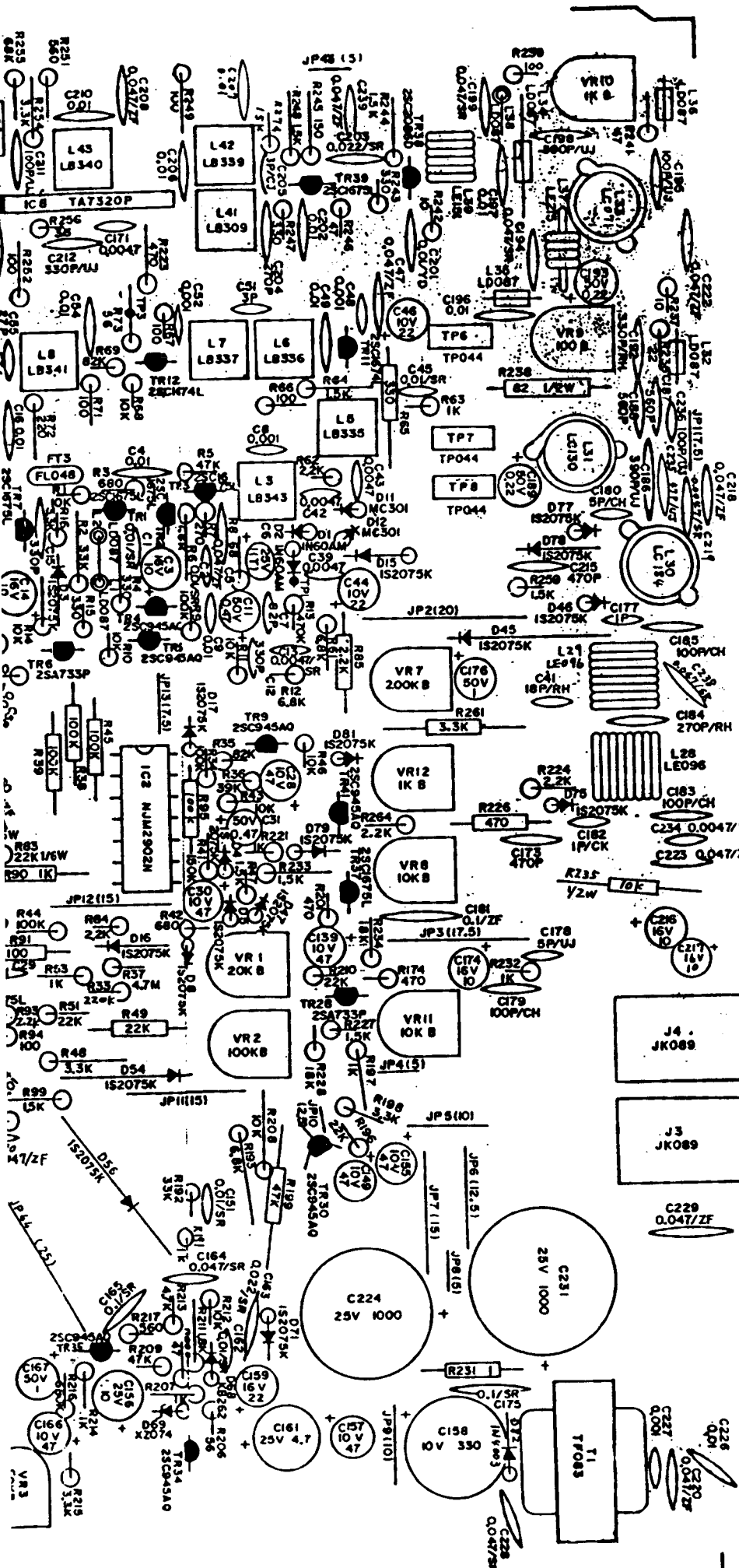

NOTE:  
RESISTOR WATTAGES ARE 1/4W UNLESS OTHERWISE NOTED.  
CALL CAPACITORS TEMPERATURE CHARACTERISTICS UNLESS THAN 50% R.F. OR MORE THAN UNLESS OTHERWISE NOTED.

58.1.11	UT-547
TAMAKA	MAIN PCB
	PARTS ASSEMBLY TOP VIEW
<b>E22-4674</b>	
INDEN COP	

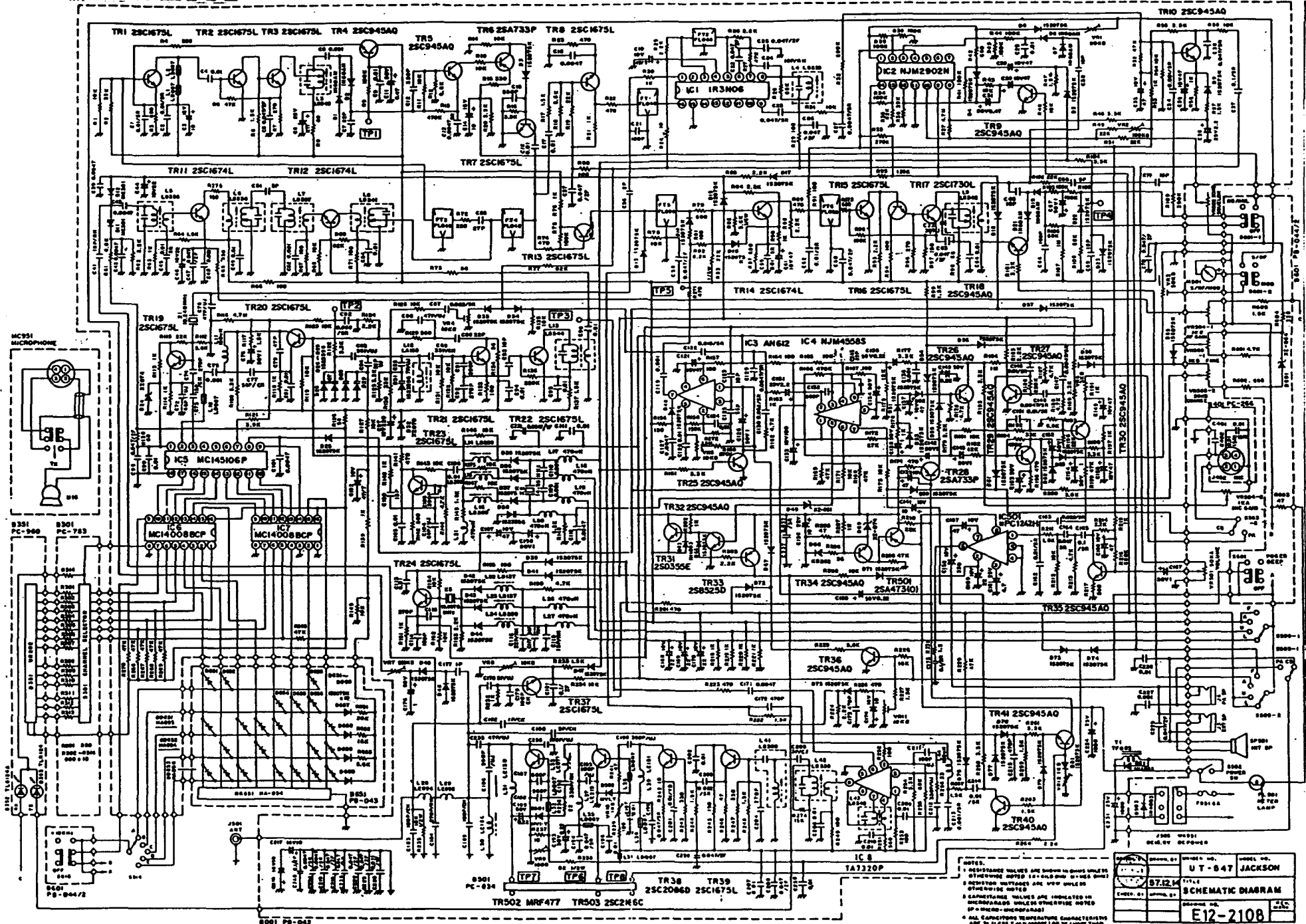

NOTES:  
1. RESISTANCE VALUES ARE SHOWN IN OHMS UNLESS OTHERWISE NOTED (K=KILOHMS, M=MEG OHMS)  
2. CAPACITANCE VALUES ARE SHOWN IN PICOFARADS UNLESS OTHERWISE NOTED (P=PICOFARAD)  
3. ALL CAPACITORS TEMPERATURE CHARACTERISTICS ARE TO BE 50% TOLERANCE (SEE TYPICAL CHARACTERISTICS UNLESS OTHERWISE NOTED)

REV. NO.	97.12	MODEL NO.	UT-847 JACKSON
TITLE	SCHEMATIC DIAGRAM		
REV. 01		REV. 01	
DATE		DATE	
E12-2108		UNIDEN CORP.	

# PRESIDENT

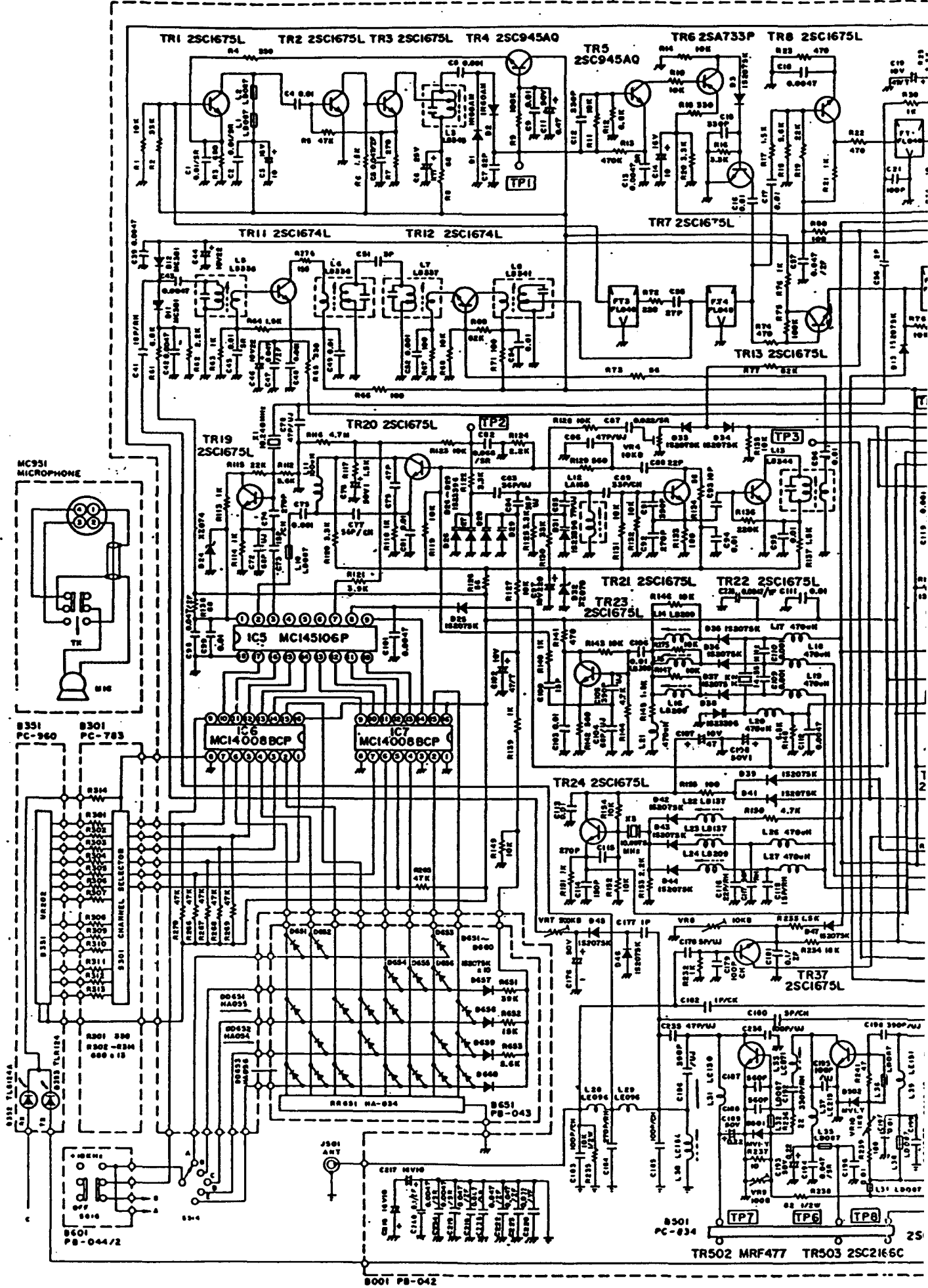

# JACKSON N

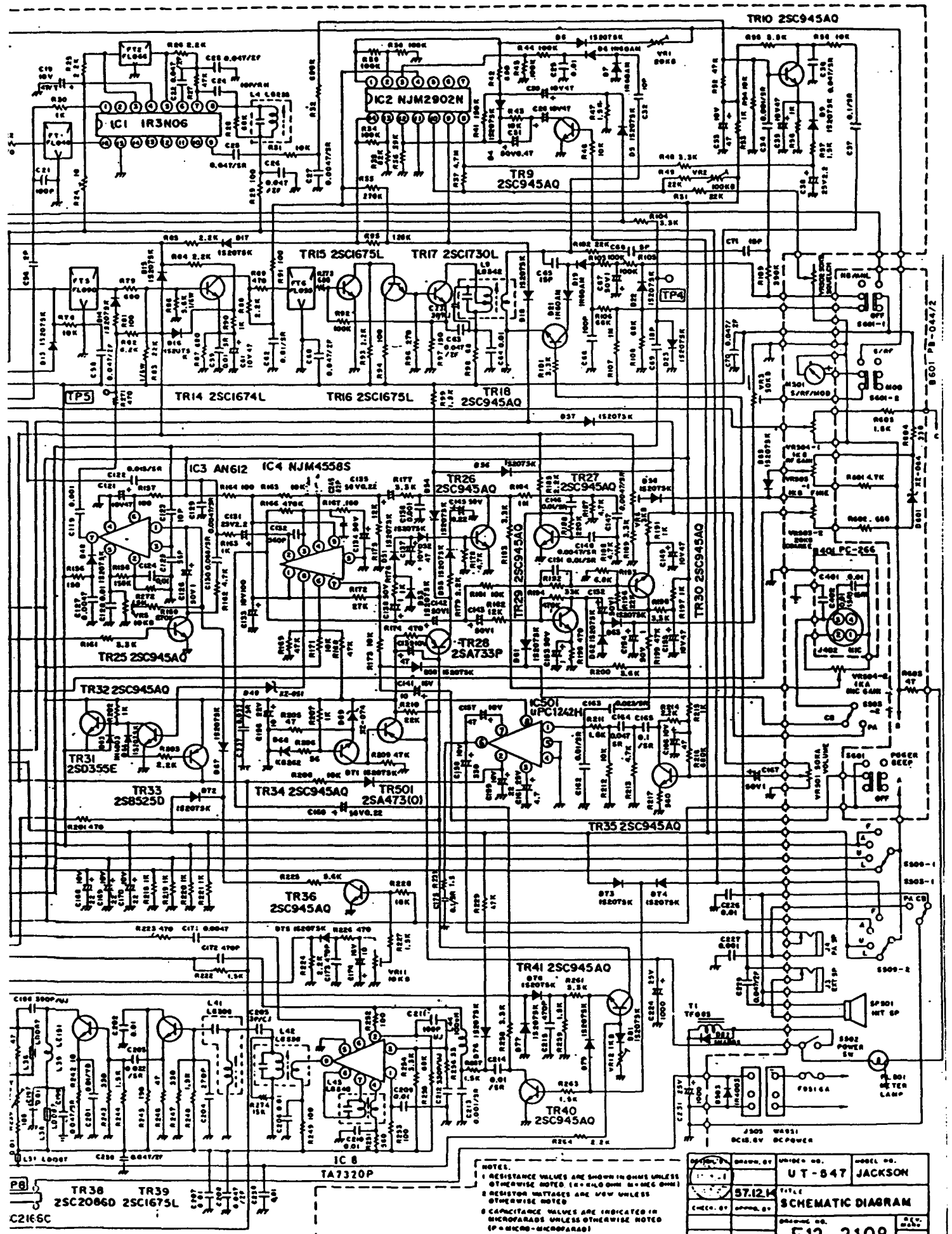

- NOTES:
- 1. RESISTANCE VALUES ARE SHOWN IN OHMS UNLESS OTHERWISE NOTED. (R = 100 OHMS, M = 1000 OHMS)
  - 2. RESISTOR NETWORKS ARE 5% UNLESS OTHERWISE NOTED
  - 3. CAPACITANCE VALUES ARE INDICATED IN MICROFARADS UNLESS OTHERWISE NOTED (P = MICRO-MICROFARAD)
  - 4. ALL CAPACITORS TEMPERATURE CHARACTERISTICS ARE 5% UNLESS OTHERWISE NOTED

DRAWN BY	WORK NO.	MODEL NO.
57.12K	UT-547	JACKSON
CHECK BY	DATE	TITLE
		SCHEMATIC DIAGRAM
		DRAWING NO.
		E12-2108
		UNIDEN CORP.

TR38 TR39  
ZSC20860 ZSC1675L  
C21E6C

1.601 PB-04872

5300-1  
5300-1

5300-2

5300-1  
5300-1

5300-2

5300-1  
5300-1

## LISTE PIECES DETACHEES JACKSON

## LISTE PIECES DETACHEES JACKSON

CODE	DESIGNATION	QTE/MOD.	CODE	DESIGNATION	QTE/MOD.
BC003	BOBINE LD-087	8	DC008	DIODE 1N4003	2
BC004	BOBINE LE-096	2	DC009	DIODE MV-1Y	2
BC005	BOBINE LE-151	1	DC010	DIODE ZENER XZ-051	1
BC008	BOBINE LE-215	1	DC011	DIODE ZENER XZ-070	1
BC009	SELF LZ-016 100UH	2	DC012	DIODE ZENER XZ-074	2
BC010	SELF LZ-016 470UH	7	DC013	DIODE ZENER XZ-064	1
BC011	TRANSFORMATEUR TF-083	1	DC014	DIODE HA-034	1
BC015	BOBINE LC-071	2	DC015	DIODE HA-054	1
BC016	BOBINE LC-130	1	DC016	DIODE HA-055	1
BR003	BOBINE LA-165	1	DC017	DIODE HA-056	1
BR015	BOBINE LB-137	2	DV002	DIODE 1S2339G	6
BR016	BOBINE LB-209	4	DV003	DIODE KB-262	1
BR022	BOBINE LB-233	1	HM001	MICROPHONE MK-221	1
BR023	BOBINE LB-309	1	HP001	HAUT-PARLEUR SP-053	1
BR024	BOBINE LB-335	1	IL001	CICUIT INTEGRE MC14008BCP	2
BR025	BOBINE LB-336	1	IP001	CIRCUIT INTEGRE UPC1182H	1
BR026	BOBINE LB-337	1	IR001	CIRCUIT INTEGRE AN612	1
BR027	BOBINE LB-339	1	IR005	CIRCUIT INTEGRE NJM2902N	1
BR028	BOBINE LB-340	1	IR006	CIRCUIT INTEGRE NJM4558S	1
BR029	BOBINE LB-341	1	IR007	CIRCUIT INTEGRE TA7320P	1
BR030	BOBINE LB-342	1	IR008	CIRCUIT INTEGRE IR3N06	1
BR031	BOBINE LB-343	1	IS002	CIRCUIT INTEGRE MC145106P	1
BR032	BOBINE LB-344	1	JX001	JACK JK-089	2
DC001	DIODE 1N60 AM	6	JX002	JACK JK-052	1
DC005	DIODE 1S2075K	63	JX003	JACK JK-068	1
DC007	DIODE MC-301	2	JX004	JACK JK-206	1

## LISTE PIECES DETACHEES JACKSON

## LISTE PIECES DETACHEES JACKSON

2

CODE	DESIGNATION	QTE/MOD.	CODE	DESIGNATION	QTE/MOD.
JX005	JACK JK-087	1	TX002	TRANSISTOR 2SC945A-Q	16
JX006	JACK JK-075	1	TX003	TRANSISTOR 2SC1674-L	3
OA001	AFFICHEUR UR-202D	1	TX004	TRANSISTOR 2SC1675-L	16
OX001	LED TLR-124 RED	1	TX005	TRANSISTOR 2SC1730-L	1
OX002	DIODE / LED TLG-124A GREEN	1	TX009	TRANSISTOR 2SB525-D	1
PF001	FILTRE FL-04B SFE10.7MS2-M	3	TX010	TRANSISTOR 2SC2086-D	1
PF002	FILTRE FL-066	1	TX011	TRANSISTOR 2SD355-E	1
PF004	FILTRE FL-055 10M-7A1	1	VM002	VU-METRE MT-221	1
PF005	FILTRE FL-090 UMF-058	1			
PQ002	QUARTZ 10.6975	1			
PQ005	QUARTZ 10.240 QX-074	1			
PQ006	QUARTZ 14.550	1			
QX002	FACE AVANT JACKSON	1			
RV002	POTENTIOMETRE RV-320 50KA	1			
RV003	POTENTIOMETRE RV-447 50KB	1			
RV004	POTENTIOMETRE RV-485 1KB.1KA	1			
RV005	POTENTIOMETRE RV-560 20KB.1KB	1			
SS001	COMMUTATEUR SR-208	1			
SX001	FUSIBLE FS-014 6A	1			
SX002	COMMUTATEUR SR-187	1			
SX004	COMMUTATEUR SW-317	1			
SX005	COMMUTATEUR SR-342	1			
TB001	TRANSISTOR 2SA473-0	1			
TH001	TRANSISTOR 2SC2166-C	1			
TH003	TRANSISTOR MRF-477	1			
TX001	TRANSISTOR 2SA733-P	2			



UNIDEN PRESIDENT "JACKSON" (Export Model)

- VR1-S/Meter
- VR2-Sq range
- VR3-Mod Meter
- VR4-PM Dev.
- VR5-Car. Bal.
- VR6-TX Freq.
- VR7-RP Meter
- VR8-ALC
- VR9-Final Bias
- VR10-Driver Bias
- VR11-AM PWR
- VR12-AMC

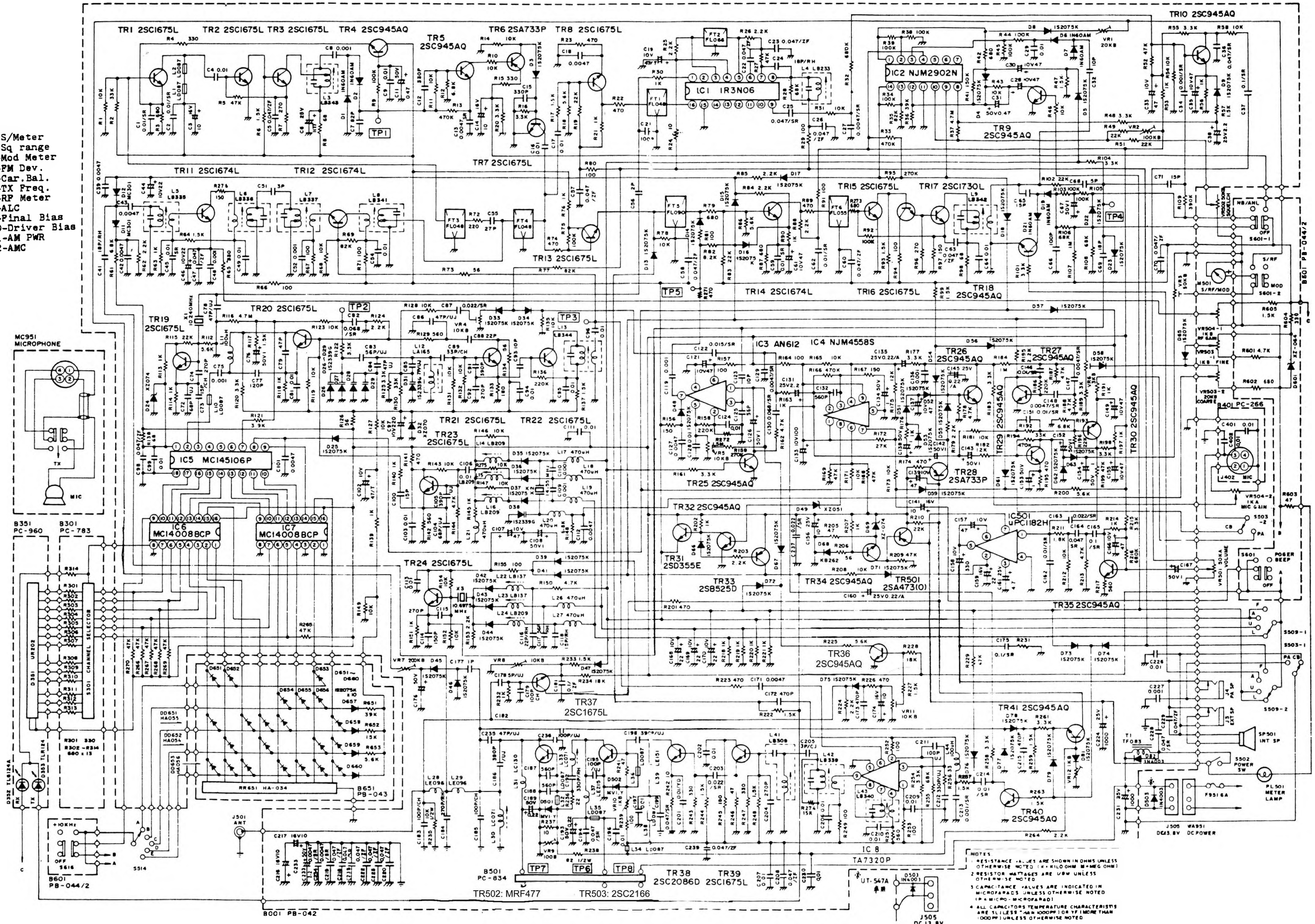

NOTES:  
 1. RESISTANCE VALUES ARE SHOWN IN OHMS UNLESS OTHERWISE NOTED (K = KILOHMS, M = MEG OHMS)  
 2. RESISTOR RATINGS ARE LOW UNLESS OTHERWISE NOTED  
 3. CAPACITANCE VALUES ARE INDICATED IN MICROFARADS UNLESS OTHERWISE NOTED (P = PICO, MICROFARAD)  
 4. ALL CAPACITORS TEMPERATURE CHARACTERISTICS ARE 5% LESS THAN 100PPM/°C IF MORE THAN 100PPM UNLESS OTHERWISE NOTED