

PRESIDENT

JOHNNY II ASC

HARRY II classic

HARRY II ASC

SERVICE MANUAL

-TECNICAL CHARACTERITICS

JOHNNY II ASC (config: E EU PL)

HARRY II classic (config: E d d2 EU EC U PL,without ASC)

HARRY II ASC (config: E d d2 EU EC U PL)

1-GENERAL:

-Multiconfiguration(E,d,d2,EU,EC,U,PL)

-E ⇒ 40 channels AM/FM 4W (from 26,965Mhz to 27,405Mhz)

-d ⇒ 80 channels FM 4W (from 26,565Mhz to 27,405Mhz)

12 channels AM 1W (from 27,005Mhz to 27,135Mhz)

-d2 ⇒ 40 channels FM 4W (from 26,565Mhz to 27,405Mhz)

12 channels AM 1W (from 27,005Mhz to 27,135Mhz)

-EU ⇒ 40 channels FM 4W/AM 1W (from 26,965Mhz to 27,405Mhz)

-EC ⇒ 40 channels FM 4W (from 26,965Mhz to 27,405Mhz)

-U ⇒ 40 channels FM 4W (from 26,965Mhz to 27,405Mhz)

40 channels FM 4W (from 27,60125Mhz to 27,99125Mhz)

-PL ⇒ 40 channels AM/FM 4W (from 26,960Mhz to 27,400Mhz)

-Channel step

-10KHz

-Class of emission

-AM(A3E)/FM(F3E)

-Power supply

-13,2V (from 10,8V to 15,6V)

-Antenna impedance

-50Ω

-Dimensions(in mm)

-115(L)x180(H)x35(D)

-Weight

-0,8Kg

2-TRANSMISSION:

-Frequency allowance

-±300Hz

-Transmission interference

-Inferior to 4nW(-54dBm)

-Audio frequency response

-From 300Hz to 3kHz in AM/FM

-Emitted power in the adjacent channel

-Inferior to 20μW

-Microphone sensitivity

-Inferior to 10mV

-Current drain

-1,7A(in transmission mode with modulation)

-Modulated signal distortion

-Inferior to 2%

3-RECEPTION:

-Maximum sensitivity at 20dB sinad

-0,5 μ V(-113dBm) AM/FM

-Audio frequency response

-From 300Hz to 3kHz in AM/FM

-Adjacent channel selectivity

-Superior to 60dB

-Frequency image rejection

-Superior to 60dB

-Intermodulation response

-Superior to 54dB

-Maximum audio power

-5W

-Squelch sensitivity

-Threshold 0,2 μ V(-120dBm)/Tight 1mV(-47dBm)

-Current drain

-500mA nominal/800mA maximum

ALIGNMENT PROCEDURE

(JOHNNY II ASC/HARRY II classic/ HARRY II ASC)

*** VCO/PLL PORTION**

- Alignment procedure
- Test points
- Frequencies chart

*** TRANSMITTER**

- Alignment procedure
- Test points

*** RECEIVER**

- Alignment procedure
- Test points

Test equipment required

Frequency counter 200 Mhz	HF Generator
DC Voltmeter	BF Voltmeter
Distortimeter	HF Voltmeter
Wattmeter - Dummy load	Osilloscope
FM linear detector	Load 8 Ω
AF generator	Sinad meter

Conditions of Measurements on HF Generator

Reception

AM mode: Level - 107 dBm Frequency 1 KHz with 60% of modulation.

FM mode: Level - 107 dBm Frequency 1 KHz with 1,2KHz of deviation.

Transmission

Frequency 1 KHz 30mV.

ALIGNMENT VCO/PLL

1 - Alignment procedure(13,2V;configuration"EU,E,d")

STEP	CONDITION	ADJUSTMENT	REMARKS OF ADJUSTMENT
1	FM(EU,E) TX mode Channel 40	L361	Connect a voltmeter to TP 301, adjust L361 to reach $3,2V \pm 0,2V$.
2	FM(EU,E) RX mode Channel 40	L360	Connect a voltmeter to TP 301, adjust L360 to reach $2,6V \pm 0,2V$.
3	FM(EU,E) TX/RX mode Channel 1		Connect a voltmeter to TP 301,and check: Rx Channel 1= $2,2V \pm 0,2V$ Tx Channel 1= $2,5V \pm 0,2V$
4	FM(EU,E) RX mode Channel 20	CT301	Connect a frequency counter to TP302,and adjust CT301 to reach 37,900MHz.
5	FM(EU,E) TX/RX mode Channel 1 to 40 or 1 to 80(d)		Connect a frequency counter to TP302,and check frequencies.

VCO/PLL ALIGNMENT POINTS

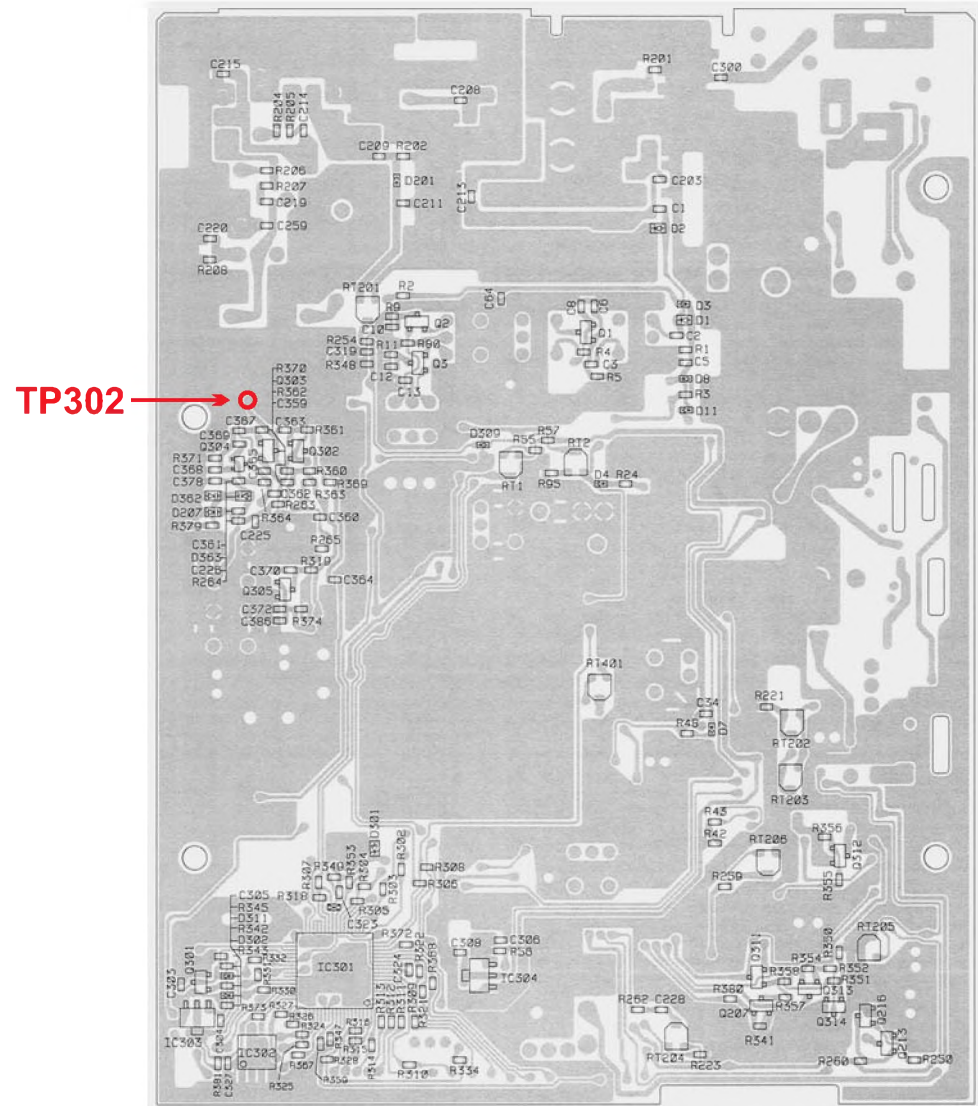
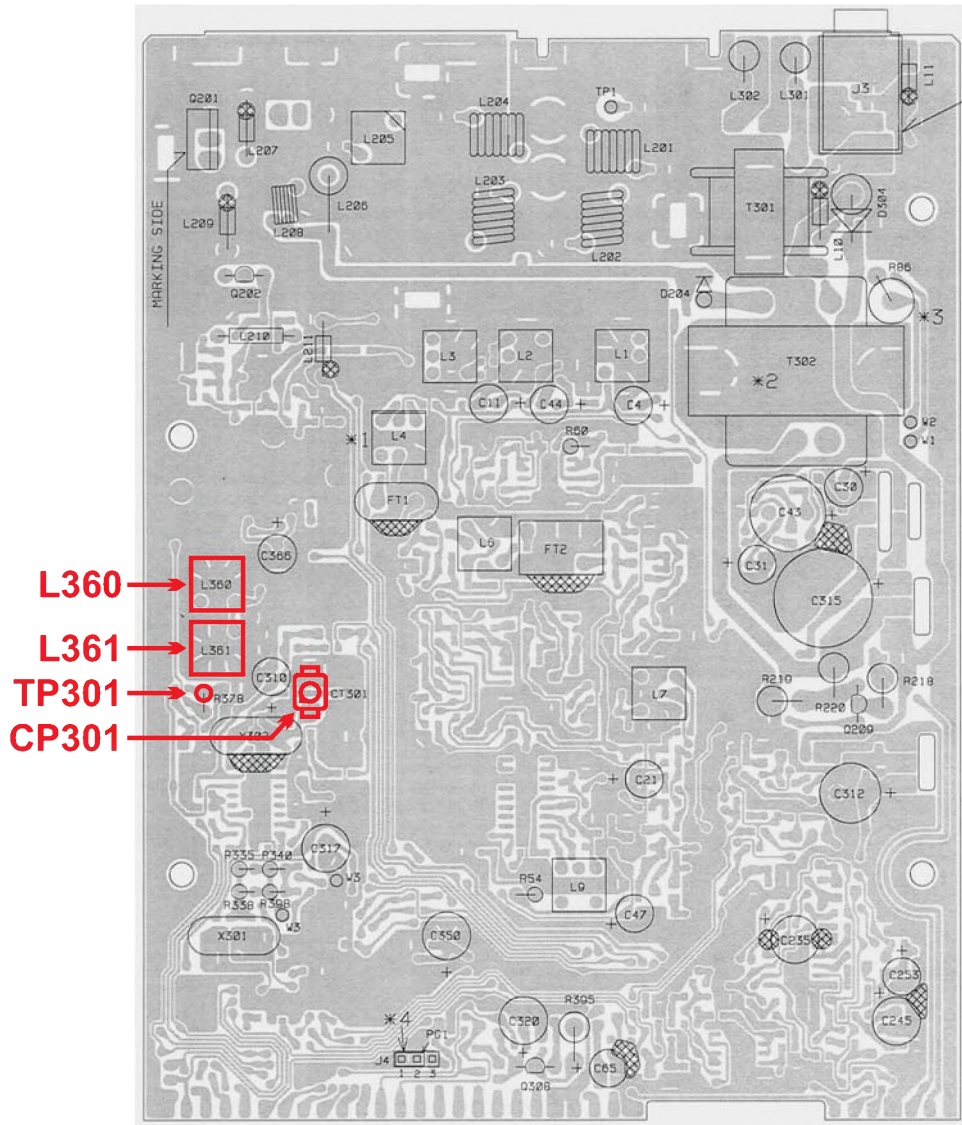

- FREQUENCY LIST (EU,E,EC,d2)

CH	Channels Frequencies (MHz)	VCO Frequencies (MHz)
1	26,965	37,660
2	26,975	37,670
3	26,985	37,680
4	27,005	37,700
5	27,015	37,710
6	27,025	37,720
7	27,035	37,730
8	27,055	37,750
9	27,065	37,760
10	27,075	37,770
11	27,085	37,780
12	27,105	37,800
13	27,115	37,810
14	27,125	37,820
15	27,135	37,830
16	27,155	37,850
17	27,165	37,860
18	27,175	37,870
19	27,185	37,880
20	27,205	37,900
21	27,215	37,910
22	27,225	37,930
23	27,255	37,950
24	27,235	37,930
25	27,245	37,940
26	27,265	37,960
27	27,275	37,970
28	27,285	37,980
29	27,295	37,990
30	27,305	38,000
31	27,315	38,010
32	27,325	38,020
33	27,335	38,030
34	27,345	38,040
35	27,355	38,050
36	27,365	38,060
37	27,375	38,070
38	27,385	38,080
39	27,395	38,090
40	27,405	38,100

- FREQUENCY LIST (PL)

CH	Channels Frequencies (MHz)	VCO Frequencies (MHz)
1	26,960	37,655
2	26,970	37,665
3	26,980	37,675
4	27,000	37,695
5	27,010	37,705
6	27,020	37,715
7	27,030	37,725
8	27,050	37,745
9	27,060	37,755
10	27,070	37,765
11	27,080	37,775
12	27,100	37,795
13	27,110	37,805
14	27,120	37,815
15	27,130	37,825
16	27,150	37,845
17	27,160	37,855
18	27,170	37,865
19	27,180	37,875
20	27,200	37,895
21	27,210	37,905
22	27,220	37,915
23	27,250	37,945
24	27,230	37,925
25	27,240	37,935
26	27,260	37,955
27	27,270	37,965
28	27,280	37,975
29	27,290	37,985
30	27,300	37,995
31	27,310	38,005
32	27,320	38,015
33	27,330	38,025
34	27,340	38,035
35	27,350	38,045
36	27,360	38,055
37	27,370	38,065
38	27,380	38,075
39	27,390	38,085
40	27,400	38,095

- FREQUENCY LIST (U)

CH CEPT	Channels Frequencies (MHz)	VCO Frequencies (MHz)
1	26,965	37,660
2	26,975	37,670
3	26,985	37,680
4	27,005	37,700
5	27,015	37,710
6	27,025	37,720
7	27,035	37,730
8	27,055	37,750
9	27,065	37,760
10	27,075	37,770
11	27,085	37,780
12	27,105	37,800
13	27,115	37,810
14	27,125	37,820
15	27,135	37,830
16	27,155	37,850
17	27,165	37,860
18	27,175	37,870
19	27,185	37,880
20	27,205	37,900
21	27,215	37,910
22	27,225	37,930
23	27,255	37,950
24	27,235	37,930
25	27,245	37,940
26	27,265	37,960
27	27,275	37,970
28	27,285	37,980
29	27,295	37,990
30	27,305	38,000
31	27,315	38,010
32	27,325	38,020
33	27,335	38,030
34	27,345	38,040
35	27,355	38,050
36	27,365	38,060
37	27,375	38,070
38	27,385	38,080
39	27,395	38,090
40	27,405	38,100

- FREQUENCY LIST (U)

CH ENG	Channels Frequencies (MHz)	VCO Frequencies (MHz)
1	27,60125	38,29625
2	27,61125	38,30625
3	27,62125	38,31625
4	27,63125	38,32625
5	27,64125	38,33625
6	27,65125	38,34625
7	27,66125	38,35625
8	27,67125	38,36625
9	27,68125	38,37625
10	27,69125	38,38625
11	27,70125	38,39625
12	27,71125	38,40625
13	27,72125	38,41625
14	27,73125	38,42625
15	27,74125	38,43625
16	27,75125	38,44625
17	27,76125	38,45625
18	27,77125	38,46625
19	27,78125	38,47625
20	27,79125	38,48625
21	27,80125	38,49625
22	27,81125	38,50625
23	27,82125	38,51625
24	27,83125	38,52625
25	27,84125	38,53625
26	27,85125	38,54625
27	27,86125	38,55625
28	27,87125	38,56625
29	27,88125	38,57625
30	27,89125	38,58625
31	27,90125	38,59625
32	27,91125	38,60625
33	27,92125	38,61625
34	27,93125	38,62625
35	27,94125	38,63625
36	27,95125	38,64625
37	27,96125	38,65625
38	27,97125	38,66625
39	27,98125	38,67625
40	27,99125	38,68625

- FREQUENCY LIST (d)

CH	Channels	VCO	CH	Channels	VCO
D	Frequencies (MHz)	Frequencies (MHz)	D	Frequencies (MHz)	Frequencies (MHz)
1	26,965	37,660	41	26,565	37,260
2	26,975	37,670	42	26,575	37,270
3	26,985	37,680	43	26,585	37,280
4	27,005	37,70	44	26,595	37,290
5	27,015	37,710	45	26,605	37,300
6	27,025	37,720	46	26,615	37,310
7	27,035	37,730	47	26,625	37,320
8	27,055	37,750	48	26,635	37,330
9	27,065	37,760	49	26,645	37,340
10	27,075	37,770	50	26,655	37,350
11	27,085	37,780	51	26,665	37,360
12	27,105	37,800	52	26,675	37,370
13	27,115	37,810	53	26,685	37,380
14	27,125	37,820	54	26,695	37,390
15	27,135	37,830	55	26,705	37,400
16	27,155	37,850	56	26,715	37,410
17	27,165	37,860	57	26,725	37,420
18	27,175	37,870	58	26,735	37,430
19	27,185	37,880	59	26,745	37,440
20	27,205	37,900	60	26,755	37,450
21	27,215	37,910	61	26,765	37,460
22	27,225	37,930	62	26,775	37,470
23	27,255	37,950	63	26,785	37,480
24	27,235	37,930	64	26,795	37,490
25	27,245	37,940	65	26,805	37,500
26	27,265	37,960	66	26,815	37,510
27	27,275	37,970	67	26,825	37,520
28	27,285	37,980	68	26,835	37,530
29	27,295	37,990	69	26,845	37,540
30	27,305	38,000	70	26,855	37,550
31	27,315	38,010	71	26,865	37,560
32	27,325	38,020	72	26,875	37,570
33	27,335	38,030	73	26,885	37,580
34	27,345	38,040	74	26,895	37,590
35	27,355	38,050	75	26,905	37,600
36	27,365	38,060	76	26,915	37,610
37	27,375	38,070	77	26,925	37,620
38	27,385	38,080	78	26,935	37,630
39	27,395	38,090	79	26,945	37,640
40	27,405	38,100	80	26,955	37,650

ALIGNMENT TRANSMITTER

1 - Alignment procedure(13,2V;configuration"EU,E")

STEP	CONDITION	ADJUSTMENT	REMARKS OF ADJUSTMENT
1	AM(EU) Channel 20	RT203(LOW)	Connect a wattmeter to jack antenna, adjust RT203 to reach 1W on the wattmeter.
2	FM(EU) Channel 20	RT202(HI)	Connect a wattmeter to jack antenna, adjust RT202 to reach 4W on the wattmeter.
3	Same as 2	RT201(RF-M)	Adjust RT201 so that the 4th led is lighting.
4	FM(EU) Mod 30 mV 1 KHz CH 20	RT204(DEV)	Adjust RT204 to reach +/- 1,5KHz of deviation.
5	AM(EU) Mod 30 mV 1 KHz CH 20	RT205(AMC)	Adjust RT205 to reach +/- 90% of modulation.
6	AM(E) Mod 30 mV 1 KHz CH 20	RT206(ALC)	Adjust RT206 to reach +/- 90% of modulation.

ALIGNMENT RECEIVER

1 - Alignment procedure(13,2V;configuration"EU,E,d")

STEP	CONDITION	ADJUSTMENT	REMARKS OF ADJUSTMENT
1	AM(EU,E) Channel 20 Middle volume level. No squelch active	L1-L2-L3 L4-L6-L7	Connect HF generator to jack antenna adjusted at (-107dBm 1KHz 60%), connect sinad meter to jack EXT speaker and adjust coils for maximum sensitivity(≥ 20 dB sinad).
2	FM(EU,E) Channel 20 Middle volume level No squelch active	L 9	Connect HF generator to jack antenna adjusted at (-107dBm 1KHz 1,2KHz Dev),connect sinad meter to jack EXT speaker and adjust L9 for maximum sensitivity(≥ 20 dB sinad).
3	AM(EU,E) Channel 20 Middle volume level No squelch active	RT2(S-METER)	Connect HF generator to jack antenna adjusted at (-67dBm 1KHz 60%) and adjust RT2 so that the 4th led is lighting.
4	AM(EU,E) Channel 20 Middle volume level Squelch maximum clockwise	RT1(SQ)	Connect HF generator to jack antenna adjusted at (-47dBm 1KHz 60%) and adjust RT1 so that the signal is audible .
5	AM(EU,E) Channel 20 Middle volume level Squelch maximum counterclockwise (ASC)	RT401(ASC)	Connect HF generator to jack antenna . Connect sinad meter to jack EXT speaker, adjust the ouput level of HF generator and adjust RT401 to reach at the opening ASC a sinad of $17\text{dB} \pm 2\text{dB}$.

JOHNNY II ASC

BLOC DIAGRAM

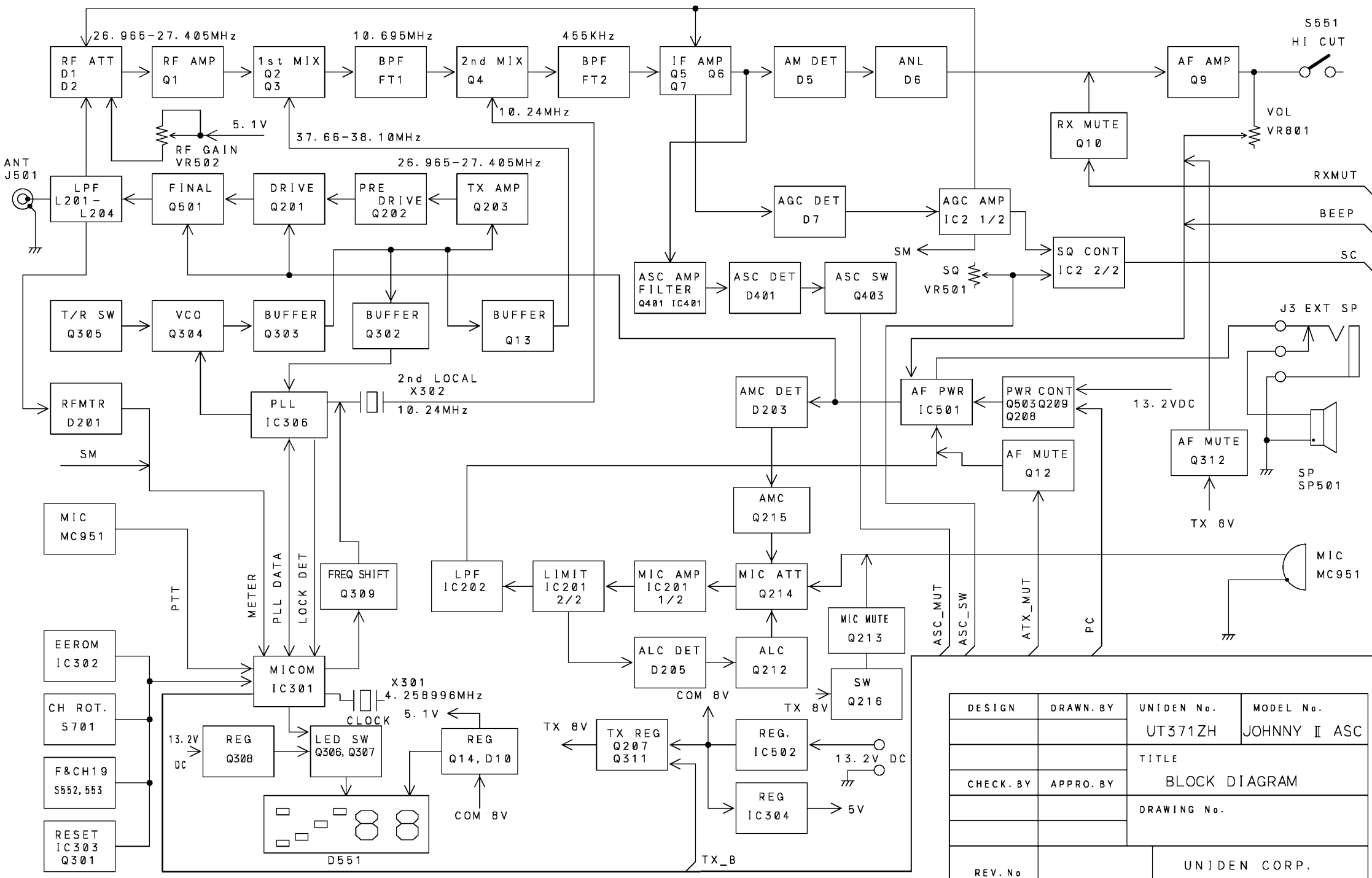

DESIGN	DRAWN BY	UNIDEN No.	MODEL No.
		UT371ZH	JOHNNY II ASC
CHECK BY		APPRO BY	
		TITLE	
		BLOCK DIAGRAM	
		DRAWING No.	
REV. No.		UNIDEN CORP.	

HARRY II Classic

BLOC DIAGRAM

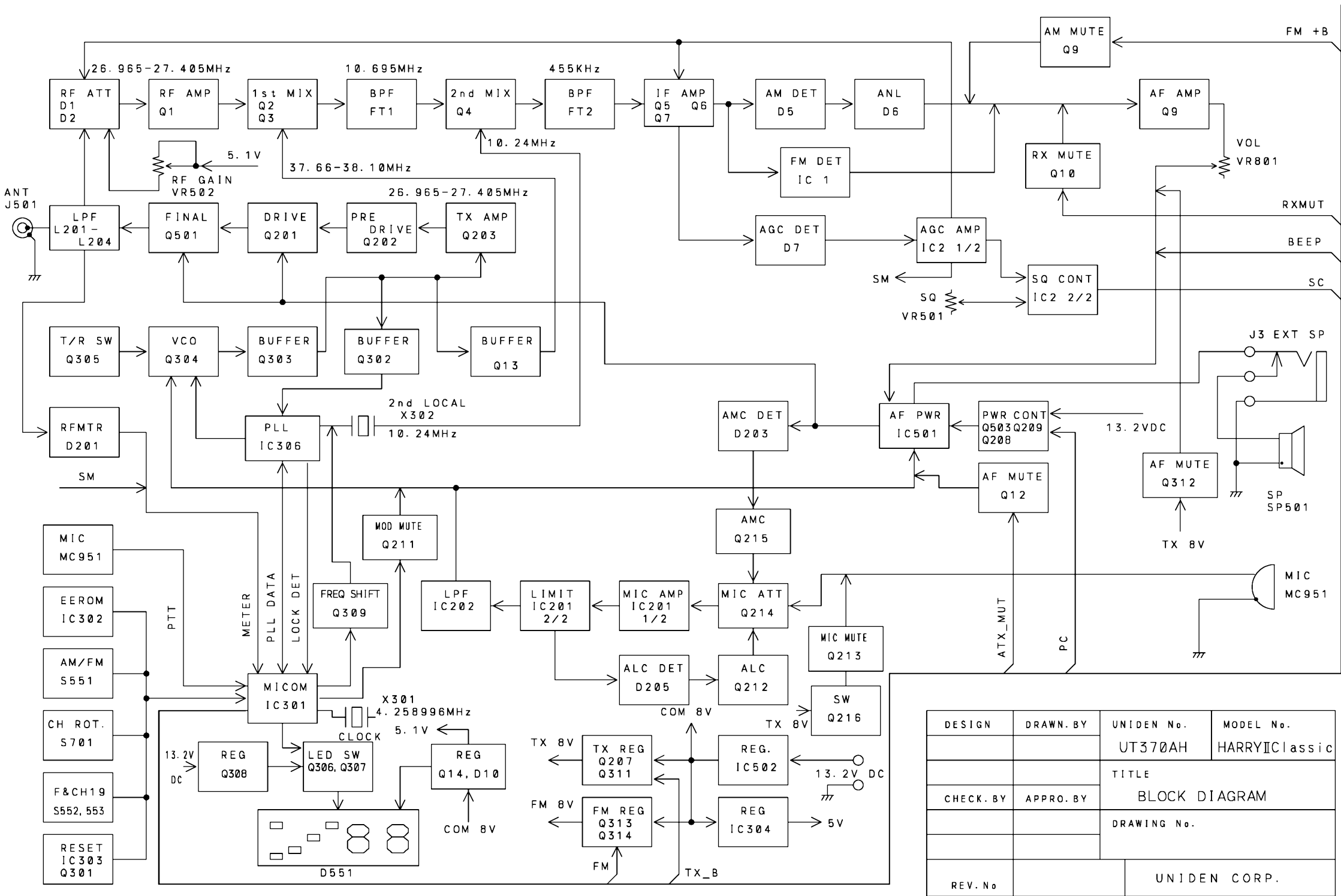

DESIGN	DRAWN BY	UNIDEN No.	MODEL No.
		UT370AH	HARRY II Classic
		TITLE	
CHECK BY	APPRO BY	BLOCK DIAGRAM	
		DRAWING No.	
REV. No		UNIDEN CORP.	

HARRY II ASC

BLOC DIAGRAM

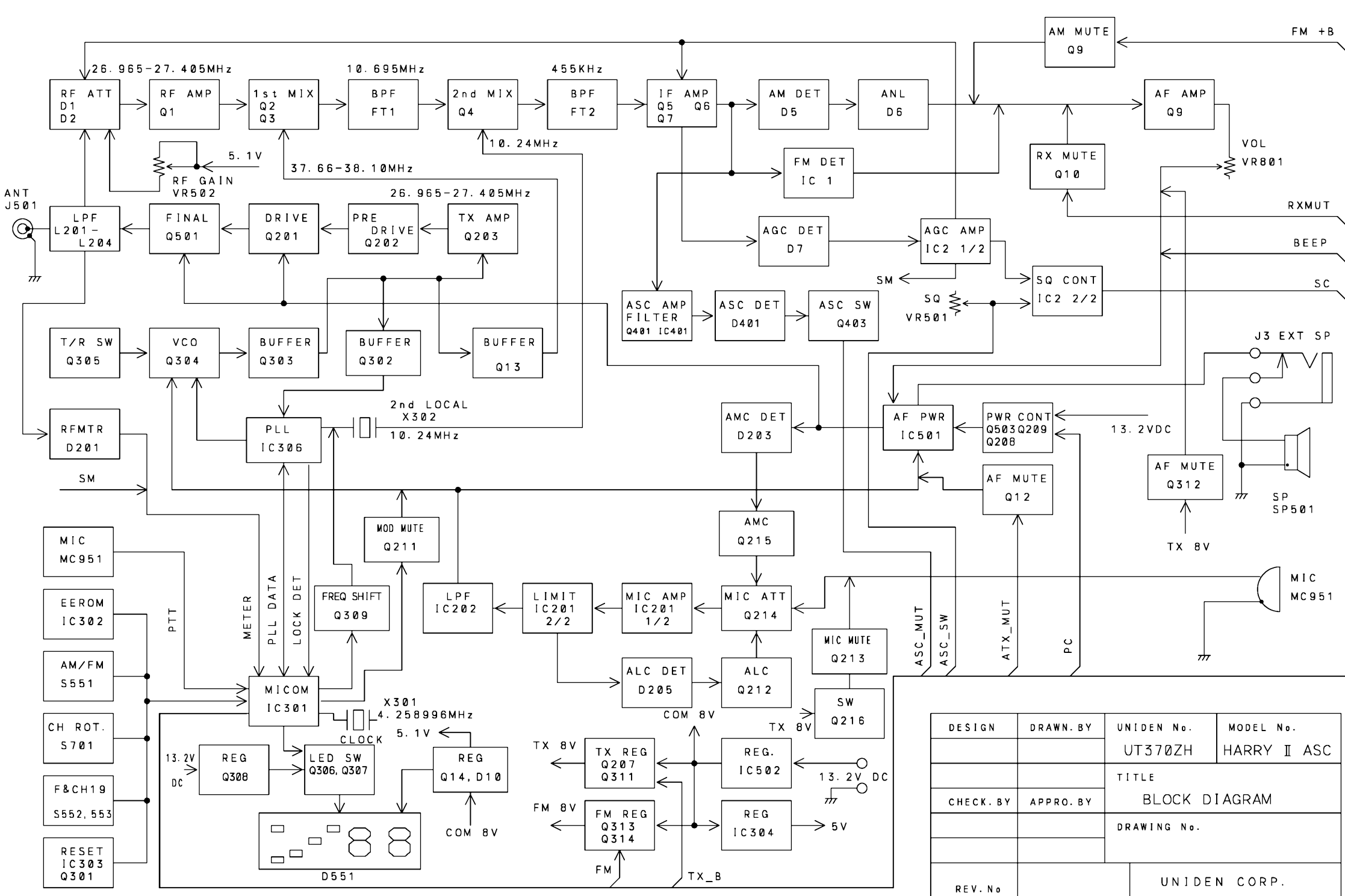

DESIGN	DRAWN BY	UNIDEN No.	MODEL No.
		UT370ZH	HARRY II ASC
CHECK BY		APPRO BY	
		TITLE	
		BLOCK DIAGRAM	
		DRAWING No.	
REV. No.		UNIDEN CORP.	

JOHNNY II ASC

SCHEMATIC DIAGRAM

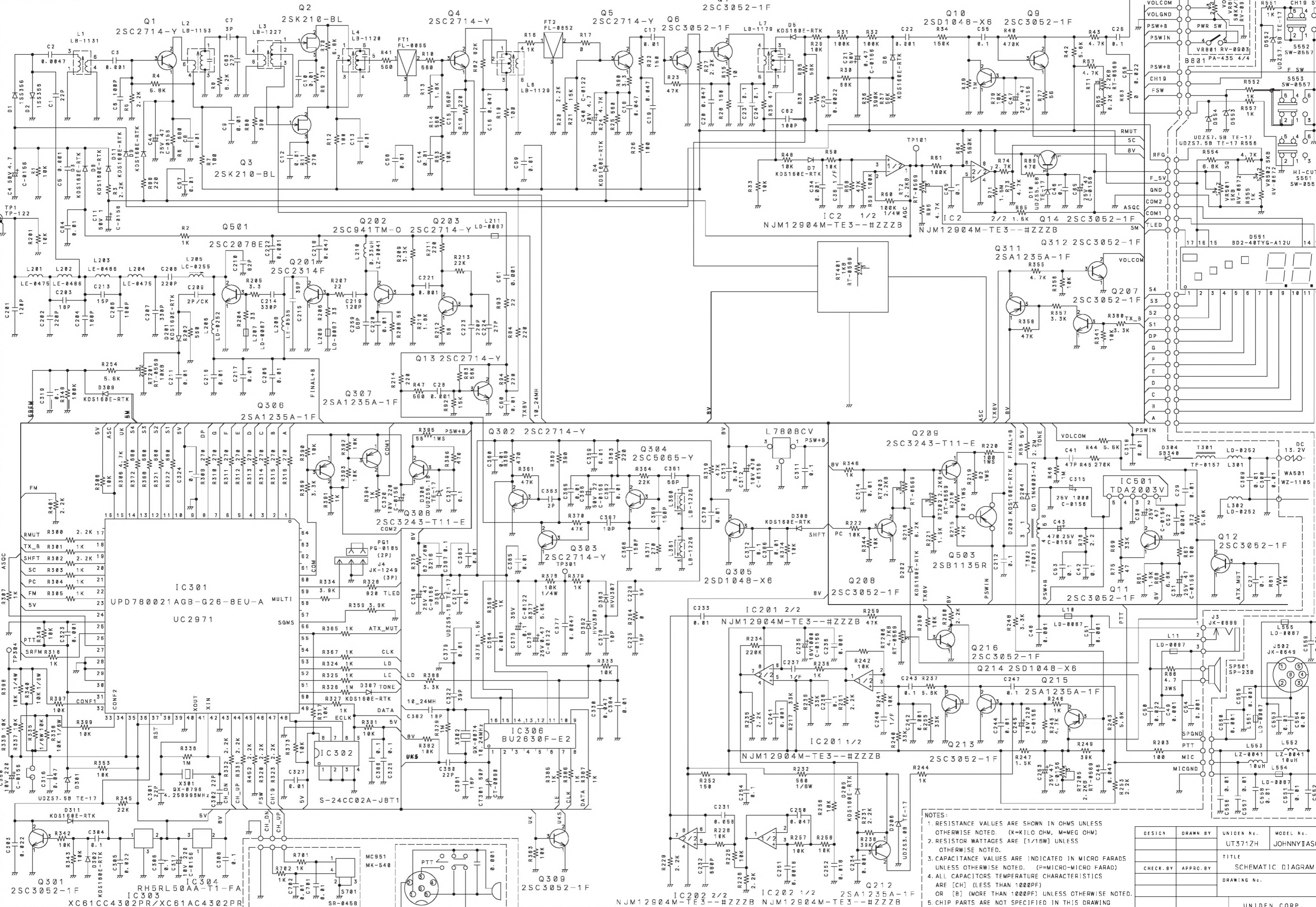

- NOTES:
1. RESISTANCE VALUES ARE SHOWN IN OHMS UNLESS OTHERWISE NOTED. (K=KILO OHM, M=MEG OHM)
 2. RESISTOR WATTAGES ARE [1/8W] UNLESS OTHERWISE NOTED.
 3. CAPACITANCE VALUES ARE INDICATED IN MICRO FARADS UNLESS OTHERWISE NOTED. (P=MICRO-MICRO FARAD)
 4. ALL CAPACITORS TEMPERATURE CHARACTERISTICS ARE [CH] (LESS THAN 100PPF) OR [B] (MORE THAN 100PPF) UNLESS OTHERWISE NOTED.
 5. CHIP PARTS ARE NOT SPECIFIED IN THIS DRAWING PLEASE REFER TO THE PARTS LIST FOR THE CHIP PARTS.

DESIGN	DRAWN BY	UNIDEN No.	MODEL No.
		UT3712H	JOHNNYIASC
TITLE			
SCHEMATIC DIAGRAM			
DRAWING No.			
UNIDEN CORP.			

HARRY II Classic

SCHEMATIC DIAGRAM

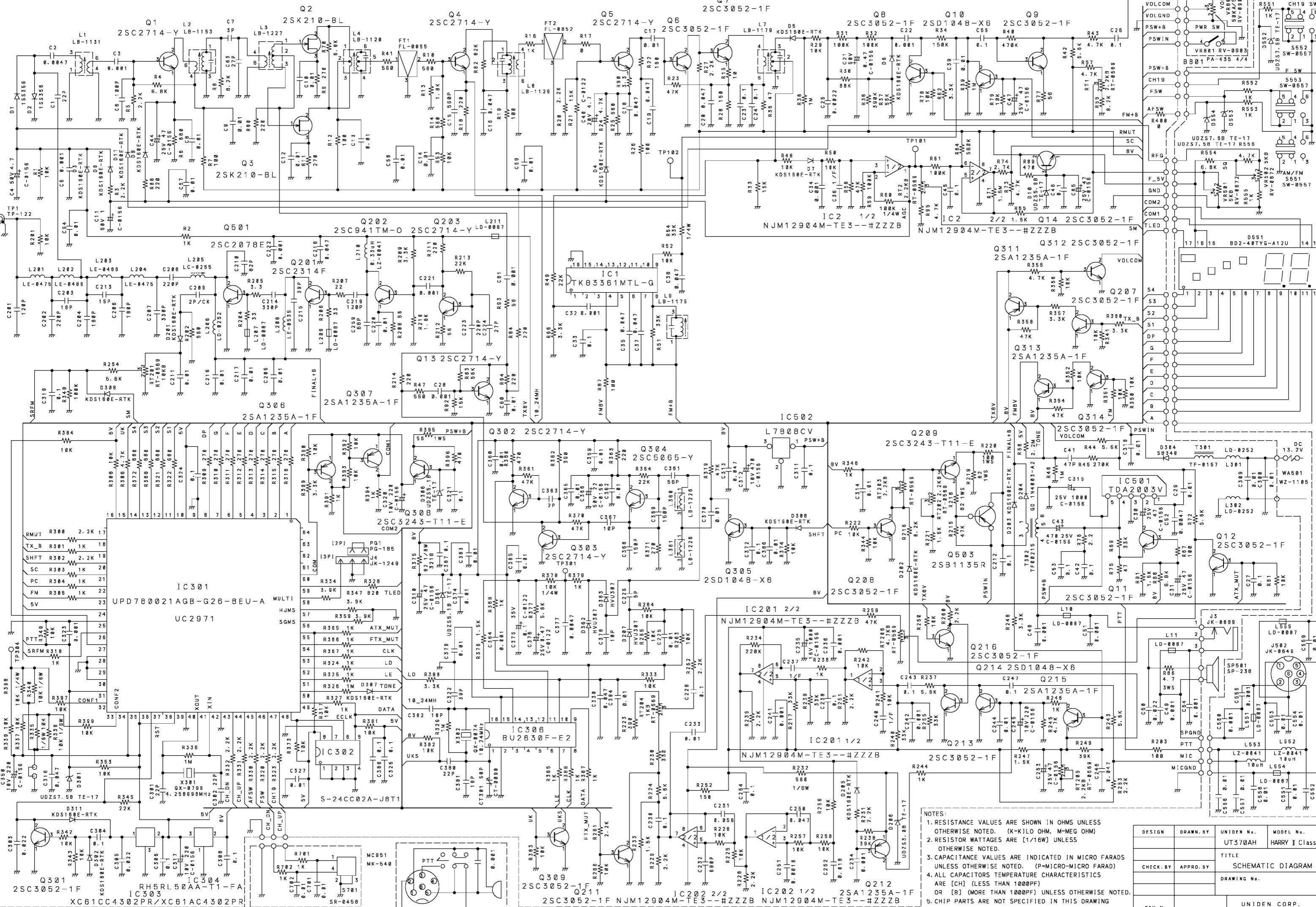

- NOTES:
1. RESISTANCE VALUES ARE SHOWN IN OHMS UNLESS OTHERWISE NOTED. (K=KILO OHM, M=MEG OHM)
 2. RESISTOR WATTAGES ARE [1/16W] UNLESS OTHERWISE NOTED.
 3. CAPACITANCE VALUES ARE INDICATED IN MICRO FARADS UNLESS OTHERWISE NOTED. (P=MICRO-MICRO FARAD) ARE [CH] (LESS THAN 1000PF) OR [B] (MORE THAN 1000PF) UNLESS OTHERWISE NOTED.
 4. ALL CAPACITORS TEMPERATURE CHARACTERISTICS ARE [C] (LESS THAN 1000PF) OR [B] (MORE THAN 1000PF) UNLESS OTHERWISE NOTED.
 5. CHIP PARTS ARE NOT SPECIFIED IN THIS DRAWING PLEASE REFER TO THE PARTS LIST FOR THE CHIP PARTS.

DESIGN	DRAWN BY	UNIDEN No.	MODEL No.
		UT370AH	HARRY I Classic
CHECK BY	APPRO BY	TITLE	
		SCHEMATIC DIAGRAM	
		DRAWING No.	
REV. No		UNIDEN CORP.	

HARRY II ASC

SCHEMATIC DIAGRAM

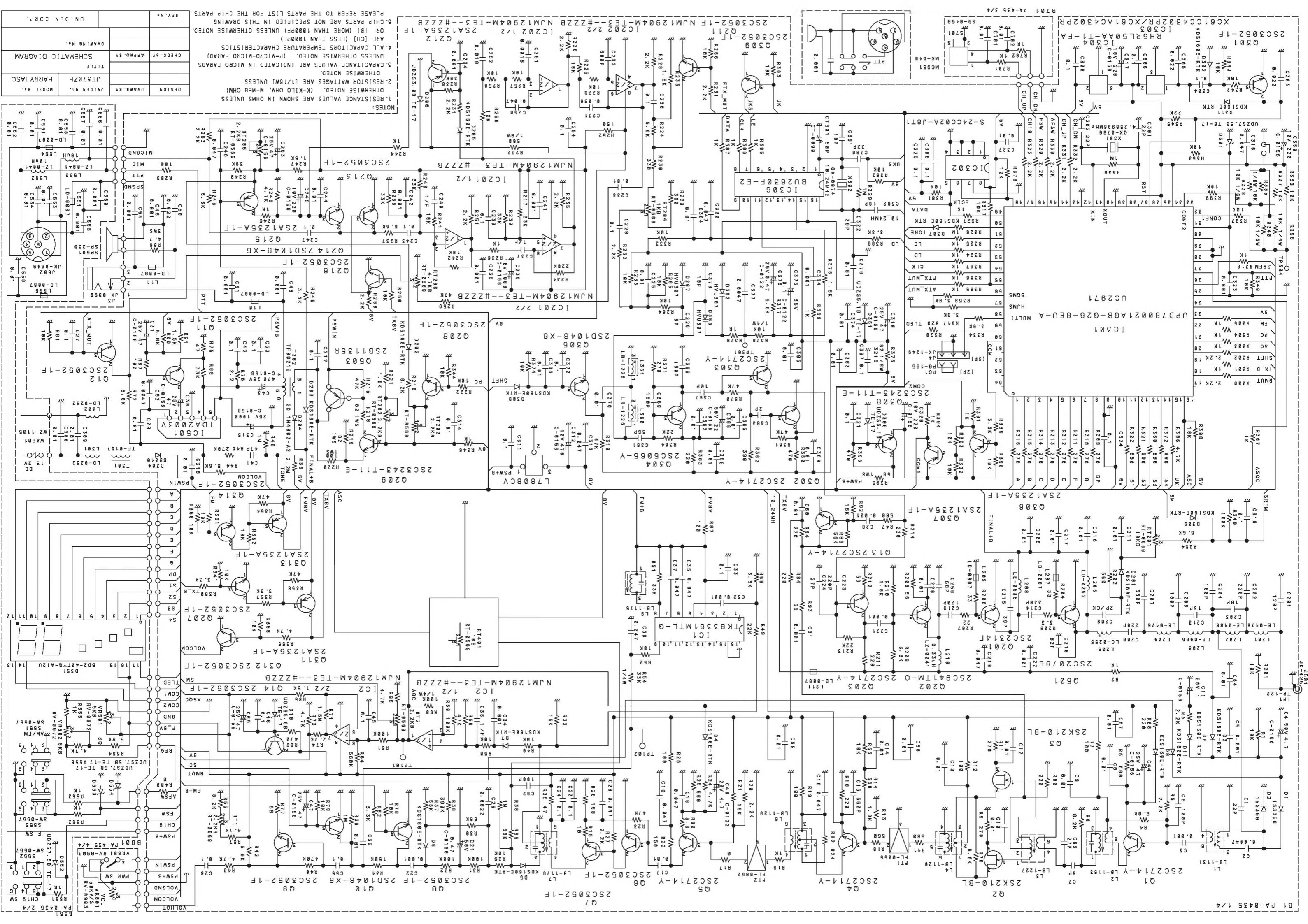

DESIGN	DRWN. BY	HARRYASC
MODEL NO.	UT570ZH	
SCHEMATIC DIAGRAM		
TITLE		
CHECK BY	APPR. BY	
REV. No.		
UNIDEN CORP.		

NOTES:
 1. RESISTANCE VALUES ARE SHOWN IN OHMS UNLESS OTHERWISE NOTED. (K=KILO OHM, M=MEG OHM)
 2. RESISTOR RATINGS ARE [1/4W] UNLESS OTHERWISE NOTED.
 3. CAPACITANCE VALUES ARE INDICATED IN MICRO FARADS, UNLESS OTHERWISE NOTED. (P=PICO-FARAD)
 4. ALL CAPACITORS TEMPERATURE CHARACTERISTICS ARE (CH) (LESS THAN 100PPF) UNLESS OTHERWISE NOTED. OR (B) (MORE THAN 100PPF) UNLESS OTHERWISE NOTED.
 5. CHIPS PARTS ARE NOT SPECIFIED IN THIS DRAWING.
 PLEASE REFER TO THE PARTS LIST FOR THE CHIP PARTS.

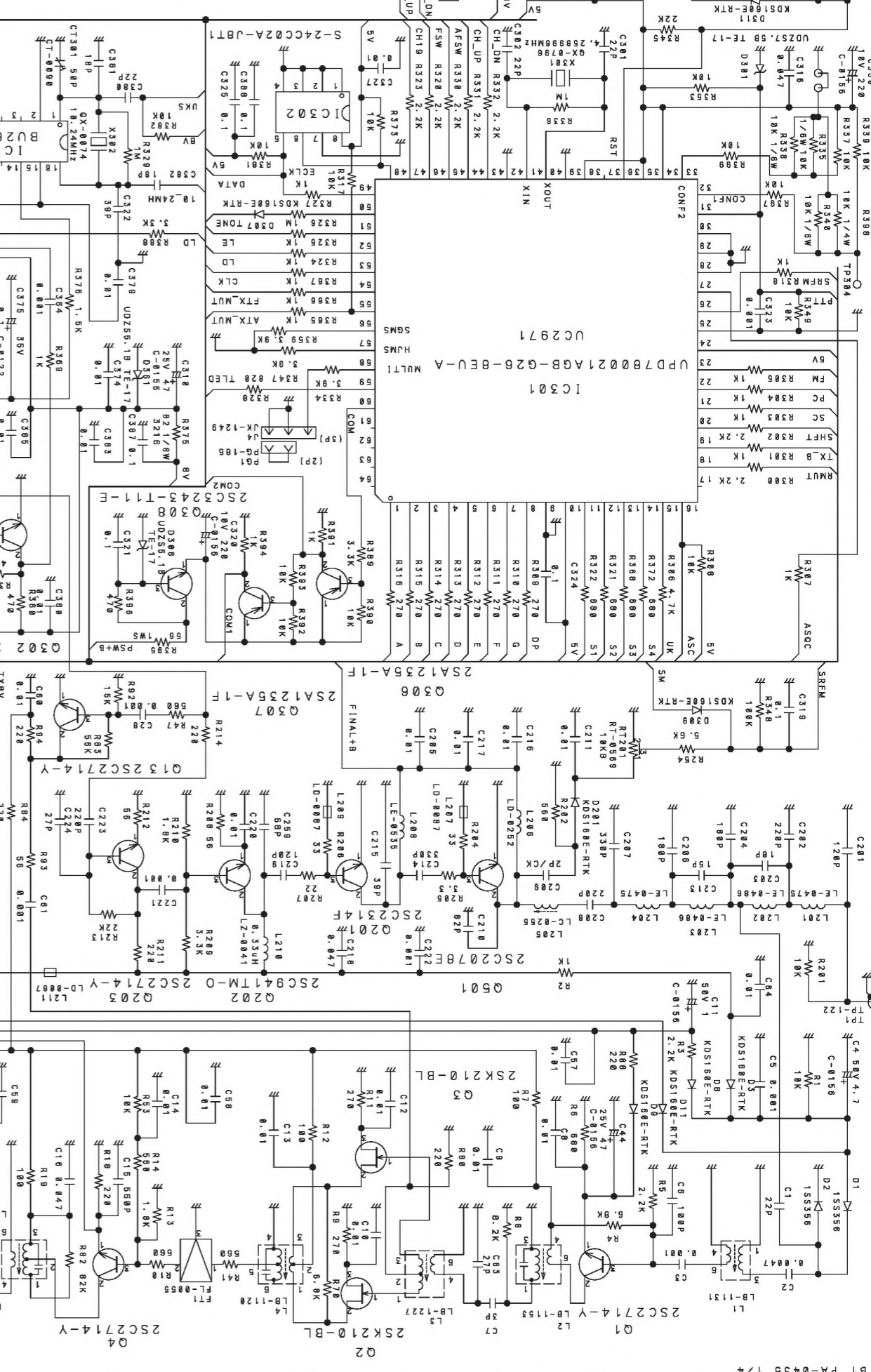
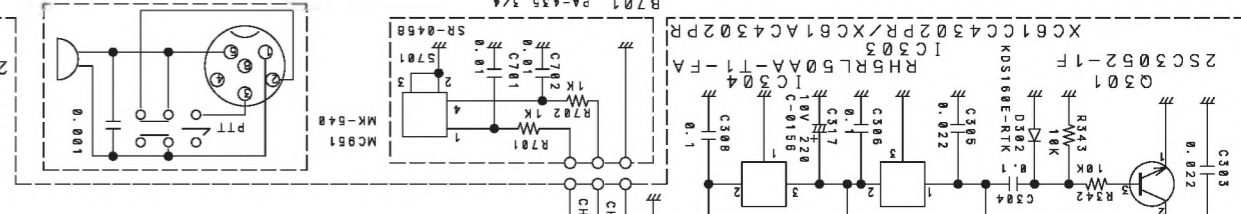
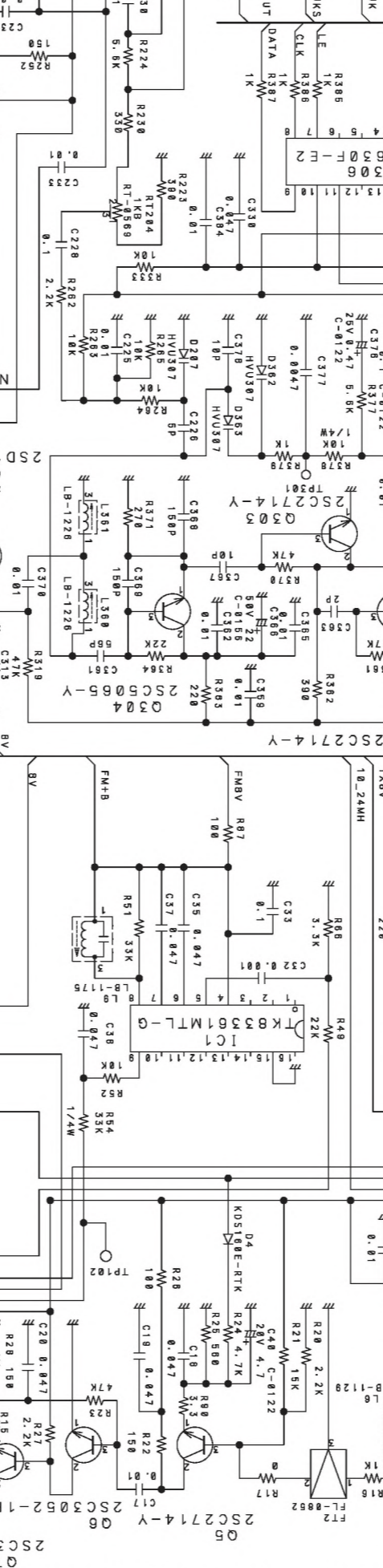
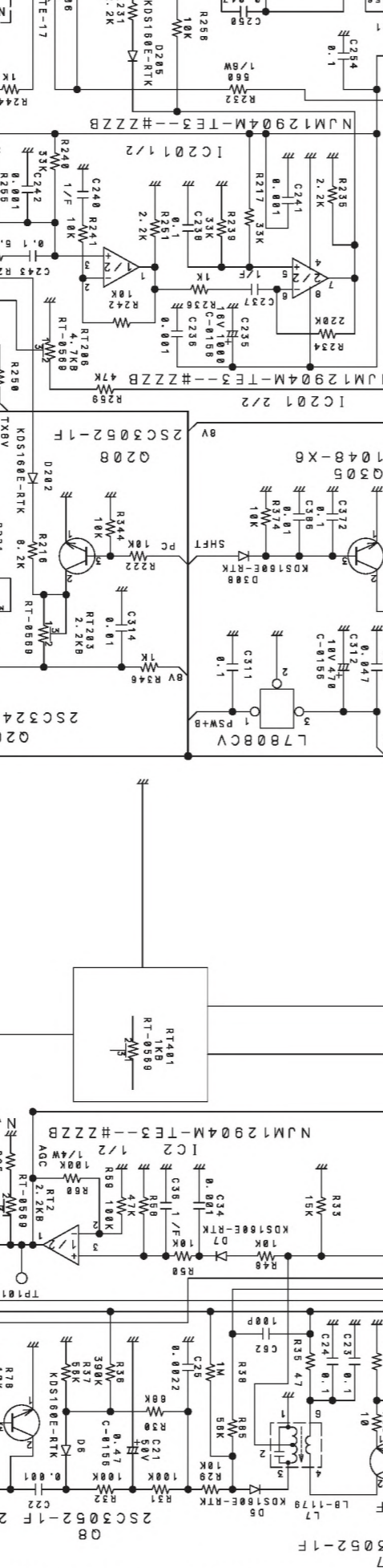
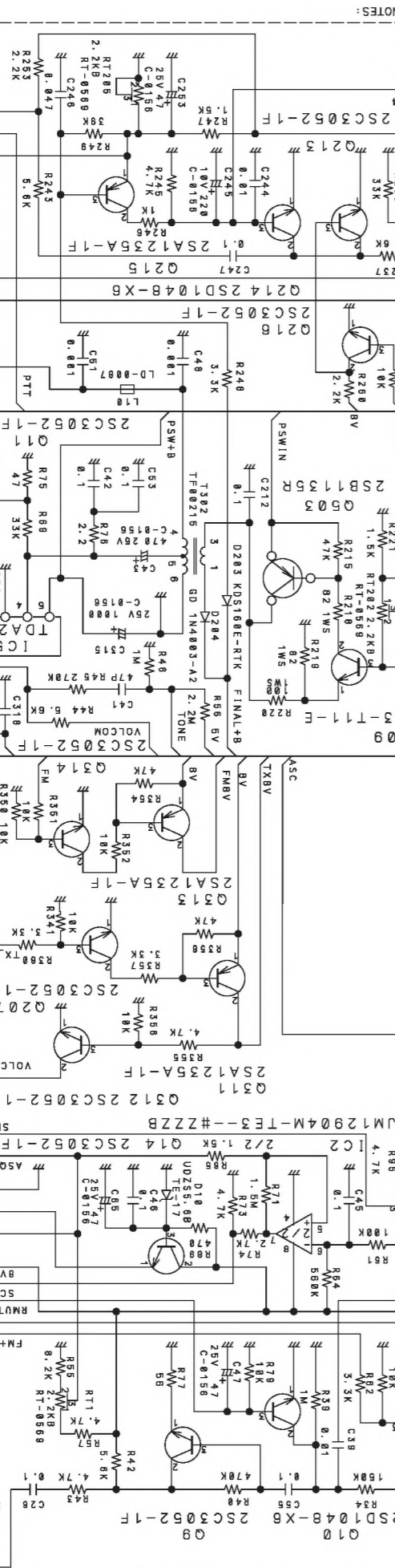
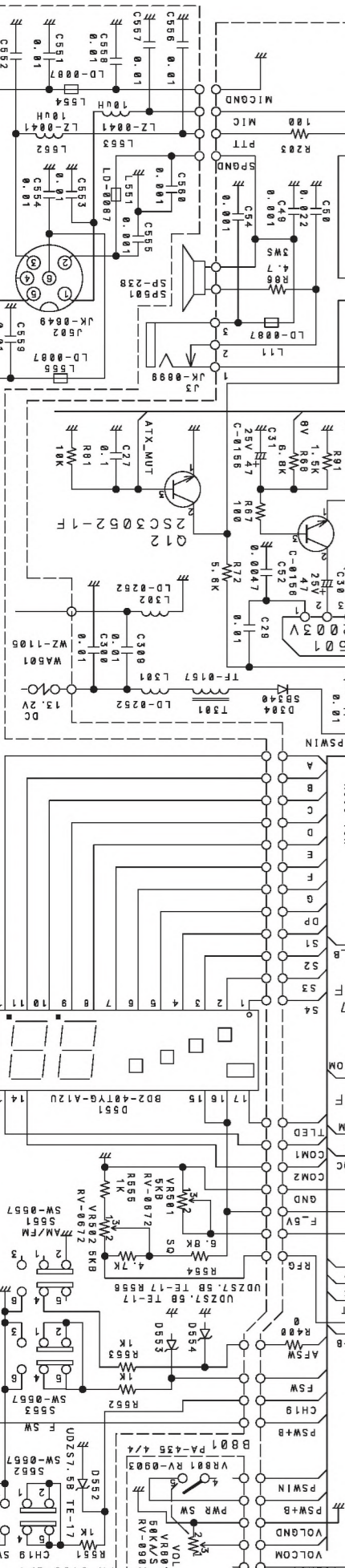

JOHNNY II ASC

COMPONENT LAYOUT

E001: FA-435AA 1/4 (TOP VIEW)

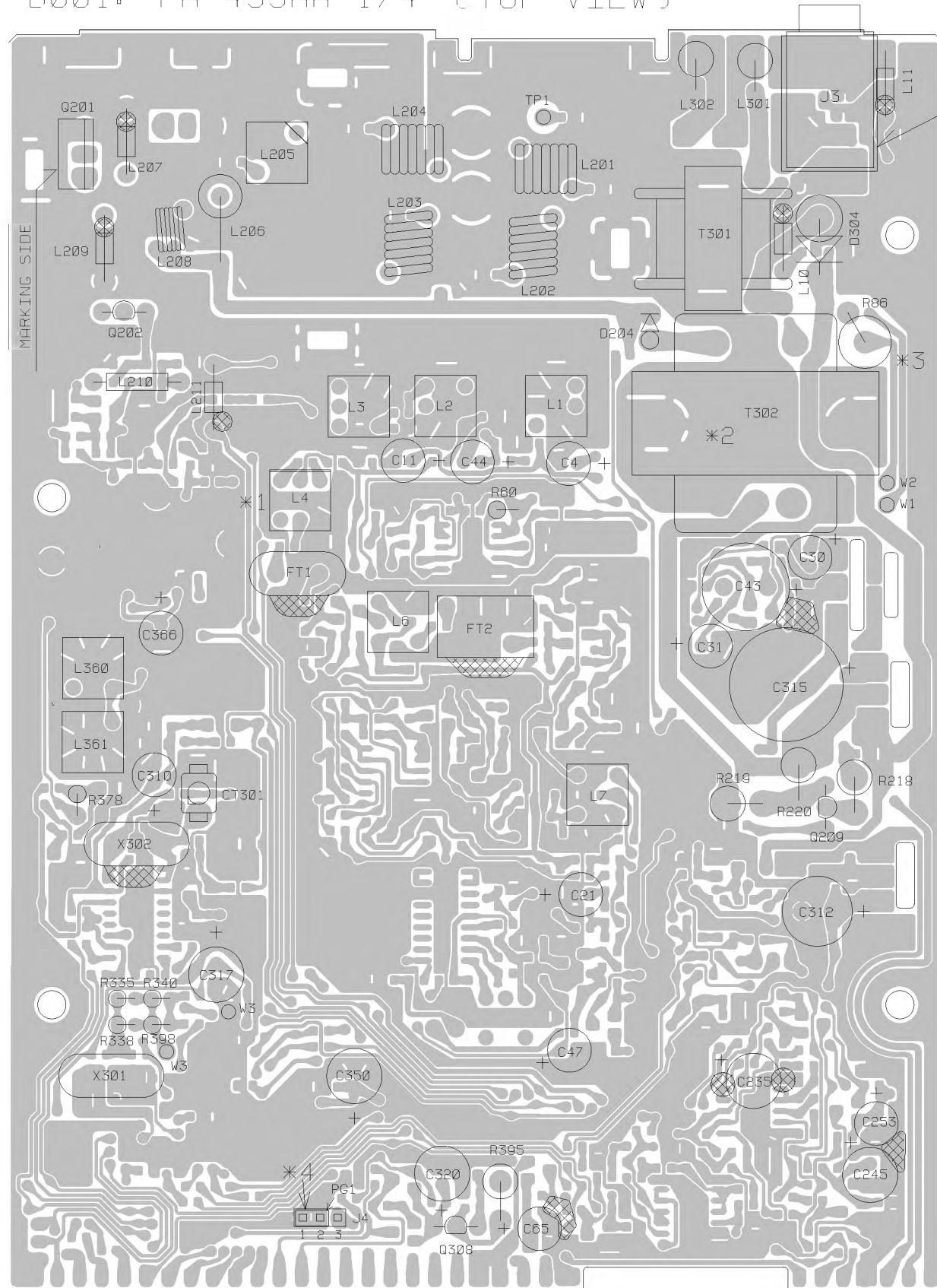

PUT JAPANESE TAPE UNDER J3

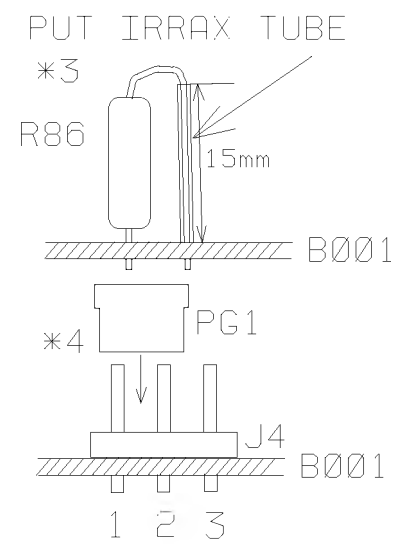
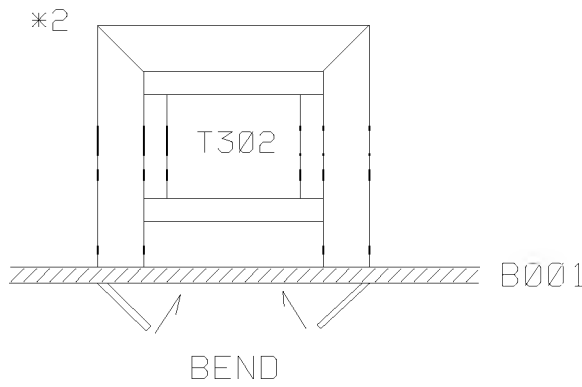
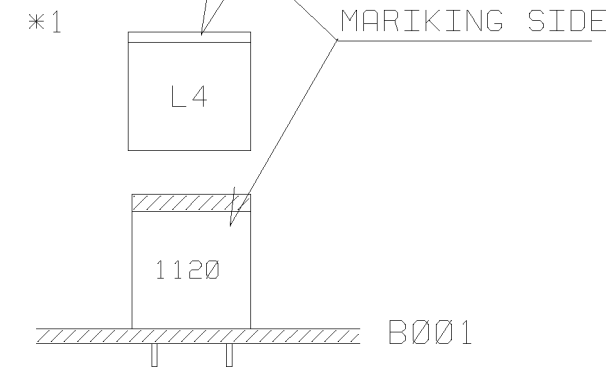

 = YELLOW BOND LOCK (SC-121)

C004	4.7UF 50V	C-0156
C011	1UF 50V	C-0156
C021	0.47UF 50V	C-0156
C030	47UF 25V	C-0156
C031	47UF 25V	C-0156
C043	470UF 25V	C-0156
C044	47UF 25V	C-0156
C047	47UF 25V	C-0156
C065	47UF 25V	C-0156
C235	1000UF 16V	C-0156
C245	220UF 10V	C-0156
C253	47UF 25V	C-0156
C310	47UF 25V	C-0156
C312	470UF 10V	C-0156
C315	1000UF 25V	C-0156
C317	220UF 10V	C-0156
C320	220UF 10V	C-0156
C350	220UF 10V	C-0156
C366	22UF 50V	C-0156
CT301	CT-090 ECR-LA050M52	50PF
D204	GD 1N4003-A2	
D304	SB340	
FT001	FL-055 10M07AZ	
FT002	FL-852 LTS455HTW	
J003	JK-899 JH3501-0200	
J004	JK-1249 IMSA-9210B-1-0320	
L001	LB-1131 KS2484F	
L002	LB-1153 KS2485NC	
L003	LB-1227 KS2553N	
L004	LB-1120 KS2482AC	
L006	LB-1129 7PL4A151N	
L007	LB-1179 7MK4A033N	
L010	LD-087 BF04-3*5*1	
L011	LD-087 BF04-3*5*1	
L201	LE-475 AC1979	
L202	LE-486 AC1973	
L203	LE-486 AC1973	
L204	LE-475 AC1979	
L205	LC-255 MD146-08F42	
L206	LD-252 3A1737RH	
L207	LD-087 BF04-3*5*1	
L208	LE-535	
L209	LD-087 BF04-3*5*1	
L210	LZ-041 0.33UH	
L211	LD-087 BF04-3*5*1	
L301	LD-252 3A1737RH	
L302	LD-252 3A1737RH	
L360	LB-1226 KY1107R	
L361	LB-1226 KY1107R	
PG001	PG-185 IMSA-9215H-T	
Q201	OB-792 2SC2314F	
Q202	OB-301 2SC941TM-0	
Q209	OB-867 2SC3243-T11-E	
Q308	OB-867 2SC3243-T11-E	
R060	100K 1/4W	
R086	4.7 3WS	
R218	82 1WS	
R219	82 1WS	
R220	100 1WS	
R335	10K 1/6W	
R338	10K 1/6W	
R340	10K 1/6W	
R378	10K 1/4W	
R395	56 1WS	
R398	10K 1/4W	
T301	TF-157	
T302	TF-215	
TP001	TP-122 1820-01-PP1	
W001	UL1007 #24 10-140-3 GRY	
W002	UL1007 #24 10-140-3 WHT	
W003	UL1571 #26 5-30-5 WHT	
X301	OX-796 4.258996MHz	
X302	OX-074 10.240MHz	

R378	10K 1/4W
R395	56 1WS
R398	10K 1/4W
T301	TF-157
T302	TF-215
TP001	TP-122 1820-01-PP1
W001	UL1007 #24 10-140-3 GRY
W002	UL1007 #24 10-140-3 WHT
W003	UL1571 #26 5-30-5 WHT
X301	OX-796 4.258996MHz
X302	OX-074 10.240MHz

REV. CODE	△	△	△	△	△	△	△	△	△	△	△	△	△	△	△	△	△	△	△	△	△	△	△
DATE																							
LOT#/RN#																							
REVISD BY																							
CHECKED BY																							

NOTES:

- RESISTANCE VALUES ARE SHOWN IN OHMS UNLESS OTHERWISE NOTED. (K=KILO OHM, M=MEG OHM)
- CAPACITANCE VALUES ARE INDICATED IN MICRO FARADS UNLESS OTHERWISE NOTED.

DESIGN. BY	DRAWN. BY	UNIDEN NO.	MODEL NO.
		UT3712H	JOHNNY I I ASC
		TITLE MAIN PCB	
CHECK. BY	APPRO. BY	PARTS ASS'Y TOP VIEW	
		DRAWING NO.	
REV. NO.		UNIDEN CORP.	

B001: PA-435AA 1/4 (TOP VIEW)

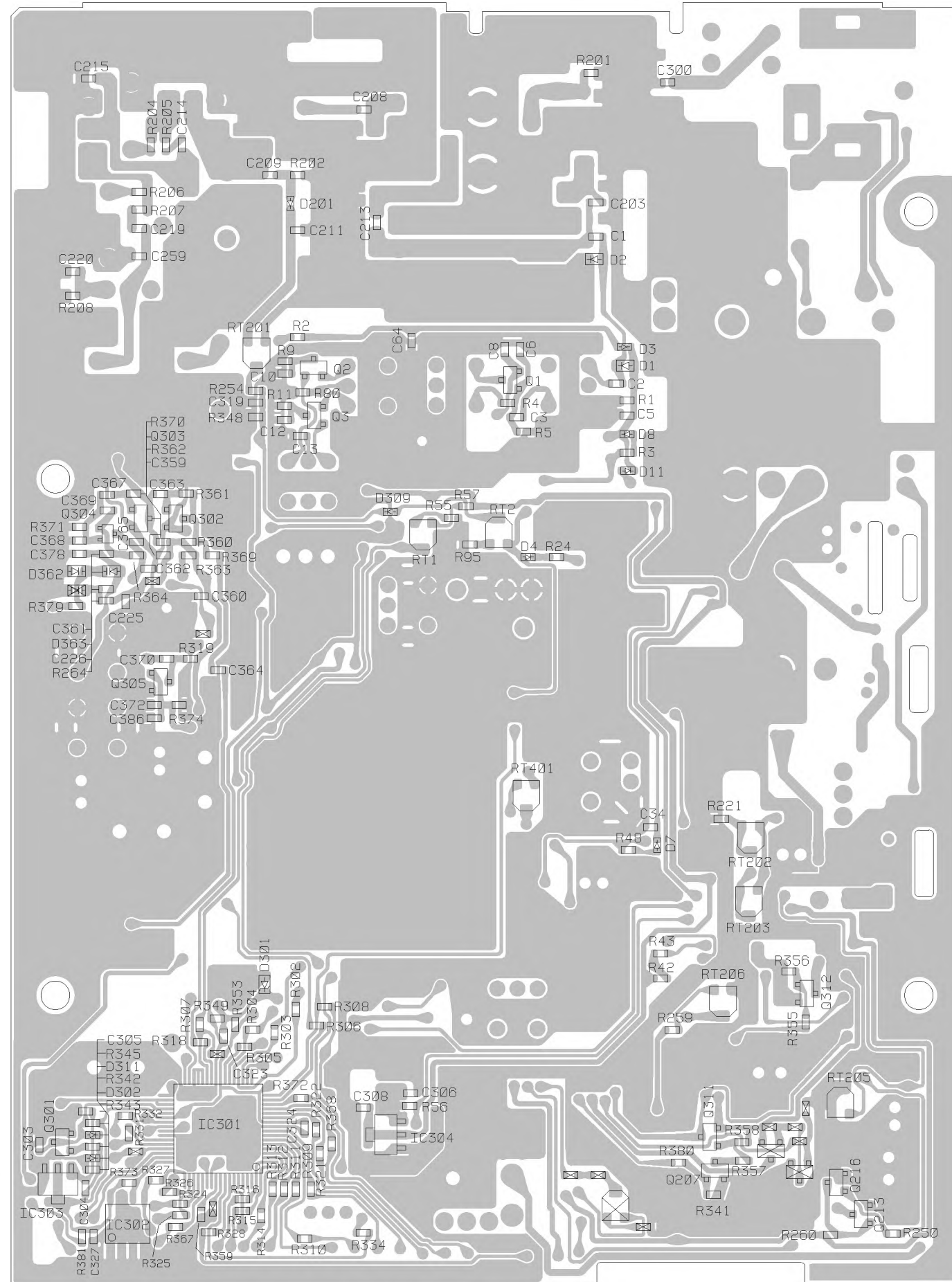

REVISIONS	REV. CODE																						
	DATE																						
	LOT#/RN#																						
	REVISED BY																						
	CHECKED BY																						

DESIGN. BY	DRAWN. BY	UNIDEN NO.	MODEL NO.
		UT371ZH	JOHNNY II ASC
CHECK. BY	APPRO. BY	TITLE MAIN PCB 1/2 CHIP LAYOUT TOP VIEW	
		DRAWING NO.	
REV. NO.		UNIDEN CORP.	

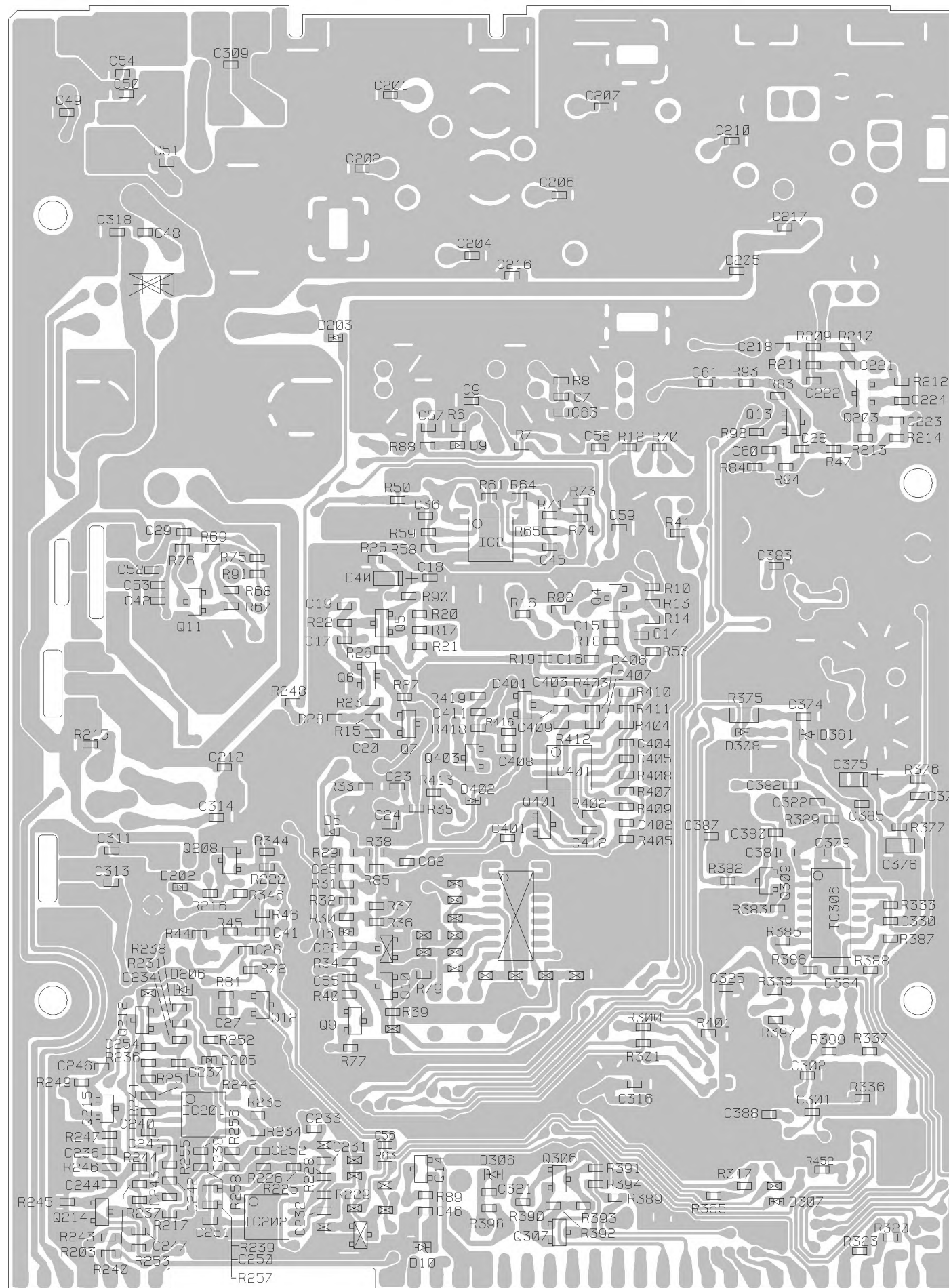

REVISIONS	REV. CODE	△	△	△	△	△	△	△	△	△	△	△	△	△	△	△	△	△	△	△
	DATE																			
	LOT#/RN#																			
	REVISED BY																			
	CHECKED BY																			

DESIGN. BY	DRAWN. BY	UNIDEN NO.	MODEL NO.
		UT371ZH	JOHNNY II ASC
CHECK. BY	APPRO. BY	TITLE	MAIN PCB 1/2
			CHIP LAYOUT BOTTOM VIEW
		DRAWING NO.	
REV. NO.		UNIDEN CORP.	

B701: PA-435AA 3/4

(BOTTOM VIEW)

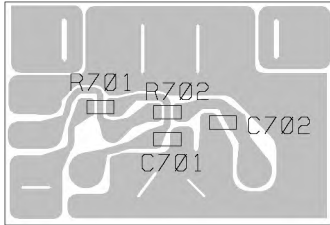

C701	0.01
C702	0.01
R701	1K
R702	1K

NOTES:

1. RESISTANCE VALUES ARE SHOWN IN OHMS UNLESS OTHERWISE NOTED.
(K=KILO OHM. M=MEG OHM)
2. RESISTOR WATTAGES ARE 1/16W UNLESS OTHERWISE NOTED.
3. CAPACITANCE VALUES ARE INDICATED IN MICRO FARADS UNLESS OTHERWISE NOTED.
4. ALL CAPACITORS TEMPERATURE CHARACTERISTICS ARE B UNLESS OTHERWISE NOTED.

REVISIONS	REV. CODE	△	△	△	△	△	△	△	△	△	△	△	△	△	△	△	△	△	△
	DATE																		
	LOT#/RN#																		
	REVISIED BY																		
	CHECKED BY																		

DESIGN. BY	DRAWN. BY	UNIDEN NO. UT371ZH	MODEL NO. JOHNNY II ASC
		TITLE SW PCB	
CHECK. BY	APPRO. BY	CHIP LAYOUT BOTTOM VIEW	
		DRAWING NO.	
REV. NO.		UNIDEN CORP.	

REVISIONS	REV. CODE	△	△	△	△	△	△	△	△	△	△	△	△	△	△
	DATE														
	LOT#/RN#														
	REVISED BY														
	CHECKED BY														

⊘ : SOLDERING

* APPLY THERMAL COMPOUND

Y501, 502: BOTH SIDE
 IC501, 502, Q503 : REAR SIDE
 HEAT SINK(HHSK4B9767Z) : REAR SIDE(CHASSIS SIDE)

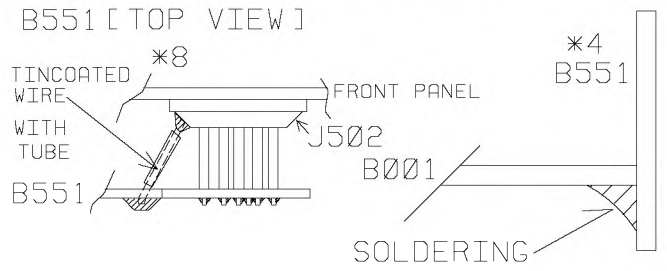
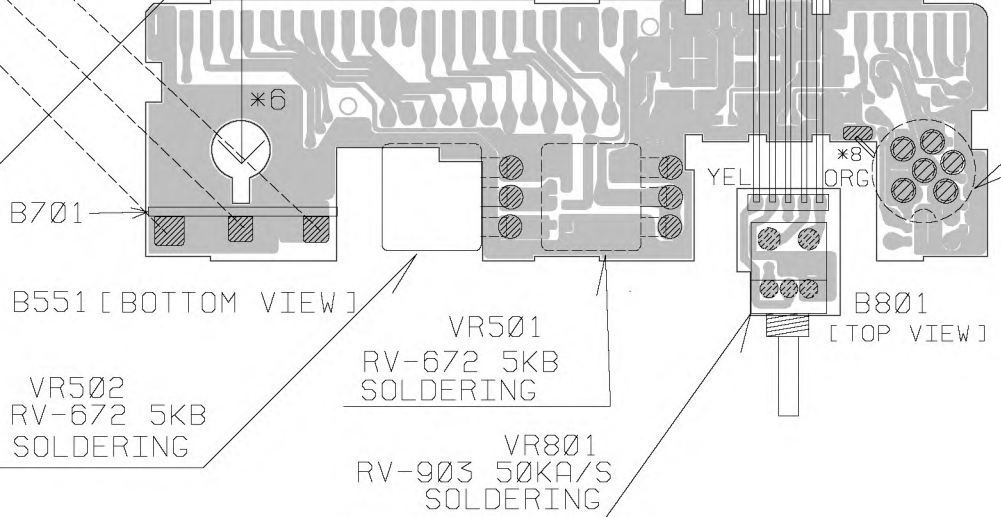
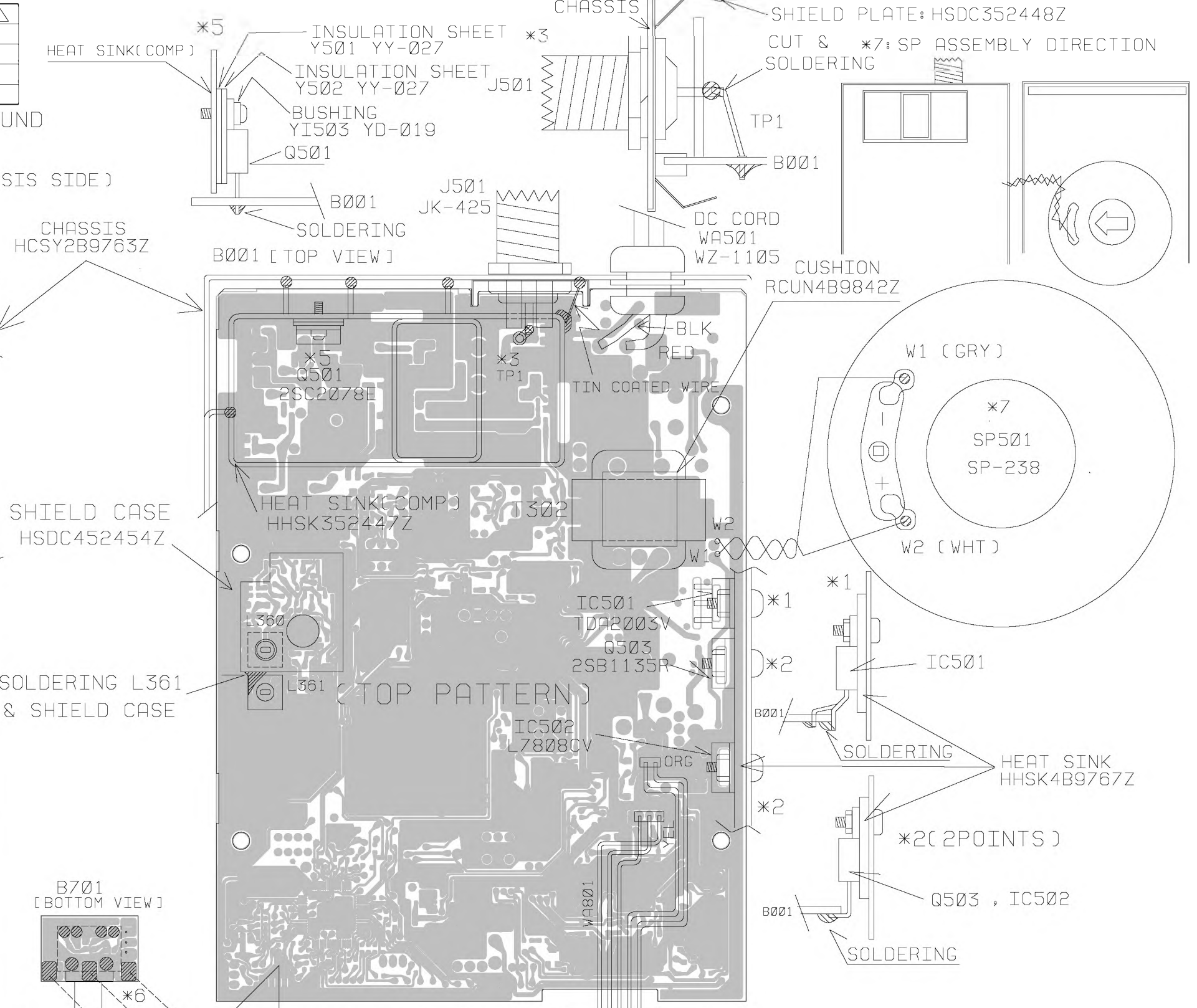
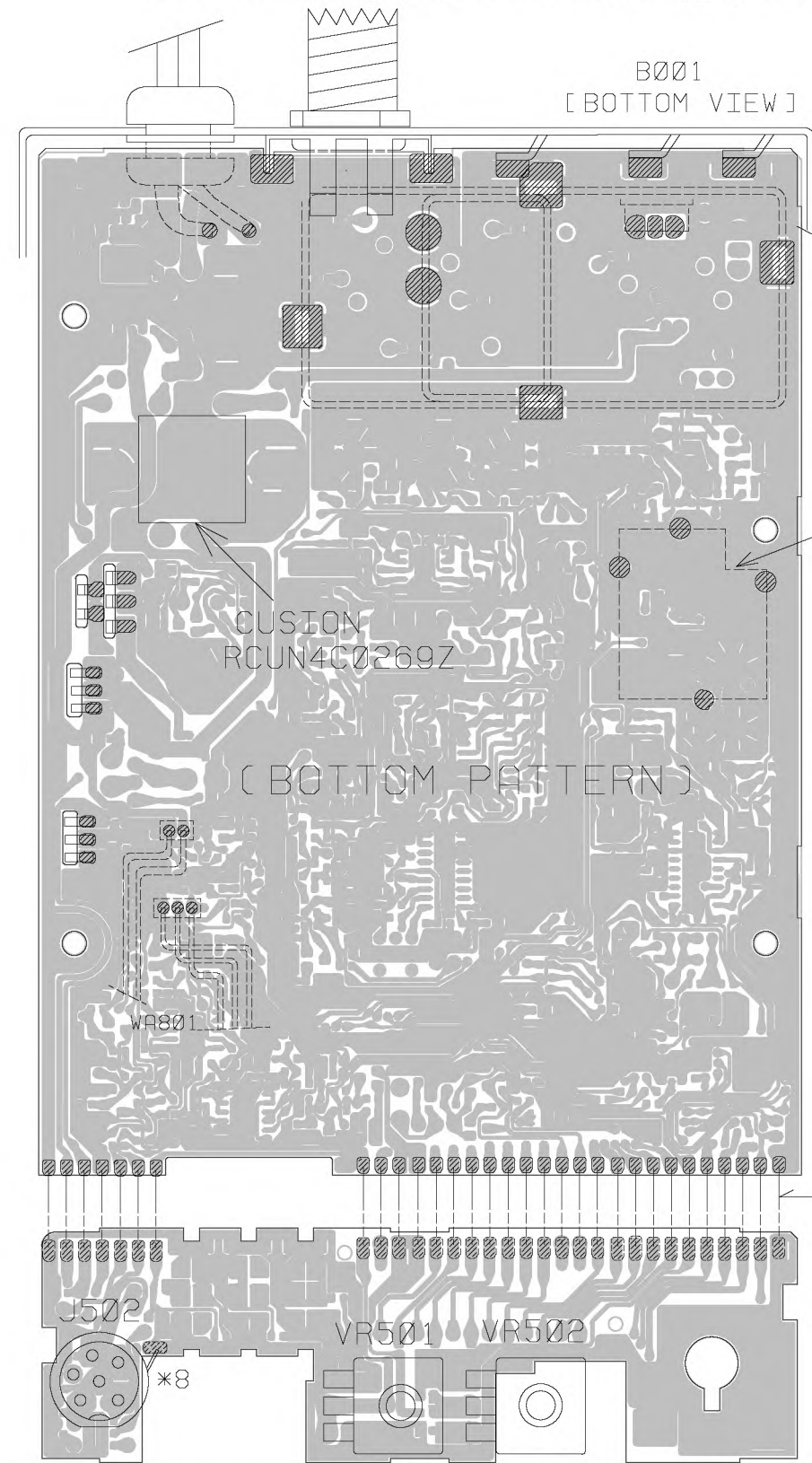

DESIGN. BY	DRAWN. BY	UNIDEN NO.	MODEL NO.
		UT371ZH	JOHNNY II ASC
CHECK. BY	APPRO. BY	TITLE	
		WIRING DIAGRAM	
		DRAWING NO.	
REV. NO.		UNIDEN CORP.	

HARRY II Classic

COMPONENT LAYOUT

REVISIONS	REV. CODE	△	△	△	△	△	△	△	△	△	△	△	△	△
	DATE													
	LOT#/RN#													
	REVISED BY													
	CHECKED BY													

 : SOLDERING
 * APPLY THERMAL COMPOUND
 Y501, 502: BOTH SIDE
 IC501, 502, Q503 : REAR SIDE
 HEAT SINK(HHSK4B9767Z) : REAR SIDE(CHASSIS SIDE)

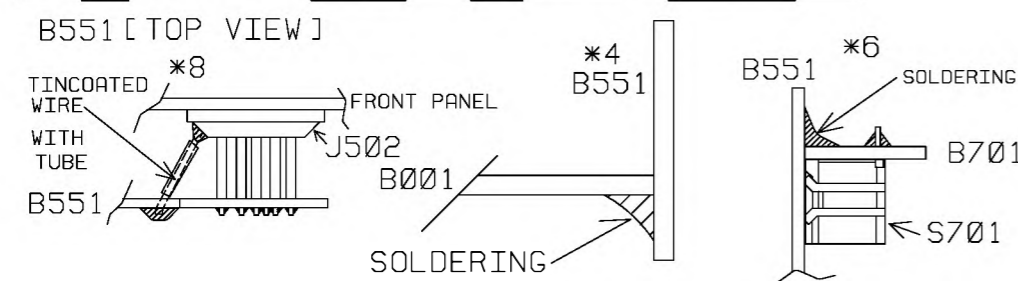
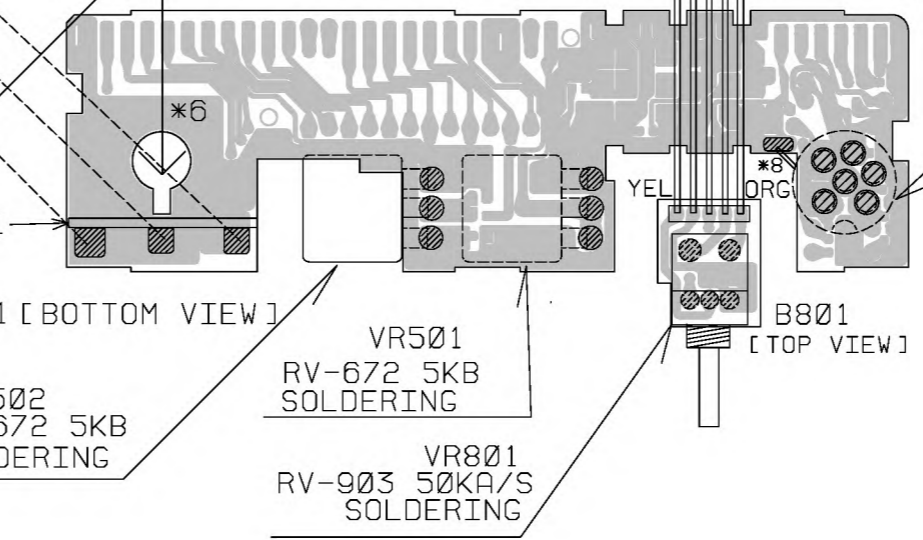
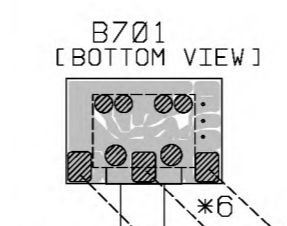
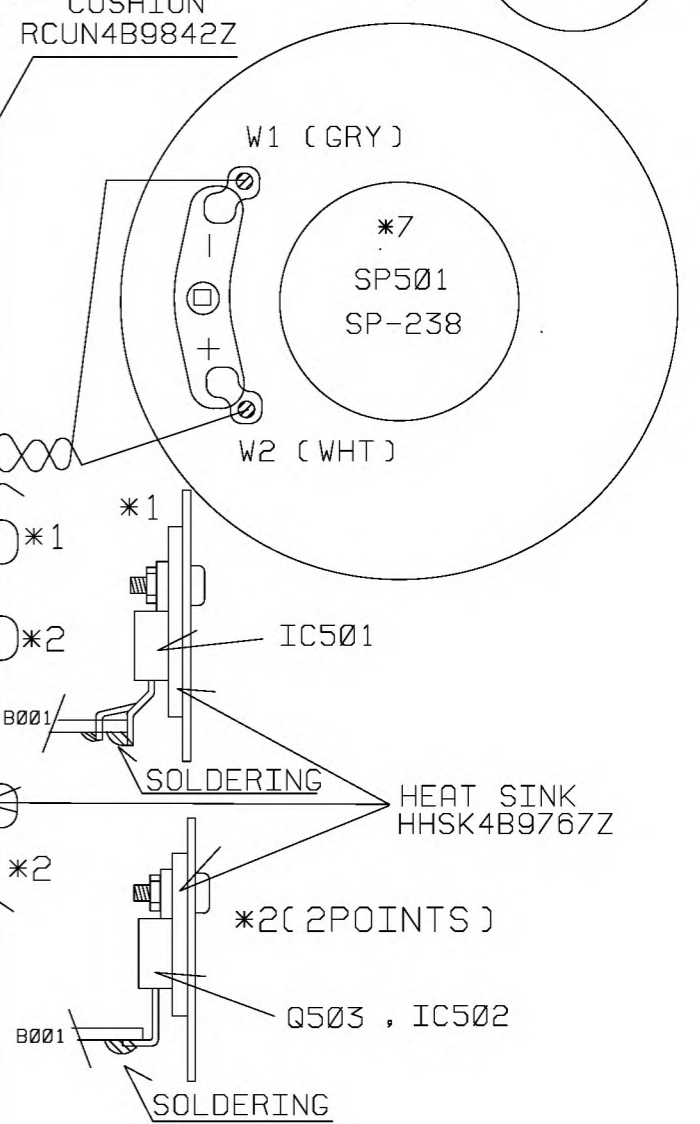
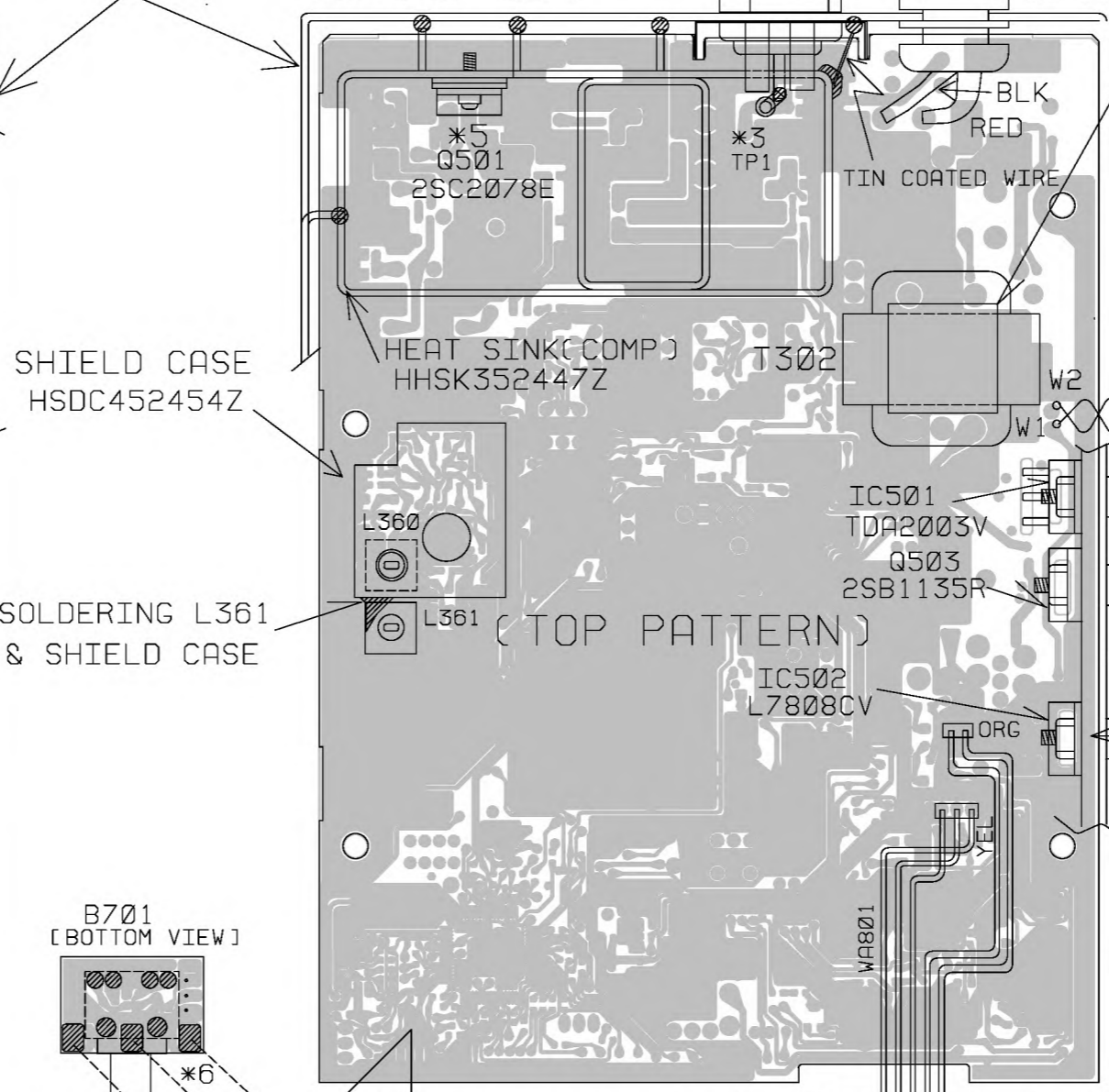
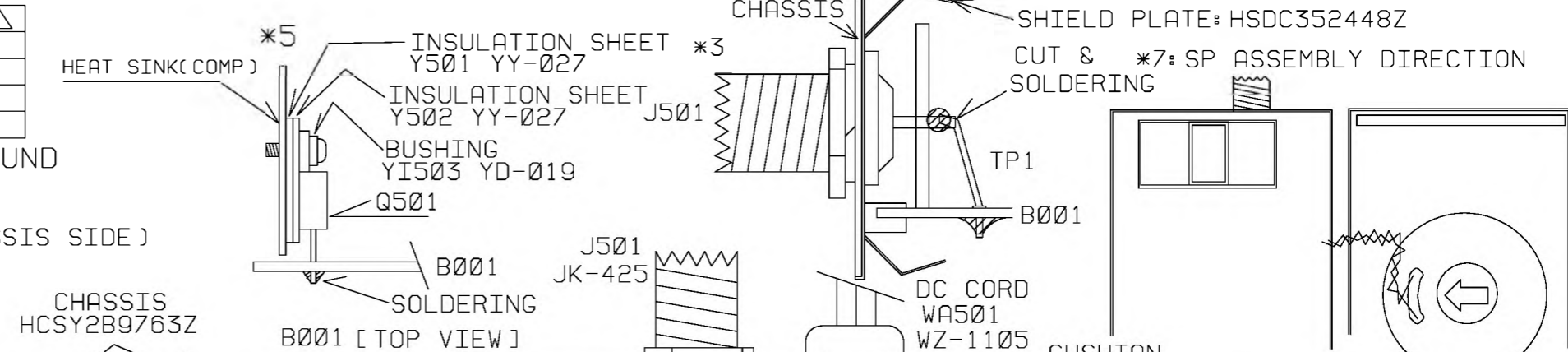
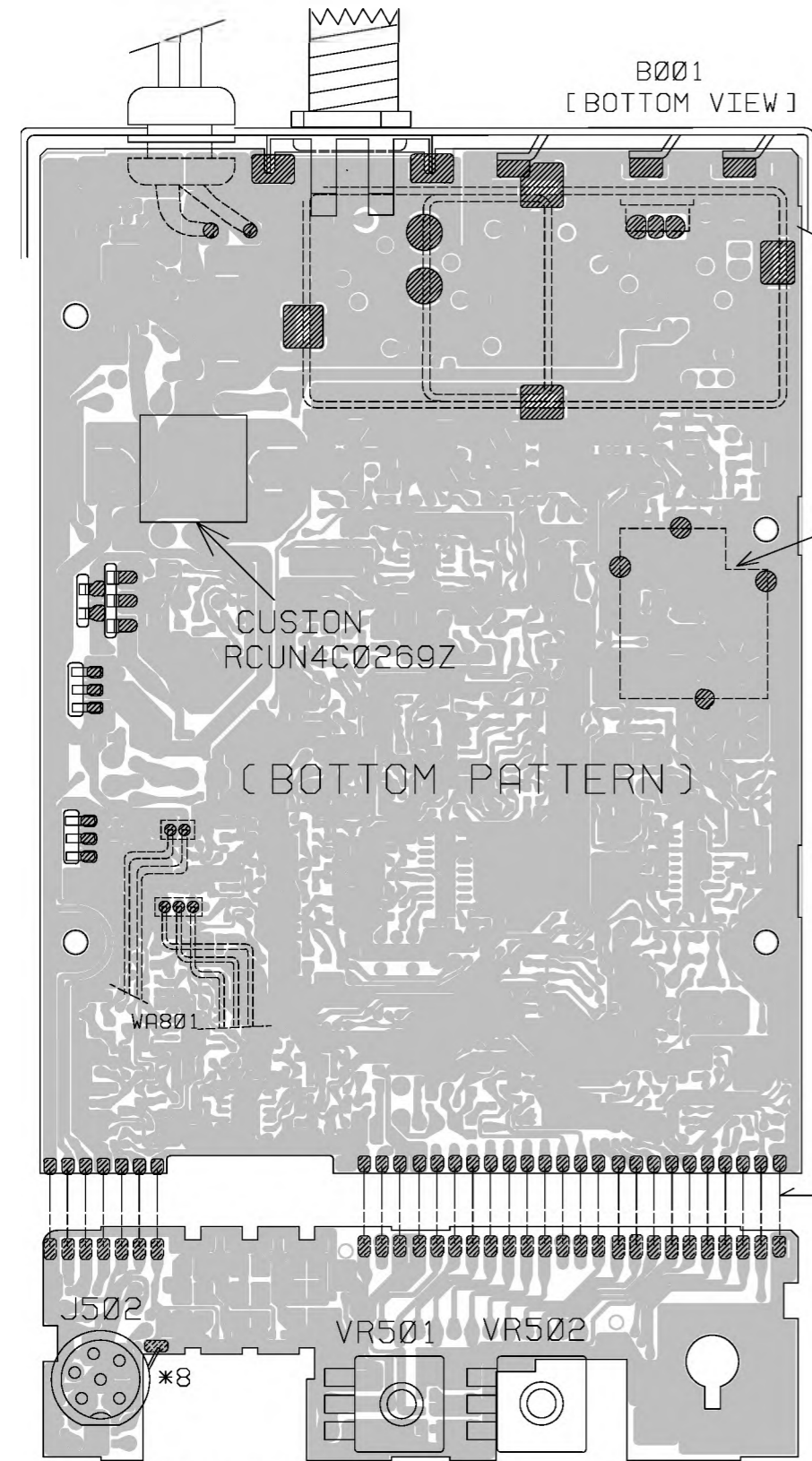

DESIGN. BY	DRAWN. BY	UNIDEN NO.	MODEL NO.
		UT370AH	HARRY II Classic
CHECK. BY	APPRO. BY	TITLE	
		WIRING DIAGRAM	
		DRAWING NO.	
REV. NO.		UNIDEN CORP.	

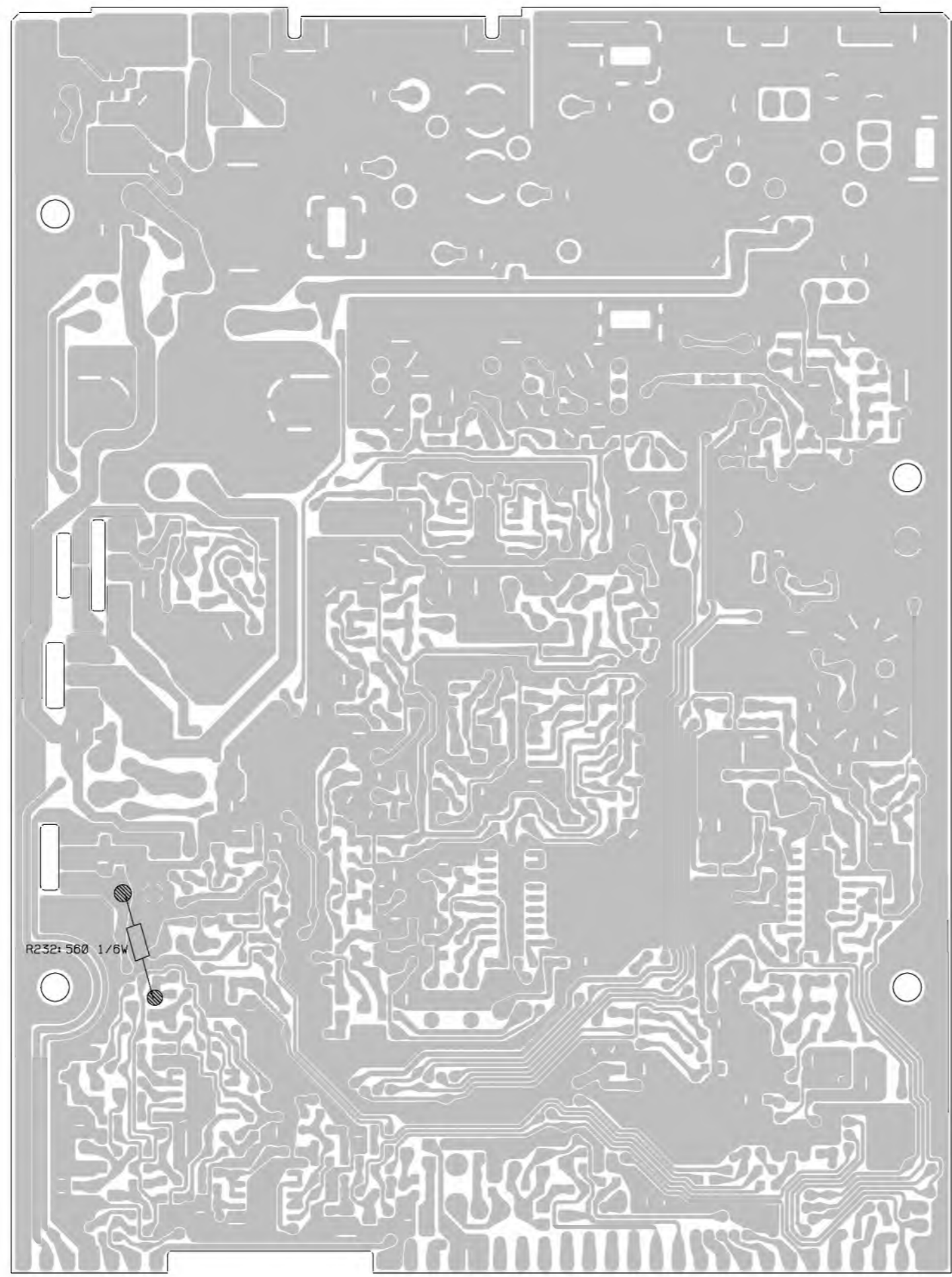

DESIGN. BY	DRAWN. BY	UNIDEN NO. UT370AH	MODEL NO. HARRY II Classic
CHECK. BY	APPRO. BY	TITLE MAIN PCB PARTS ASS'Y BOTTOM VIEW	
		DRAWING NO.	
REV. NO.		UNIDEN CORP.	

HARRY II ASC

COMPONENT LAYOUT

B001: PA-435AA 1/4 (TOP VIEW)

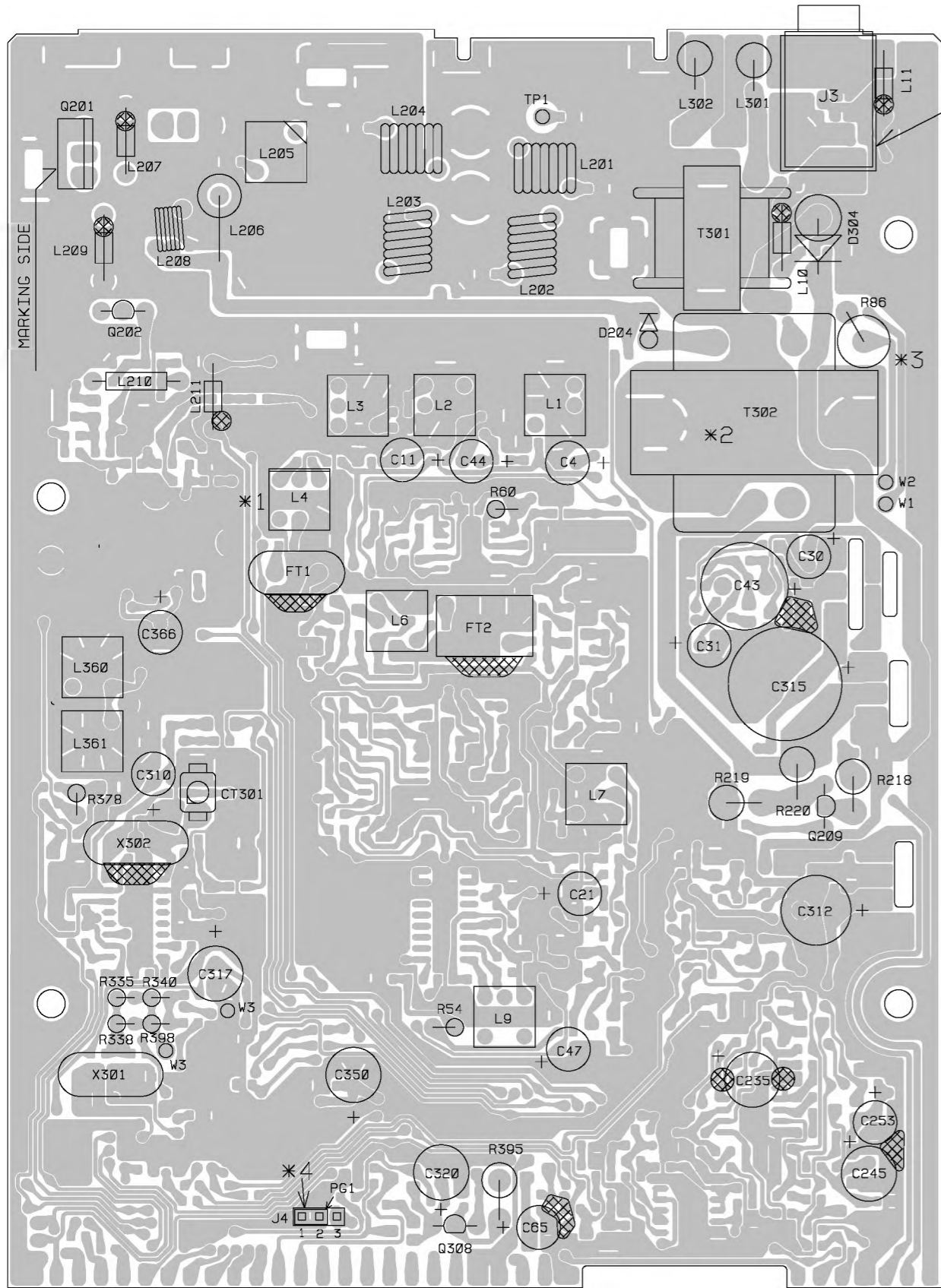

PUT JAPANESE TAPE
UNDER J3

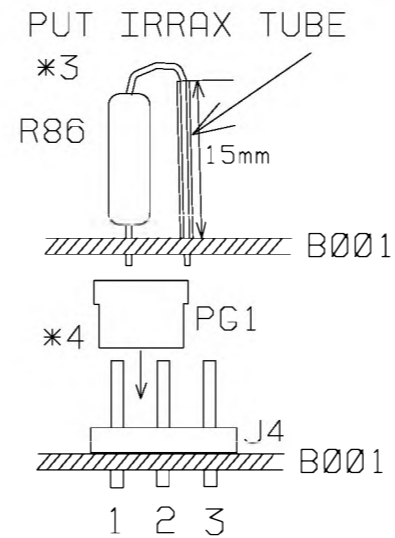
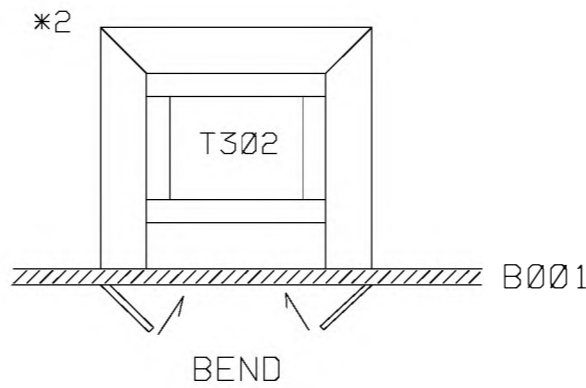
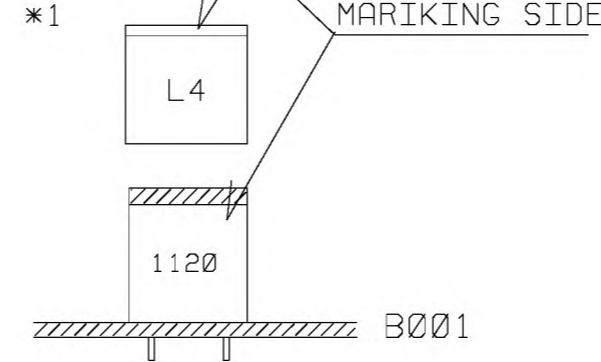

= YELLOW BOND LOCK(SC-121)

C004	4.7UF 50V	C-0156
C011	1UF 50V	C-0156
C021	0.47UF 50V	C-0156
C030	47UF 25V	C-0156
C031	47UF 25V	C-0156
C043	47UF 25V	C-0156
C044	47UF 25V	C-0156
C047	47UF 25V	C-0156
C065	47UF 25V	C-0156
C235	100UF 16V	C-0156
C245	22UF 10V	C-0156
C253	47UF 25V	C-0156
C310	47UF 25V	C-0156
C312	47UF 10V	C-0156
C315	100UF 25V	C-0156
C317	22UF 10V	C-0156
C320	22UF 10V	C-0156
C350	22UF 10V	C-0156
C366	22UF 50V	C-0156

R378	10K 1/4W
R395	56 1WS
R398	10K 1/4W
T301	TF-157
T302	TF-215
TP001	TP-122 1820-01-PP1
W001	UL1007 #24 10-140-3 GRAY
W002	UL1007 #24 10-140-3 WHT
W003	UL1571 #26 5-30-5 WHT
X301	GX-796 4.258996MHZ
X302	GX-074 10.240MHZ

CT301	CT-090 ECR-LA050M52 50PF
D204	GD 1N4003-A2
D304	SB340

FT001	FL-055 10M07RZ
FT002	FL-852 LTS455HTW
J003	JK-899 JH3501-0200
J004	JK-1249 IMSA-9210B-1-0370

L001	LB-1131 KS2484F
L002	LB-1153 KS2485NC
L003	LB-1227
L004	LB-1120 KS2482AC
L006	LB-1129 7PL4A151N
L007	LB-1179 7MK4A033N
L009	LB-1175 7002BE-A0026HM
L010	LD-087 BF04-3*5*1
L011	LD-087 BF04-3*5*1
L201	LE-475 AC1979
L202	LE-486 AC1973
L203	LE-486 AC1973
L204	LE-475 AC1979
L205	LC-255 MD146-08F42
L206	LD-252 3A1737RH
L207	LD-087 BF04-3*5*1
L208	LE-535
L209	LD-087 BF04-3*5*1
L210	LZ-041 0.33UH
L211	LD-087 BF04-3*5*1
L301	LD-252 3A1737RH
L302	LD-252 3A1737RH
L360	LB-1226
L361	LB-1226

PG001	PG-185 IMSA-9215H-T
Q201	DB-792 2SC2314F
Q202	DB-301 2SC941TM-0
Q209	DB-867 2SC3243-T11-E
Q308	DB-867 2SC3243-T11-E

R054	33K 1/4W
R060	100K 1/4W
R086	4.7 3WS
R218	82 1WS
R219	82 1WS
R220	100 1WS
R335	10K 1/6W
R338	10K 1/6W
R340	10K 1/6W

NOTES:
1. RESISTANCE VALUES ARE SHOWN IN OHMS UNLESS OTHERWISE NOTED. (K=KILO OHM, M=MEG OHM)
2. CAPACITANCE VALUES ARE INDICATED IN MICRO FARADS UNLESS OTHERWISE NOTED.

REVISIONS	REV. CODE	DATE	LOT#/RN#	REVISED BY	CHECKED BY

DESIGN BY	DRAWN BY	UNIDEN NO. UT370ZH	MODEL NO. HARRY II ASC
CHECK BY	APPROV BY	TITLE PARTS ASS'Y TOP VIEW	
REV. NO.		DRAWING NO.	
UNIDEN CORP.			

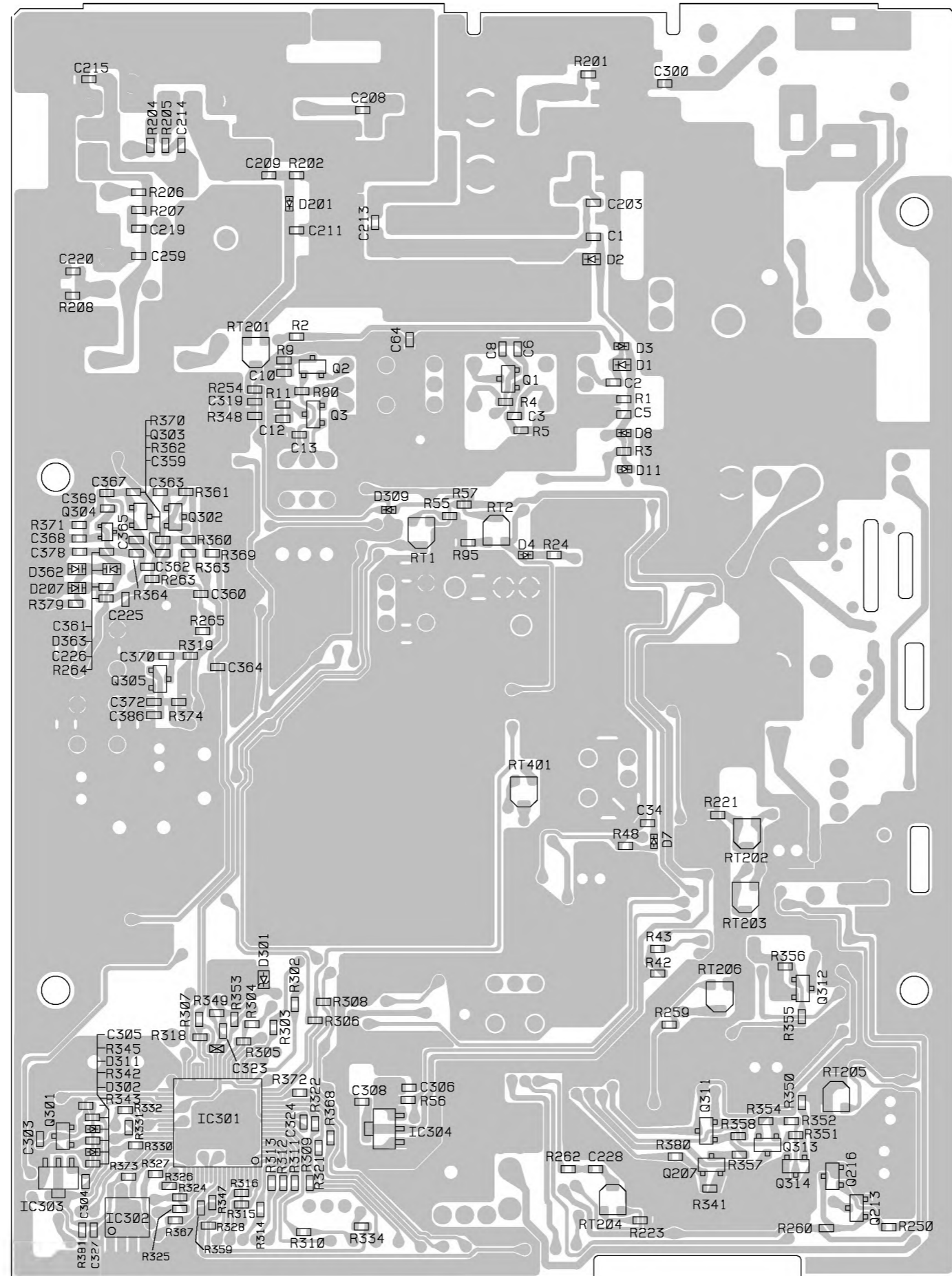

REVISIONS	REV. CODE																			
	DATE																			
	LOT#/RN#																			
	REVISED BY																			
	CHECKED BY																			

DESIGN. BY	DRAWN. BY	UNIDEN NO.	MODEL NO.
		UT370ZH	HARRY II ASC
CHECK. BY	APPRO. BY	TITLE MAIN PCB 1/2 CHIP LAYOUT TOP VIEW	
		DRAWING NO.	
REV. NO.		UNIDEN CORP.	

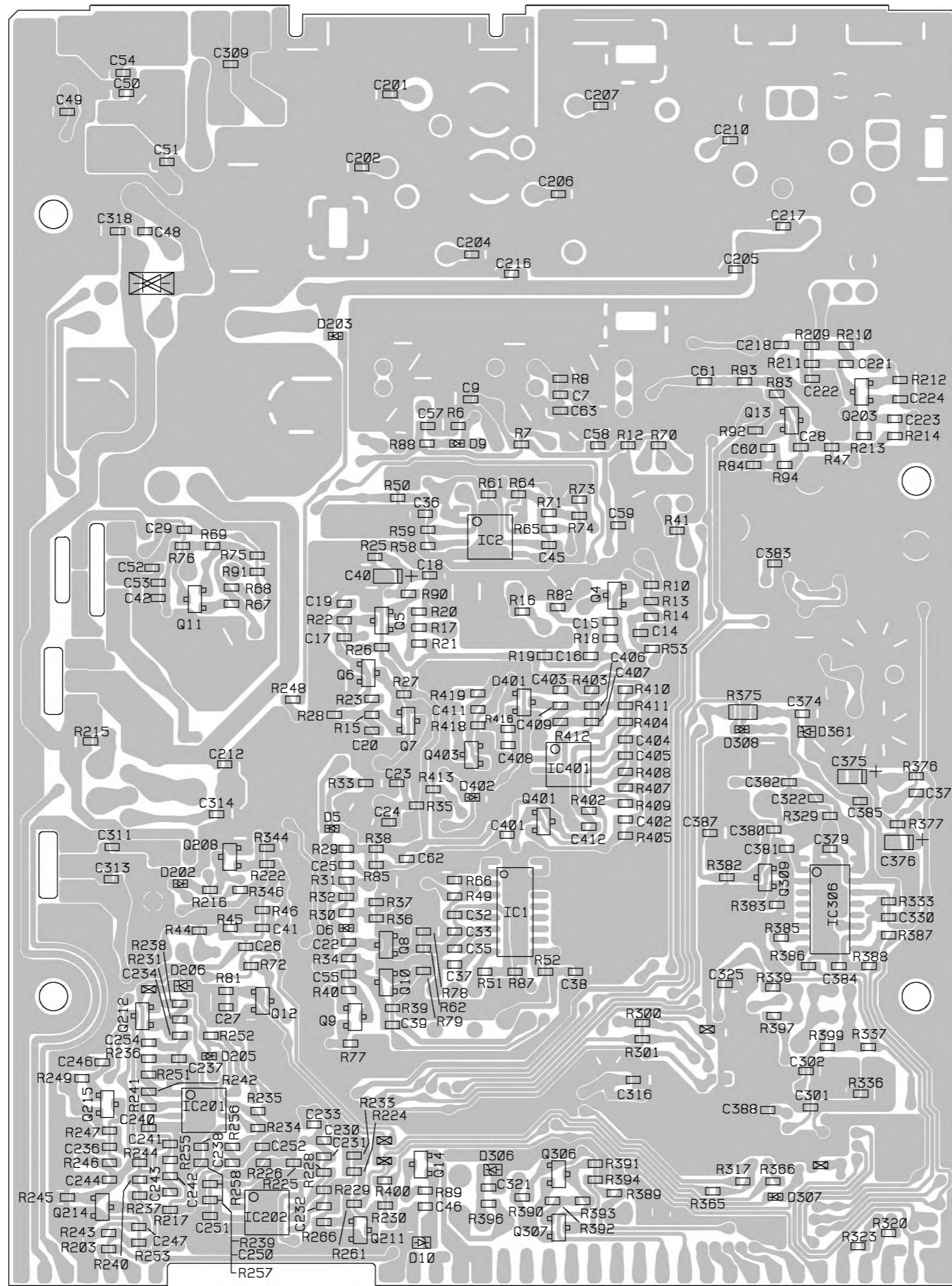

REV. CODE	△	△	△	△	△	△	△	△	△	△	△	△	△	△	△	△	△	△	△
DATE																			
LOT#/RN#																			
REVISED BY																			
CHECKED BY																			

DESIGN. BY	DRAWN. BY	UNIDEN NO.	MODEL NO.
		UT370ZH	HARRY II ASC
CHECK. BY	APPRD. BY	TITLE MAIN PCB 1/2 CHIP LAYOUT BOTTOM VIEW	
		DRAWING NO.	
REV. NO.		UNIDEN CORP.	

REVISIONS	REV. CODE	△	△	△	△	△	△	△	△	△	△	△	△	△	△
	DATE														
	LOT#/RN#														
	REVISED BY														
	CHECKED BY														

 : SOLDERING
 * APPLY THERMAL COMPOUND
 Y501, 502: BOTH SIDE
 IC501, 502, Q503 : REAR SIDE
 HEAT SINK(HHSK4B9767Z) : REAR SIDE(CHASSIS SIDE)

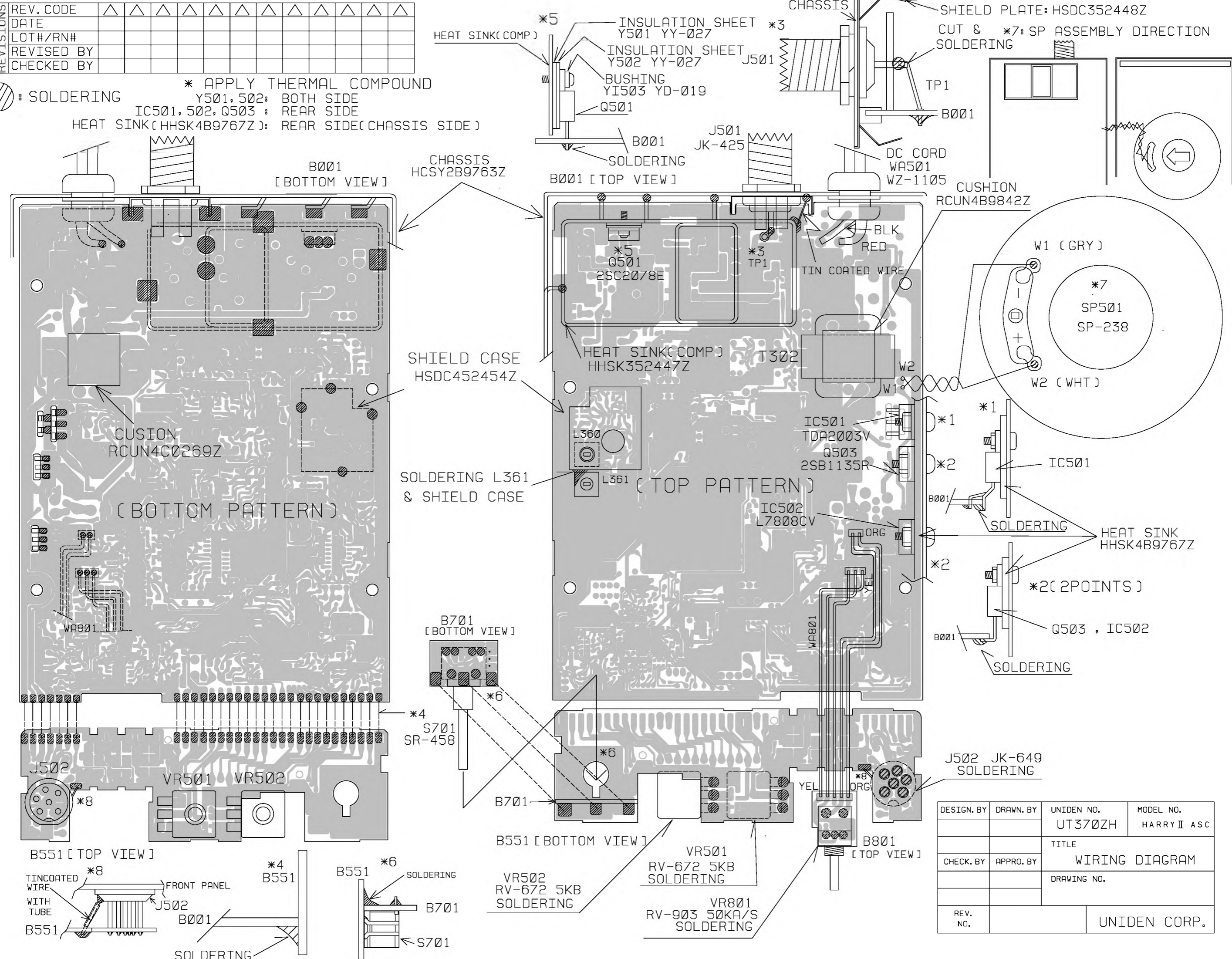

DESIGN. BY	DRAWN. BY	UNIDEN NO.	MODEL NO.
		UT370ZH	HARRY II ASC
TITLE		WIRING DIAGRAM	
CHECK. BY	APPRO. BY	DRAWING NO.	
REV. NO.	UNIDEN CORP.		

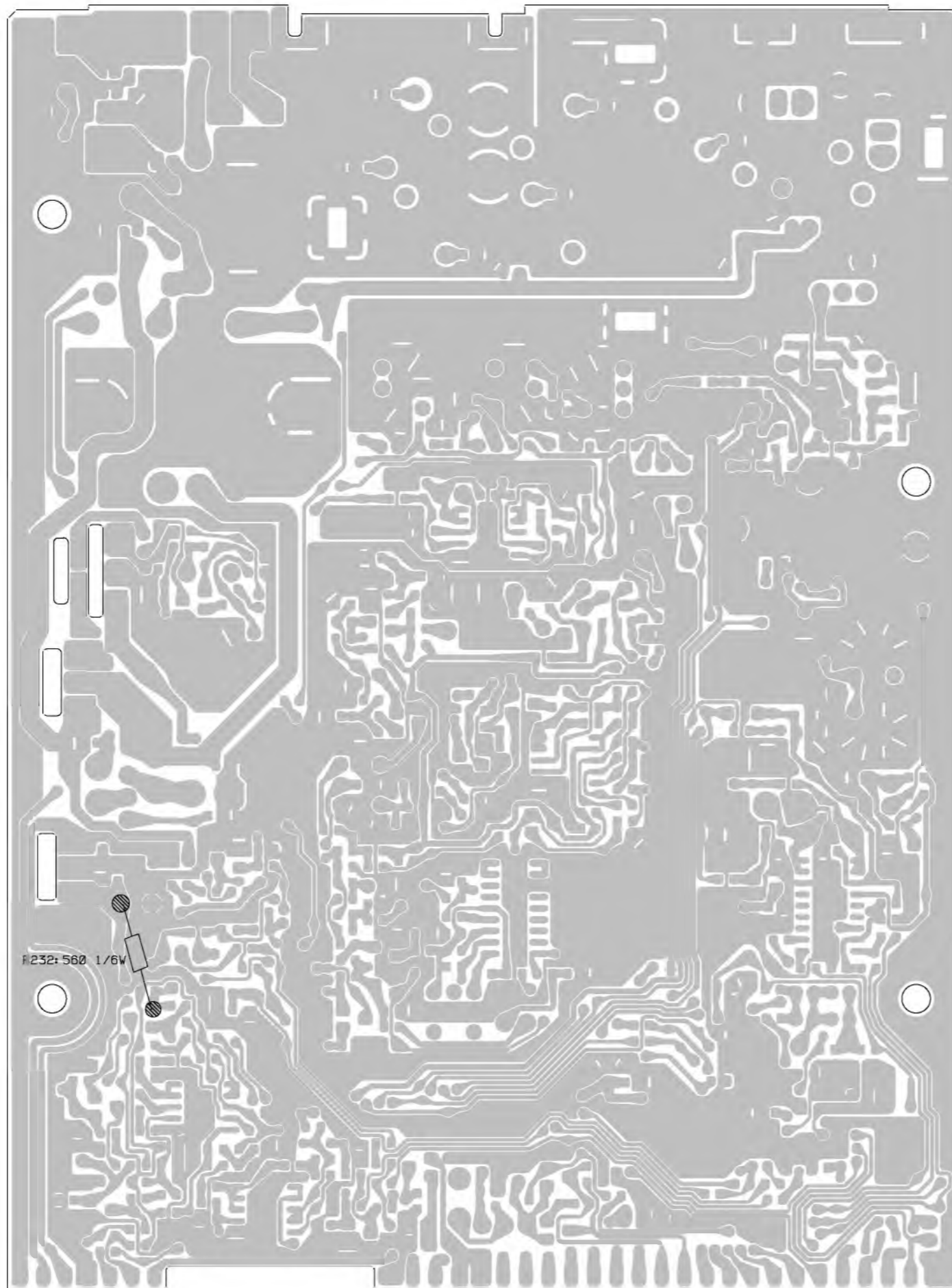

R232: 560 1/6W

DESIGN. BY	DRAWN. BY	UNIDEN NO. UT370ZH	MODEL NO. HARRY II ASC
CHECK. BY	APPRO. BY	TITLE MAIN PCB PARTS ASS'Y BOTTOM VIEW	
		DRAWING NO.	
REV. NO.		UNIDEN CORP.	

COMPONENTS LIST

JOHNNY II ASC

MODEL	JHONNY II ASC	TOTAL	674		
ASSY CODE	PARTS CODE	DESCRIPTION	SPEC	REF NO	QTY
AT371ZHBAE	BCAZ112216Z	C:ELECTROLYTIC	220UF 10V M C-156	C245	1
AT371ZHBAE	BCAZ112216Z	C:ELECTROLYTIC	220UF 10V M C-156	C317	1
AT371ZHBAE	BCAZ112216Z	C:ELECTROLYTIC	220UF 10V M C-156	C320	1
AT371ZHBAE	BCAZ112216Z	C:ELECTROLYTIC	220UF 10V M C-156	C350	1
AT371ZHBAE	BCAZ114716Z	C:ELECTROLYTIC	470UF 10V M C-156	C312	1
AT371ZHBAE	BCAZ311026Z	C:ELECTROLYTIC	1000UF 16V M C-156	C235	1
AT371ZHBAE	BCAZ511026Z	C:ELECTROLYTIC	1000UF 25V M C-156	C315	1
AT371ZHBAE	BCAZ514706Z	C:ELECTROLYTIC	47UF 25V M C-156	C030	1
AT371ZHBAE	BCAZ514706Z	C:ELECTROLYTIC	47UF 25V M C-156	C031	1
AT371ZHBAE	BCAZ514706Z	C:ELECTROLYTIC	47UF 25V M C-156	C044	1
AT371ZHBAE	BCAZ514706Z	C:ELECTROLYTIC	47UF 25V M C-156	C047	1
AT371ZHBAE	BCAZ514706Z	C:ELECTROLYTIC	47UF 25V M C-156	C065	1
AT371ZHBAE	BCAZ514706Z	C:ELECTROLYTIC	47UF 25V M C-156	C253	1
AT371ZHBAE	BCAZ514706Z	C:ELECTROLYTIC	47UF 25V M C-156	C310	1
AT371ZHBAE	BCAZ514716Z	C:ELECTROLYTIC	470UF 25V M C-156	C043	1
AT371ZHBAE	BCAZ811096Z	C:ELECTROLYTIC	1UF 50V M C-156	C011	1
AT371ZHBAE	BCAZ812206Z	C:ELECTROLYTIC	22UF 50V M C-156	C366	1
AT371ZHBAE	BCAZ814786Z	C:ELECTROLYTIC	0.47UF 50V M C-156	C021	1
AT371ZHBAE	BCAZ814796Z	C:ELECTROLYTIC	4.7UF 50V M C-156	C004	1
AT371ZHBAE	BCMF111050Z	C:CERAMIC M/L (1608) TAPE	1UF 10V Z F	C036	1
AT371ZHBAE	BCMF111050Z	C:CERAMIC M/L (1608) TAPE	1UF 10V Z F	C237	1
AT371ZHBAE	BCMF111050Z	C:CERAMIC M/L (1608) TAPE	1UF 10V Z F	C240	1
AT371ZHBAE	BCMF111050Z	C:CERAMIC M/L (1608) TAPE	1UF 10V Z F	C408	1
AT371ZHBAE	BCMF111050Z	C:CERAMIC M/L (1608) TAPE	1UF 10V Z F	C411	1
AT371ZHBAE	BCML311045Z	C:CERAMIC M/L (1608) TAPE	0.1UF 16V K B	C023	1
AT371ZHBAE	BCML311045Z	C:CERAMIC M/L (1608) TAPE	0.1UF 16V K B	C024	1
AT371ZHBAE	BCML311045Z	C:CERAMIC M/L (1608) TAPE	0.1UF 16V K B	C026	1
AT371ZHBAE	BCML311045Z	C:CERAMIC M/L (1608) TAPE	0.1UF 16V K B	C027	1
AT371ZHBAE	BCML311045Z	C:CERAMIC M/L (1608) TAPE	0.1UF 16V K B	C042	1
AT371ZHBAE	BCML311045Z	C:CERAMIC M/L (1608) TAPE	0.1UF 16V K B	C045	1
AT371ZHBAE	BCML311045Z	C:CERAMIC M/L (1608) TAPE	0.1UF 16V K B	C046	1
AT371ZHBAE	BCML311045Z	C:CERAMIC M/L (1608) TAPE	0.1UF 16V K B	C053	1
AT371ZHBAE	BCML311045Z	C:CERAMIC M/L (1608) TAPE	0.1UF 16V K B	C055	1
AT371ZHBAE	BCML311045Z	C:CERAMIC M/L (1608) TAPE	0.1UF 16V K B	C212	1
AT371ZHBAE	BCML311045Z	C:CERAMIC M/L (1608) TAPE	0.1UF 16V K B	C238	1
AT371ZHBAE	BCML311045Z	C:CERAMIC M/L (1608) TAPE	0.1UF 16V K B	C243	1
AT371ZHBAE	BCML311045Z	C:CERAMIC M/L (1608) TAPE	0.1UF 16V K B	C247	1
AT371ZHBAE	BCML311045Z	C:CERAMIC M/L (1608) TAPE	0.1UF 16V K B	C254	1
AT371ZHBAE	BCML311045Z	C:CERAMIC M/L (1608) TAPE	0.1UF 16V K B	C304	1
AT371ZHBAE	BCML311045Z	C:CERAMIC M/L (1608) TAPE	0.1UF 16V K B	C306	1
AT371ZHBAE	BCML311045Z	C:CERAMIC M/L (1608) TAPE	0.1UF 16V K B	C308	1
AT371ZHBAE	BCML311045Z	C:CERAMIC M/L (1608) TAPE	0.1UF 16V K B	C311	1
AT371ZHBAE	BCML311045Z	C:CERAMIC M/L (1608) TAPE	0.1UF 16V K B	C319	1
AT371ZHBAE	BCML311045Z	C:CERAMIC M/L (1608) TAPE	0.1UF 16V K B	C321	1
AT371ZHBAE	BCML311045Z	C:CERAMIC M/L (1608) TAPE	0.1UF 16V K B	C324	1
AT371ZHBAE	BCML311045Z	C:CERAMIC M/L (1608) TAPE	0.1UF 16V K B	C325	1
AT371ZHBAE	BCML311045Z	C:CERAMIC M/L (1608) TAPE	0.1UF 16V K B	C372	1
AT371ZHBAE	BCML311045Z	C:CERAMIC M/L (1608) TAPE	0.1UF 16V K B	C387	1
AT371ZHBAE	BCML311045Z	C:CERAMIC M/L (1608) TAPE	0.1UF 16V K B	C388	1
AT371ZHBAE	BCML311045Z	C:CERAMIC M/L (1608) TAPE	0.1UF 16V K B	C412	1
AT371ZHBAE	BCML311055Z	C:CERAMIC M/L (1608) TAPE	1UF 16V K B	C403	1
AT371ZHBAE	BCML315635Z	C:CERAMIC M/L (1608) TAPE	0.056UF 16V K B	C231	1
AT371ZHBAE	BCML811025Z	C:CERAMIC M/L (1608) TAPE	0.001UF 50V K B	C003	1
AT371ZHBAE	BCML811025Z	C:CERAMIC M/L (1608) TAPE	0.001UF 50V K B	C005	1
AT371ZHBAE	BCML811025Z	C:CERAMIC M/L (1608) TAPE	0.001UF 50V K B	C022	1
AT371ZHBAE	BCML811025Z	C:CERAMIC M/L (1608) TAPE	0.001UF 50V K B	C028	1
AT371ZHBAE	BCML811025Z	C:CERAMIC M/L (1608) TAPE	0.001UF 50V K B	C034	1
AT371ZHBAE	BCML811025Z	C:CERAMIC M/L (1608) TAPE	0.001UF 50V K B	C048	1
AT371ZHBAE	BCML811025Z	C:CERAMIC M/L (1608) TAPE	0.001UF 50V K B	C049	1
AT371ZHBAE	BCML811025Z	C:CERAMIC M/L (1608) TAPE	0.001UF 50V K B	C051	1
AT371ZHBAE	BCML811025Z	C:CERAMIC M/L (1608) TAPE	0.001UF 50V K B	C054	1
AT371ZHBAE	BCML811025Z	C:CERAMIC M/L (1608) TAPE	0.001UF 50V K B	C061	1
AT371ZHBAE	BCML811025Z	C:CERAMIC M/L (1608) TAPE	0.001UF 50V K B	C221	1

MODEL	JHONNY II ASC	TOTAL	674		
ASSY CODE	PARTS CODE	DESCRIPTION	SPEC	REF NO	QTY
AT371ZHBAE	BCML814735Z	C:CERAMIC M/L (1608) TAPE	0.047UF 50V K B	C246	1
AT371ZHBAE	BCML814735Z	C:CERAMIC M/L (1608) TAPE	0.047UF 50V K B	C250	1
AT371ZHBAE	BCML814735Z	C:CERAMIC M/L (1608) TAPE	0.047UF 50V K B	C313	1
AT371ZHBAE	BCML814735Z	C:CERAMIC M/L (1608) TAPE	0.047UF 50V K B	C316	1
AT371ZHBAE	BCML814735Z	C:CERAMIC M/L (1608) TAPE	0.047UF 50V K B	C330	1
AT371ZHBAE	BCML814735Z	C:CERAMIC M/L (1608) TAPE	0.047UF 50V K B	C409	1
AT371ZHBAE	BCMM811002Z	C:CERAMIC M/L (1608) TAPE	10PF 50V D CH	C367	1
AT371ZHBAE	BCMM811002Z	C:CERAMIC M/L (1608) TAPE	10PF 50V D CH	C378	1
AT371ZHBAE	BCMM811014Z	C:CERAMIC M/L (1608) TAPE	100PF 50V J CH	C006	1
AT371ZHBAE	BCMM811014Z	C:CERAMIC M/L (1608) TAPE	100PF 50V J CH	C062	1
AT371ZHBAE	BCMM811214Z	C:CERAMIC M/L (1608) TAPE	120PF 50V J CH	C201	1
AT371ZHBAE	BCMM811214Z	C:CERAMIC M/L (1608) TAPE	120PF 50V J CH	C219	1
AT371ZHBAE	BCMM811504Z	C:CERAMIC M/L (1608) TAPE	15PF 50V J CH	C213	1
AT371ZHBAE	BCMM811514Z	C:CERAMIC M/L (1608) TAPE	150PF 50V J CH	C368	1
AT371ZHBAE	BCMM811514Z	C:CERAMIC M/L (1608) TAPE	150PF 50V J CH	C369	1
AT371ZHBAE	BCMM811804Z	C:CERAMIC M/L (1608) TAPE	18PF 50V J CH	C203	1
AT371ZHBAE	BCMM811804Z	C:CERAMIC M/L (1608) TAPE	18PF 50V J CH	C225	1
AT371ZHBAE	BCMM811804Z	C:CERAMIC M/L (1608) TAPE	18PF 50V J CH	C381	1
AT371ZHBAE	BCMM811804Z	C:CERAMIC M/L (1608) TAPE	18PF 50V J CH	C382	1
AT371ZHBAE	BCMM811814Z	C:CERAMIC M/L (1608) TAPE	180PF 50V J CH	C204	1
AT371ZHBAE	BCMM811814Z	C:CERAMIC M/L (1608) TAPE	180PF 50V J CH	C206	1
AT371ZHBAE	BCMM812098Z	C:CERAMIC M/L (1608) TAPE	2PF 50V B CH	C363	1
AT371ZHBAE	BCMM812204Z	C:CERAMIC M/L (1608) TAPE	22PF 50V J CH	C001	1
AT371ZHBAE	BCMM812204Z	C:CERAMIC M/L (1608) TAPE	22PF 50V J CH	C301	1
AT371ZHBAE	BCMM812204Z	C:CERAMIC M/L (1608) TAPE	22PF 50V J CH	C302	1
AT371ZHBAE	BCMM812204Z	C:CERAMIC M/L (1608) TAPE	22PF 50V J CH	C380	1
AT371ZHBAE	BCMM812214Z	C:CERAMIC M/L (1608) TAPE	220PF 50V J CH	C202	1
AT371ZHBAE	BCMM812214Z	C:CERAMIC M/L (1608) TAPE	220PF 50V J CH	C208	1
AT371ZHBAE	BCMM812214Z	C:CERAMIC M/L (1608) TAPE	220PF 50V J CH	C223	1
AT371ZHBAE	BCMM812704Z	C:CERAMIC M/L (1608) TAPE	27PF 50V J CH	C063	1
AT371ZHBAE	BCMM812704Z	C:CERAMIC M/L (1608) TAPE	27PF 50V J CH	C224	1
AT371ZHBAE	BCMM813098Z	C:CERAMIC M/L (1608) TAPE	3PF 50V B CH	C007	1
AT371ZHBAE	BCMM813314Z	C:CERAMIC M/L (1608) TAPE	330PF 50V J CH	C207	1
AT371ZHBAE	BCMM813314Z	C:CERAMIC M/L (1608) TAPE	330PF 50V J CH	C214	1
AT371ZHBAE	BCMM813904Z	C:CERAMIC M/L (1608) TAPE	39PF 50V J CH	C215	1
AT371ZHBAE	BCMM813904Z	C:CERAMIC M/L (1608) TAPE	39PF 50V J CH	C322	1
AT371ZHBAE	BCMM814704Z	C:CERAMIC M/L (1608) TAPE	47PF 50V J CH	C041	1
AT371ZHBAE	BCMM815091Z	C:CERAMIC M/L (1608) TAPE	5PF 50V C CH	C226	1
AT371ZHBAE	BCMM815604Z	C:CERAMIC M/L (1608) TAPE	56PF 50V J CH	C361	1
AT371ZHBAE	BCMM815614Z	C:CERAMIC M/L (1608) TAPE	560PF 50V J CH	C015	1
AT371ZHBAE	BCMM816804Z	C:CERAMIC M/L (1608) TAPE	68PF 50V J CH	C259	1
AT371ZHBAE	BCMM816814Z	C:CERAMIC M/L (1608) TAPE	680PF 50V J CH	C232	1
AT371ZHBAE	BCMM818204Z	C:CERAMIC M/L (1608) TAPE	82PF 50V J CH	C210	1
AT371ZHBAE	BCMS812091Z	C:CERAMIC M/L (1608) TAPE	2PF 50V C CK	C209	1
AT371ZHBAE	BESH464796Z	C:TANTALUM CHIP TAPE	4.7UF 20V M A C-122	C040	1
AT371ZHBAE	BESH514786Z	C:TANTALUM CHIP TAPE	0.47UF 25V M C-122 TAPE	C376	1
AT371ZHBAE	BESH661086Z	CAPACITOR:TANTALUM CHIP	0.1UF 35V M C-122 TAPE	C375	1
AT371ZHBAE	BCTY0090500	C:TRIMMER	CT-090 ECR-LA050M52 50PF	CT301	1
AT371ZHBAE	BDAY0274001	DIODE	1SS226 TE85L	D401	1
AT371ZHBAE	BDAY0808001	DIODE:SWITCHING	1SS356 TW11	D001	1
AT371ZHBAE	BDAY0808001	DIODE:SWITCHING	1SS356 TW11	D002	1
AT371ZHBAE	BDAY0811001	DIODE	SB340	D304	1
AT371ZHBAE	BDAY0940001	DIODE:VARICAP	HVU307 TRU	D362	1
AT371ZHBAE	BDAY0940001	DIODE:VARICAP	HVU307 TRU	D363	1
AT371ZHBAE	BDAY0993001	DIODE	KDS160E-RTK	D003	1
AT371ZHBAE	BDAY0993001	DIODE	KDS160E-RTK	D004	1
AT371ZHBAE	BDAY0993001	DIODE	KDS160E-RTK	D005	1
AT371ZHBAE	BDAY0993001	DIODE	KDS160E-RTK	D006	1
AT371ZHBAE	BDAY0993001	DIODE	KDS160E-RTK	D007	1
AT371ZHBAE	BDAY0993001	DIODE	KDS160E-RTK	D008	1
AT371ZHBAE	BDAY0993001	DIODE	KDS160E-RTK	D009	1
AT371ZHBAE	BDAY0993001	DIODE	KDS160E-RTK	D011	1
AT371ZHBAE	BDAY0993001	DIODE	KDS160E-RTK	D201	1
AT371ZHBAE	BDAY0993001	DIODE	KDS160E-RTK	D202	1

MODEL	JHONNY II ASC	TOTAL	674		
ASSY CODE	PARTS CODE	DESCRIPTION	SPEC	REF NO	QTY
AT371ZHBAE	BDAY0993001	DIODE	KDS160E-RTK	D203	1
AT371ZHBAE	BDAY0993001	DIODE	KDS160E-RTK	D205	1
AT371ZHBAE	BDAY0993001	DIODE	KDS160E-RTK	D302	1
AT371ZHBAE	BDAY0993001	DIODE	KDS160E-RTK	D307	1
AT371ZHBAE	BDAY0993001	DIODE	KDS160E-RTK	D308	1
AT371ZHBAE	BDAY0993001	DIODE	KDS160E-RTK	D309	1
AT371ZHBAE	BDAY0993001	DIODE	KDS160E-RTK	D311	1
AT371ZHBAE	BDAY0993001	DIODE	KDS160E-RTK	D402	1
AT371ZHBAE	BDAY1082004	DIODE:ZENER	UDZS5.1B TE-17	D306	1
AT371ZHBAE	BDAY1082004	DIODE:ZENER	UDZS5.1B TE-17	D361	1
AT371ZHBAE	BDAY1082013	DIODE:ZENER	UDZS5.6B TE-17	D010	1
AT371ZHBAE	BDAY1082015	DIODE:ZENER	UDZS7.5B TE-17	D301	1
AT371ZHBAE	BDAY1082016	DIODE:ZENER	UDZS3.0B TE-17	D206	1
AT371ZHBAE	BDAY1185001	DIODE	GD 1N4003-A2	D204	1
AT371ZHBAE	BDBA1235106	TRANSISTOR	DB-092 2SA1235A-T12-1F	Q212	1
AT371ZHBAE	BDBA1235106	TRANSISTOR	DB-092 2SA1235A-T12-1F	Q215	1
AT371ZHBAE	BDBA1235106	TRANSISTOR	DB-092 2SA1235A-T12-1F	Q306	1
AT371ZHBAE	BDBA1235106	TRANSISTOR	DB-092 2SA1235A-T12-1F	Q307	1
AT371ZHBAE	BDBA1235106	TRANSISTOR	DB-092 2SA1235A-T12-1F	Q311	1
AT371ZHBAE	BDBC0941523	TRANSISTOR	DB-301 2SC941TM-O	Q202	1
AT371ZHBAE	BDBC2314106	TRANSISTOR	DB-792 2SC2314F	Q201	1
AT371ZHBAE	BDBC2714124	TRANSISTOR	DB-718 2SC2714-Y TE85L	Q001	1
AT371ZHBAE	BDBC2714124	TRANSISTOR	DB-718 2SC2714-Y TE85L	Q004	1
AT371ZHBAE	BDBC2714124	TRANSISTOR	DB-718 2SC2714-Y TE85L	Q005	1
AT371ZHBAE	BDBC2714124	TRANSISTOR	DB-718 2SC2714-Y TE85L	Q013	1
AT371ZHBAE	BDBC2714124	TRANSISTOR	DB-718 2SC2714-Y TE85L	Q203	1
AT371ZHBAE	BDBC2714124	TRANSISTOR	DB-718 2SC2714-Y TE85L	Q302	1
AT371ZHBAE	BDBC2714124	TRANSISTOR	DB-718 2SC2714-Y TE85L	Q303	1
AT371ZHBAE	BDBC3052106	TRANSISTOR	DB-862 2SC3052-T12-1F	Q006	1
AT371ZHBAE	BDBC3052106	TRANSISTOR	DB-862 2SC3052-T12-1F	Q007	1
AT371ZHBAE	BDBC3052106	TRANSISTOR	DB-862 2SC3052-T12-1F	Q009	1
AT371ZHBAE	BDBC3052106	TRANSISTOR	DB-862 2SC3052-T12-1F	Q011	1
AT371ZHBAE	BDBC3052106	TRANSISTOR	DB-862 2SC3052-T12-1F	Q012	1
AT371ZHBAE	BDBC3052106	TRANSISTOR	DB-862 2SC3052-T12-1F	Q014	1
AT371ZHBAE	BDBC3052106	TRANSISTOR	DB-862 2SC3052-T12-1F	Q207	1
AT371ZHBAE	BDBC3052106	TRANSISTOR	DB-862 2SC3052-T12-1F	Q208	1
AT371ZHBAE	BDBC3052106	TRANSISTOR	DB-862 2SC3052-T12-1F	Q213	1
AT371ZHBAE	BDBC3052106	TRANSISTOR	DB-862 2SC3052-T12-1F	Q216	1
AT371ZHBAE	BDBC3052106	TRANSISTOR	DB-862 2SC3052-T12-1F	Q301	1
AT371ZHBAE	BDBC3052106	TRANSISTOR	DB-862 2SC3052-T12-1F	Q309	1
AT371ZHBAE	BDBC3052106	TRANSISTOR	DB-862 2SC3052-T12-1F	Q312	1
AT371ZHBAE	BDBC3052106	TRANSISTOR	DB-862 2SC3052-T12-1F	Q401	1
AT371ZHBAE	BDBC3052106	TRANSISTOR	DB-862 2SC3052-T12-1F	Q403	1
AT371ZHBAE	BDBC3243105	TRANSISTOR	DB-867 2SC3243-T11-E	Q209	1
AT371ZHBAE	BDBC3243105	TRANSISTOR	DB-867 2SC3243-T11-E	Q308	1
AT371ZHBAE	BDBC5065124	TRANSISTOR	DB-848 2SC5065-Y(TE85R)	Q304	1
AT371ZHBAE	BDBD1048661	TRANSISTOR	DB-435 2SD1048-X6 TB	Q010	1
AT371ZHBAE	BDBD1048661	TRANSISTOR	DB-435 2SD1048-X6 TB	Q214	1
AT371ZHBAE	BDBD1048661	TRANSISTOR	DB-435 2SD1048-X6 TB	Q305	1
AT371ZHBAE	BDCB0210301	FIELD EFFECT TRANSISTOR	DC-022 2SK210-BL TE85L	Q002	1
AT371ZHBAE	BDCB0210301	FIELD EFFECT TRANSISTOR	DC-022 2SK210-BL TE85L	Q003	1
AT371ZHBAE	BDDG1515001	INTEGRATED CIRCUIT:UC2971	UPD780021AGB-G26-8EU-A	IC301	1
AT371ZHBAE	BDEG4251003	INTEGRATED CIRCUIT	RH5RL50AA-T1-FA	IC304	1
AT371ZHBAE	BDEY2769003	INTEGRATED CIRCUIT	BU2630F-E2	IC306	1
AT371ZHBAE	BDEY3654003	INTEGRATED CIRCUIT	NJM12904M-TE3--#ZZZB	IC002	1
AT371ZHBAE	BDEY3654003	INTEGRATED CIRCUIT	NJM12904M-TE3--#ZZZB	IC201	1
AT371ZHBAE	BDEY3654003	INTEGRATED CIRCUIT	NJM12904M-TE3--#ZZZB	IC202	1
AT371ZHBAE	BDEY3654003	INTEGRATED CIRCUIT	NJM12904M-TE3--#ZZZB	IC401	1
AT371ZHBAE	BDEY3664003	INTEGRATED CIRCUIT	S-24CC02A-J8T1	IC302	1
AT371ZHBAE	BDEY4017003	INTEGRATED CIRCUIT	XC61CC4302PR/XC61AC4302PR	IC303	1
AT371ZHBAE	BFLY0055001	FILTER:CRYSTAL	FL-055 10M07AZ	FT001	1
AT371ZHBAE	BFLY0852001	FILTER:CERAMIC	FL-852 LTS455HTW	FT002	1
AT371ZHBAE	BJKG1249003	JACK	JK-1249 IMSA-9210B-1-03Z058-PT1	J004	1
AT371ZHBAE	BJKY0899001	JACK:EARPHONE	JK-899 JH3501-020D	J003	1

MODEL	JHONNY II ASC	TOTAL	674		
ASSY CODE	PARTS CODE	DESCRIPTION	SPEC	REF NO	QTY
AT371ZHBAE	BLBG1226001	COIL	LB-1226 KY1107R	L360	1
AT371ZHBAE	BLBG1226001	COIL	LB-1226 KY1107R	L361	1
AT371ZHBAE	BLBG1227001	COIL	LB-1227 KS2553N	L003	1
AT371ZHBAE	BLBY1120001	COIL	LB-1120 KS2482AC	L004	1
AT371ZHBAE	BLBY1129001	COIL	LB-1129 7PL4A151N	L006	1
AT371ZHBAE	BLBY1131001	COIL	LB-1131 KS2484F	L001	1
AT371ZHBAE	BLBY1153001	COIL	LB-1153 KS2485NC	L002	1
AT371ZHBAE	BLBY1179001	COIL	LB-1179 7MK4A033N	L007	1
AT371ZHBAE	BLCY0255001	COIL	LC-255 MD146-08F42	L205	1
AT371ZHBAE	BLDY0087001	COIL	LD-087 BF04-3*5*1	L010	1
AT371ZHBAE	BLDY0087001	COIL	LD-087 BF04-3*5*1	L011	1
AT371ZHBAE	BLDY0087001	COIL	LD-087 BF04-3*5*1	L207	1
AT371ZHBAE	BLDY0087001	COIL	LD-087 BF04-3*5*1	L209	1
AT371ZHBAE	BLDY0087001	COIL	LD-087 BF04-3*5*1	L211	1
AT371ZHBAE	BLDY0252001	COIL	LD-252 3A1737RH	L206	1
AT371ZHBAE	BLDY0252001	COIL	LD-252 3A1737RH	L301	1
AT371ZHBAE	BLDY0252001	COIL	LD-252 3A1737RH	L302	1
AT371ZHBAE	BLEY0475001	COIL	LE-475 AC1979	L201	1
AT371ZHBAE	BLEY0475001	COIL	LE-475 AC1979	L204	1
AT371ZHBAE	BLEY0486001	COIL	LE-486 AC1973	L202	1
AT371ZHBAE	BLEY0486001	COIL	LE-486 AC1973	L203	1
AT371ZHBAE	BLEY0535001	COIL	LE-535	L208	1
AT371ZHBAE	BLZY0041338	INDUCTOR:MOLDED	LZ-041 0.33UH K	L210	1
AT371ZHBAE	BPAG0435AA1	PCB:MAIN	PA-435AA 1/4	B001	1
AT371ZHBAE	BPGG0185001	PLUG	PG-185 IMSA-9215H-T	PG001	1
AT371ZHBAE	BQXY0074001	CRYSTAL	QX-074 10.240MHZ	X302	1
AT371ZHBAE	BQXY0796001	CRYSTAL	QX-796 4.258996MHZ	X301	1
AT371ZHBAE	BRFC160004Z	R:CARBON FIXED CHIP	0 1/16W J TAPE	R017	1
AT371ZHBAE	BRFC160004Z	R:CARBON FIXED CHIP	0 1/16W J TAPE	R063	1
AT371ZHBAE	BRFC160004Z	R:CARBON FIXED CHIP	0 1/16W J TAPE	R264	1
AT371ZHBAE	BRFC161004Z	R:CARBON FIXED CHIP	10 1/16W J TAPE	R015	1
AT371ZHBAE	BRFC161014Z	R:CARBON FIXED CHIP	100 1/16W J TAPE	R007	1
AT371ZHBAE	BRFC161014Z	R:CARBON FIXED CHIP	100 1/16W J TAPE	R012	1
AT371ZHBAE	BRFC161014Z	R:CARBON FIXED CHIP	100 1/16W J TAPE	R019	1
AT371ZHBAE	BRFC161014Z	R:CARBON FIXED CHIP	100 1/16W J TAPE	R026	1
AT371ZHBAE	BRFC161014Z	R:CARBON FIXED CHIP	100 1/16W J TAPE	R067	1
AT371ZHBAE	BRFC161014Z	R:CARBON FIXED CHIP	100 1/16W J TAPE	R203	1
AT371ZHBAE	BRFC161024Z	R:CARBON FIXED CHIP	1K 1/16W J TAPE	R002	1
AT371ZHBAE	BRFC161024Z	R:CARBON FIXED CHIP	1K 1/16W J TAPE	R016	1
AT371ZHBAE	BRFC161024Z	R:CARBON FIXED CHIP	1K 1/16W J TAPE	R236	1
AT371ZHBAE	BRFC161024Z	R:CARBON FIXED CHIP	1K 1/16W J TAPE	R244	1
AT371ZHBAE	BRFC161024Z	R:CARBON FIXED CHIP	1K 1/16W J TAPE	R246	1
AT371ZHBAE	BRFC161024Z	R:CARBON FIXED CHIP	1K 1/16W J TAPE	R301	1
AT371ZHBAE	BRFC161024Z	R:CARBON FIXED CHIP	1K 1/16W J TAPE	R303	1
AT371ZHBAE	BRFC161024Z	R:CARBON FIXED CHIP	1K 1/16W J TAPE	R304	1
AT371ZHBAE	BRFC161024Z	R:CARBON FIXED CHIP	1K 1/16W J TAPE	R305	1
AT371ZHBAE	BRFC161024Z	R:CARBON FIXED CHIP	1K 1/16W J TAPE	R307	1
AT371ZHBAE	BRFC161024Z	R:CARBON FIXED CHIP	1K 1/16W J TAPE	R318	1
AT371ZHBAE	BRFC161024Z	R:CARBON FIXED CHIP	1K 1/16W J TAPE	R324	1
AT371ZHBAE	BRFC161024Z	R:CARBON FIXED CHIP	1K 1/16W J TAPE	R325	1
AT371ZHBAE	BRFC161024Z	R:CARBON FIXED CHIP	1K 1/16W J TAPE	R327	1
AT371ZHBAE	BRFC161024Z	R:CARBON FIXED CHIP	1K 1/16W J TAPE	R346	1
AT371ZHBAE	BRFC161024Z	R:CARBON FIXED CHIP	1K 1/16W J TAPE	R365	1
AT371ZHBAE	BRFC161024Z	R:CARBON FIXED CHIP	1K 1/16W J TAPE	R367	1
AT371ZHBAE	BRFC161024Z	R:CARBON FIXED CHIP	1K 1/16W J TAPE	R369	1
AT371ZHBAE	BRFC161024Z	R:CARBON FIXED CHIP	1K 1/16W J TAPE	R379	1
AT371ZHBAE	BRFC161024Z	R:CARBON FIXED CHIP	1K 1/16W J TAPE	R385	1
AT371ZHBAE	BRFC161024Z	R:CARBON FIXED CHIP	1K 1/16W J TAPE	R386	1
AT371ZHBAE	BRFC161024Z	R:CARBON FIXED CHIP	1K 1/16W J TAPE	R387	1
AT371ZHBAE	BRFC161024Z	R:CARBON FIXED CHIP	1K 1/16W J TAPE	R391	1
AT371ZHBAE	BRFC161024Z	R:CARBON FIXED CHIP	1K 1/16W J TAPE	R394	1
AT371ZHBAE	BRFC161034Z	R:CARBON FIXED CHIP	10K 1/16W J TAPE	R001	1
AT371ZHBAE	BRFC161034Z	R:CARBON FIXED CHIP	10K 1/16W J TAPE	R029	1
AT371ZHBAE	BRFC161034Z	R:CARBON FIXED CHIP	10K 1/16W J TAPE	R033	1

MODEL	JHONNY II ASC	TOTAL	674		
ASSY CODE	PARTS CODE	DESCRIPTION	SPEC	REF NO	QTY
AT371ZHBAE	BRFC161824Z	R:CARBON FIXED CHIP	1.8K 1/16W J TAPE	R013	1
AT371ZHBAE	BRFC161824Z	R:CARBON FIXED CHIP	1.8K 1/16W J TAPE	R210	1
AT371ZHBAE	BRFC162204Z	R:CARBON FIXED CHIP	22 1/16W J TAPE	R093	1
AT371ZHBAE	BRFC162204Z	R:CARBON FIXED CHIP	22 1/16W J TAPE	R207	1
AT371ZHBAE	BRFC162214Z	R:CARBON FIXED CHIP	220 1/16W J TAPE	R018	1
AT371ZHBAE	BRFC162214Z	R:CARBON FIXED CHIP	220 1/16W J TAPE	R084	1
AT371ZHBAE	BRFC162214Z	R:CARBON FIXED CHIP	220 1/16W J TAPE	R088	1
AT371ZHBAE	BRFC162214Z	R:CARBON FIXED CHIP	220 1/16W J TAPE	R094	1
AT371ZHBAE	BRFC162214Z	R:CARBON FIXED CHIP	220 1/16W J TAPE	R211	1
AT371ZHBAE	BRFC162214Z	R:CARBON FIXED CHIP	220 1/16W J TAPE	R214	1
AT371ZHBAE	BRFC162214Z	R:CARBON FIXED CHIP	220 1/16W J TAPE	R363	1
AT371ZHBAE	BRFC162224Z	R:CARBON FIXED CHIP	2.2K 1/16W J TAPE	R003	1
AT371ZHBAE	BRFC162224Z	R:CARBON FIXED CHIP	2.2K 1/16W J TAPE	R005	1
AT371ZHBAE	BRFC162224Z	R:CARBON FIXED CHIP	2.2K 1/16W J TAPE	R020	1
AT371ZHBAE	BRFC162224Z	R:CARBON FIXED CHIP	2.2K 1/16W J TAPE	R027	1
AT371ZHBAE	BRFC162224Z	R:CARBON FIXED CHIP	2.2K 1/16W J TAPE	R226	1
AT371ZHBAE	BRFC162224Z	R:CARBON FIXED CHIP	2.2K 1/16W J TAPE	R229	1
AT371ZHBAE	BRFC162224Z	R:CARBON FIXED CHIP	2.2K 1/16W J TAPE	R231	1
AT371ZHBAE	BRFC162224Z	R:CARBON FIXED CHIP	2.2K 1/16W J TAPE	R235	1
AT371ZHBAE	BRFC162224Z	R:CARBON FIXED CHIP	2.2K 1/16W J TAPE	R251	1
AT371ZHBAE	BRFC162224Z	R:CARBON FIXED CHIP	2.2K 1/16W J TAPE	R253	1
AT371ZHBAE	BRFC162224Z	R:CARBON FIXED CHIP	2.2K 1/16W J TAPE	R260	1
AT371ZHBAE	BRFC162224Z	R:CARBON FIXED CHIP	2.2K 1/16W J TAPE	R300	1
AT371ZHBAE	BRFC162224Z	R:CARBON FIXED CHIP	2.2K 1/16W J TAPE	R302	1
AT371ZHBAE	BRFC162224Z	R:CARBON FIXED CHIP	2.2K 1/16W J TAPE	R320	1
AT371ZHBAE	BRFC162224Z	R:CARBON FIXED CHIP	2.2K 1/16W J TAPE	R323	1
AT371ZHBAE	BRFC162224Z	R:CARBON FIXED CHIP	2.2K 1/16W J TAPE	R331	1
AT371ZHBAE	BRFC162224Z	R:CARBON FIXED CHIP	2.2K 1/16W J TAPE	R332	1
AT371ZHBAE	BRFC162224Z	R:CARBON FIXED CHIP	2.2K 1/16W J TAPE	R401	1
AT371ZHBAE	BRFC162224Z	R:CARBON FIXED CHIP	2.2K 1/16W J TAPE	R410	1
AT371ZHBAE	BRFC162224Z	R:CARBON FIXED CHIP	2.2K 1/16W J TAPE	R452	1
AT371ZHBAE	BRFC162234Z	R:CARBON FIXED CHIP	22K 1/16W J TAPE	R213	1
AT371ZHBAE	BRFC162234Z	R:CARBON FIXED CHIP	22K 1/16W J TAPE	R345	1
AT371ZHBAE	BRFC162234Z	R:CARBON FIXED CHIP	22K 1/16W J TAPE	R364	1
AT371ZHBAE	BRFC162244Z	R:CARBON FIXED CHIP	220K 1/16W J TAPE	R234	1
AT371ZHBAE	BRFC162244Z	R:CARBON FIXED CHIP	220K 1/16W J TAPE	R402	1
AT371ZHBAE	BRFC162254Z	R:CARBON FIXED CHIP	2.2M 1/16W J TAPE	R056	1
AT371ZHBAE	BRFC162294Z	R:CARBON FIXED CHIP	2.2 1/16W J TAPE	R076	1
AT371ZHBAE	BRFC162714Z	R:CARBON FIXED CHIP	270 1/16W J TAPE	R009	1
AT371ZHBAE	BRFC162714Z	R:CARBON FIXED CHIP	270 1/16W J TAPE	R011	1
AT371ZHBAE	BRFC162714Z	R:CARBON FIXED CHIP	270 1/16W J TAPE	R309	1
AT371ZHBAE	BRFC162714Z	R:CARBON FIXED CHIP	270 1/16W J TAPE	R310	1
AT371ZHBAE	BRFC162714Z	R:CARBON FIXED CHIP	270 1/16W J TAPE	R311	1
AT371ZHBAE	BRFC162714Z	R:CARBON FIXED CHIP	270 1/16W J TAPE	R312	1
AT371ZHBAE	BRFC162714Z	R:CARBON FIXED CHIP	270 1/16W J TAPE	R313	1
AT371ZHBAE	BRFC162714Z	R:CARBON FIXED CHIP	270 1/16W J TAPE	R314	1
AT371ZHBAE	BRFC162714Z	R:CARBON FIXED CHIP	270 1/16W J TAPE	R315	1
AT371ZHBAE	BRFC162714Z	R:CARBON FIXED CHIP	270 1/16W J TAPE	R316	1
AT371ZHBAE	BRFC162714Z	R:CARBON FIXED CHIP	270 1/16W J TAPE	R371	1
AT371ZHBAE	BRFC162724Z	R:CARBON FIXED CHIP	2.7K 1/16W J TAPE	R074	1
AT371ZHBAE	BRFC162724Z	R:CARBON FIXED CHIP	2.7K 1/16W J TAPE	R407	1
AT371ZHBAE	BRFC162744Z	R:CARBON FIXED CHIP	270K 1/16W J TAPE	R045	1
AT371ZHBAE	BRFC163304Z	R:CARBON FIXED CHIP	33 1/16W J TAPE	R204	1
AT371ZHBAE	BRFC163304Z	R:CARBON FIXED CHIP	33 1/16W J TAPE	R206	1
AT371ZHBAE	BRFC163324Z	R:CARBON FIXED CHIP	3.3K 1/16W J TAPE	R209	1
AT371ZHBAE	BRFC163324Z	R:CARBON FIXED CHIP	3.3K 1/16W J TAPE	R248	1
AT371ZHBAE	BRFC163324Z	R:CARBON FIXED CHIP	3.3K 1/16W J TAPE	R357	1
AT371ZHBAE	BRFC163324Z	R:CARBON FIXED CHIP	3.3K 1/16W J TAPE	R380	1
AT371ZHBAE	BRFC163324Z	R:CARBON FIXED CHIP	3.3K 1/16W J TAPE	R388	1
AT371ZHBAE	BRFC163324Z	R:CARBON FIXED CHIP	3.3K 1/16W J TAPE	R389	1
AT371ZHBAE	BRFC163334Z	R:CARBON FIXED CHIP	33K 1/16W J TAPE	R069	1
AT371ZHBAE	BRFC163334Z	R:CARBON FIXED CHIP	33K 1/16W J TAPE	R217	1
AT371ZHBAE	BRFC163334Z	R:CARBON FIXED CHIP	33K 1/16W J TAPE	R239	1
AT371ZHBAE	BRFC163334Z	R:CARBON FIXED CHIP	33K 1/16W J TAPE	R240	1

MODEL	JHONNY II ASC	TOTAL	674		
ASSY CODE	PARTS CODE	DESCRIPTION	SPEC	REF NO	QTY
AT371ZHBAE	BRFC163334Z	R:CARBON FIXED CHIP	33K 1/16W J TAPE	R255	1
AT371ZHBAE	BRFC163394Z	R:CARBON FIXED CHIP	3.3 1/16W J TAPE	R090	1
AT371ZHBAE	BRFC163394Z	R:CARBON FIXED CHIP	3.3 1/16W J TAPE	R205	1
AT371ZHBAE	BRFC163914Z	R:CARBON FIXED CHIP	390 1/16W J TAPE	R080	1
AT371ZHBAE	BRFC163914Z	R:CARBON FIXED CHIP	390 1/16W J TAPE	R362	1
AT371ZHBAE	BRFC163914Z	R:CARBON FIXED CHIP	390 1/16W J TAPE	R408	1
AT371ZHBAE	BRFC163914Z	R:CARBON FIXED CHIP	390 1/16W J TAPE	R411	1
AT371ZHBAE	BRFC163924Z	R:CARBON FIXED CHIP	3.9K 1/16W J TAPE	R334	1
AT371ZHBAE	BRFC163924Z	R:CARBON FIXED CHIP	3.9K 1/16W J TAPE	R359	1
AT371ZHBAE	BRFC163934Z	R:CARBON FIXED CHIP	39K 1/16W J TAPE	R238	1
AT371ZHBAE	BRFC163934Z	R:CARBON FIXED CHIP	39K 1/16W J TAPE	R249	1
AT371ZHBAE	BRFC163934Z	R:CARBON FIXED CHIP	39K 1/16W J TAPE	R413	1
AT371ZHBAE	BRFC163944Z	R:CARBON FIXED CHIP	390K 1/16W J TAPE	R036	1
AT371ZHBAE	BRFC164704Z	R:CARBON FIXED CHIP	47 1/16W J TAPE	R035	1
AT371ZHBAE	BRFC164704Z	R:CARBON FIXED CHIP	47 1/16W J TAPE	R075	1
AT371ZHBAE	BRFC164714Z	R:CARBON FIXED CHIP	470 1/16W J TAPE	R089	1
AT371ZHBAE	BRFC164714Z	R:CARBON FIXED CHIP	470 1/16W J TAPE	R360	1
AT371ZHBAE	BRFC164714Z	R:CARBON FIXED CHIP	470 1/16W J TAPE	R396	1
AT371ZHBAE	BRFC164724Z	R:CARBON FIXED CHIP	4.7K 1/16W J TAPE	R024	1
AT371ZHBAE	BRFC164724Z	R:CARBON FIXED CHIP	4.7K 1/16W J TAPE	R043	1
AT371ZHBAE	BRFC164724Z	R:CARBON FIXED CHIP	4.7K 1/16W J TAPE	R057	1
AT371ZHBAE	BRFC164724Z	R:CARBON FIXED CHIP	4.7K 1/16W J TAPE	R073	1
AT371ZHBAE	BRFC164724Z	R:CARBON FIXED CHIP	4.7K 1/16W J TAPE	R095	1
AT371ZHBAE	BRFC164724Z	R:CARBON FIXED CHIP	4.7K 1/16W J TAPE	R245	1
AT371ZHBAE	BRFC164724Z	R:CARBON FIXED CHIP	4.7K 1/16W J TAPE	R306	1
AT371ZHBAE	BRFC164724Z	R:CARBON FIXED CHIP	4.7K 1/16W J TAPE	R355	1
AT371ZHBAE	BRFC164734Z	R:CARBON FIXED CHIP	47K 1/16W J TAPE	R023	1
AT371ZHBAE	BRFC164734Z	R:CARBON FIXED CHIP	47K 1/16W J TAPE	R058	1
AT371ZHBAE	BRFC164734Z	R:CARBON FIXED CHIP	47K 1/16W J TAPE	R215	1
AT371ZHBAE	BRFC164734Z	R:CARBON FIXED CHIP	47K 1/16W J TAPE	R259	1
AT371ZHBAE	BRFC164734Z	R:CARBON FIXED CHIP	47K 1/16W J TAPE	R319	1
AT371ZHBAE	BRFC164734Z	R:CARBON FIXED CHIP	47K 1/16W J TAPE	R358	1
AT371ZHBAE	BRFC164734Z	R:CARBON FIXED CHIP	47K 1/16W J TAPE	R361	1
AT371ZHBAE	BRFC164734Z	R:CARBON FIXED CHIP	47K 1/16W J TAPE	R370	1
AT371ZHBAE	BRFC164744Z	R:CARBON FIXED CHIP	470K 1/16W J TAPE	R040	1
AT371ZHBAE	BRFC165604Z	R:CARBON FIXED CHIP	56 1/16W J TAPE	R077	1
AT371ZHBAE	BRFC165604Z	R:CARBON FIXED CHIP	56 1/16W J TAPE	R208	1
AT371ZHBAE	BRFC165604Z	R:CARBON FIXED CHIP	56 1/16W J TAPE	R212	1
AT371ZHBAE	BRFC165614Z	R:CARBON FIXED CHIP	560 1/16W J TAPE	R010	1
AT371ZHBAE	BRFC165614Z	R:CARBON FIXED CHIP	560 1/16W J TAPE	R014	1
AT371ZHBAE	BRFC165614Z	R:CARBON FIXED CHIP	560 1/16W J TAPE	R025	1
AT371ZHBAE	BRFC165614Z	R:CARBON FIXED CHIP	560 1/16W J TAPE	R041	1
AT371ZHBAE	BRFC165614Z	R:CARBON FIXED CHIP	560 1/16W J TAPE	R047	1
AT371ZHBAE	BRFC165614Z	R:CARBON FIXED CHIP	560 1/16W J TAPE	R202	1
AT371ZHBAE	BRFC165624Z	R:CARBON FIXED CHIP	5.6K 1/16W J TAPE	R042	1
AT371ZHBAE	BRFC165624Z	R:CARBON FIXED CHIP	5.6K 1/16W J TAPE	R044	1
AT371ZHBAE	BRFC165624Z	R:CARBON FIXED CHIP	5.6K 1/16W J TAPE	R072	1
AT371ZHBAE	BRFC165624Z	R:CARBON FIXED CHIP	5.6K 1/16W J TAPE	R237	1
AT371ZHBAE	BRFC165624Z	R:CARBON FIXED CHIP	5.6K 1/16W J TAPE	R243	1
AT371ZHBAE	BRFC165624Z	R:CARBON FIXED CHIP	5.6K 1/16W J TAPE	R254	1
AT371ZHBAE	BRFC165624Z	R:CARBON FIXED CHIP	5.6K 1/16W J TAPE	R377	1
AT371ZHBAE	BRFC165624Z	R:CARBON FIXED CHIP	5.6K 1/16W J TAPE	R405	1
AT371ZHBAE	BRFC165634Z	R:CARBON FIXED CHIP	56K 1/16W J TAPE	R037	1
AT371ZHBAE	BRFC165634Z	R:CARBON FIXED CHIP	56K 1/16W J TAPE	R083	1
AT371ZHBAE	BRFC165634Z	R:CARBON FIXED CHIP	56K 1/16W J TAPE	R085	1
AT371ZHBAE	BRFC165644Z	R:CARBON FIXED CHIP	560K 1/16W J TAPE	R064	1
AT371ZHBAE	BRFC165644Z	R:CARBON FIXED CHIP	560K 1/16W J TAPE	R419	1
AT371ZHBAE	BRFC166814Z	R:CARBON FIXED CHIP	680 1/16W J TAPE	R006	1
AT371ZHBAE	BRFC166814Z	R:CARBON FIXED CHIP	680 1/16W J TAPE	R321	1
AT371ZHBAE	BRFC166814Z	R:CARBON FIXED CHIP	680 1/16W J TAPE	R322	1
AT371ZHBAE	BRFC166814Z	R:CARBON FIXED CHIP	680 1/16W J TAPE	R368	1
AT371ZHBAE	BRFC166814Z	R:CARBON FIXED CHIP	680 1/16W J TAPE	R372	1
AT371ZHBAE	BRFC166824Z	R:CARBON FIXED CHIP	6.8K 1/16W J TAPE	R004	1
AT371ZHBAE	BRFC166824Z	R:CARBON FIXED CHIP	6.8K 1/16W J TAPE	R068	1

MODEL	JHONNY II ASC	TOTAL	674		
ASSY CODE	PARTS CODE	DESCRIPTION	SPEC	REF NO	QTY
AT371ZHBAE	BRFC166824Z	R:CARBON FIXED CHIP	6.8K 1/16W J TAPE	R070	1
AT371ZHBAE	BRFC166834Z	R:CARBON FIXED CHIP	68K 1/16W J TAPE	R030	1
AT371ZHBAE	BRFC166834Z	R:CARBON FIXED CHIP	68K 1/16W J TAPE	R409	1
AT371ZHBAE	BRFC166834Z	R:CARBON FIXED CHIP	68K 1/16W J TAPE	R412	1
AT371ZHBAE	BRFC168214Z	R:CARBON FIXED CHIP	820 1/16W J TAPE	R328	1
AT371ZHBAE	BRFC168224Z	R:CARBON FIXED CHIP	8.2K 1/16W J TAPE	R008	1
AT371ZHBAE	BRFC168224Z	R:CARBON FIXED CHIP	8.2K 1/16W J TAPE	R055	1
AT371ZHBAE	BRFC168224Z	R:CARBON FIXED CHIP	8.2K 1/16W J TAPE	R216	1
AT371ZHBAE	BRFC168234Z	R:CARBON FIXED CHIP	82K 1/16W J TAPE	R082	1
AT371ZHBAE	BRFC188204Z	R:CARBON FIXED CHIP	82 1/8W J TAPE	R375	1
AT371ZHBAE	BRFT141034Z	R:CARBON AXIAL LEAD (52)	10K 1/4W J TAPE	R378	1
AT371ZHBAE	BRFT141034Z	R:CARBON AXIAL LEAD (52)	10K 1/4W J TAPE	R398	1
AT371ZHBAE	BRFT141044Z	R:CARBON AXIAL LEAD (52)	100K 1/4W J TAPE	R060	1
AT371ZHBAE	BRPA611034Z	R:CARBON AXIAL LEAD (26)	10K 1/6W J TAPE	R335	1
AT371ZHBAE	BRPA611034Z	R:CARBON AXIAL LEAD (26)	10K 1/6W J TAPE	R338	1
AT371ZHBAE	BRPA611034Z	R:CARBON AXIAL LEAD (26)	10K 1/6W J TAPE	R340	1
AT371ZHBAE	BRPA615614Z	R:CARBON AXIAL LEAD (26)	560 1/6W J TAPE	R232	1
AT371ZHBAE	BRSJ001014Z	R:METAL OXIDE	100 1WS J	R220	1
AT371ZHBAE	BRSJ005604Z	RESISTOR:METAL OXIDE	56 1WS J	R395	1
AT371ZHBAE	BRSJ008204Z	R:METAL OXIDE	82 1WS J	R218	1
AT371ZHBAE	BRSJ008204Z	R:METAL OXIDE	82 1WS J	R219	1
AT371ZHBAE	BRSJ034794Z	RESISTOR:METAL OXIDE	4.7 3WS J	R086	1
AT371ZHBAE	BRTY0569102	R:SEMI-FIXED	RT-569 PVZ3A102A01R00	RT401	1
AT371ZHBAE	BRTY0569103	R:SEMI-FIXED	RT-569 PVZ3A103A01R00	RT201	1
AT371ZHBAE	BRTY0569222	R:SEMI-FIXED	RT-569 PVZ3A222A01R00	RT001	1
AT371ZHBAE	BRTY0569222	R:SEMI-FIXED	RT-569 PVZ3A222A01R00	RT002	1
AT371ZHBAE	BRTY0569222	R:SEMI-FIXED	RT-569 PVZ3A222A01R00	RT202	1
AT371ZHBAE	BRTY0569222	R:SEMI-FIXED	RT-569 PVZ3A222A01R00	RT203	1
AT371ZHBAE	BRTY0569222	R:SEMI-FIXED	RT-569 PVZ3A222A01R00	RT205	1
AT371ZHBAE	BRTY0569472	R:SEMI-FIXED	RT-569 PVZ3A472A01R00	RT206	1
AT371ZHBAE	BTFY0157001	TRANSFORMER:AF CHOKE	TF-157	T301	1
AT371ZHBAE	BTFY0215001	TRANS	TF-215	T302	1
AT371ZHBAE	BTPY0122001	TEST PIN	TP-122 1820-01-PP1	TP001	1
AT371ZHBAM	HHSK352447Z	HEAT SINK (COMP)	C2680(BSP)		1
AT371ZHBAM	HHSK452777Z	HEAT SINK	C2680(BSP)		0
AT371ZHBAM	HHSK452778Z	HEAT SINK	C2680(BSP)		0
AT371ZHBAM	HSDC452454Z	SHIELD CASE	SPT		1
AT371ZHBAW	CUAH014041Z	WIRE	UL1007 #24 10-140- 3 GRY	W001	1
AT371ZHBAW	CUAJ014041Z	WIRE	UL 1007 #24 10-140- 3 WHT	W002	1
AT371ZHBAW	CUPJ003022Z	WIRE W-004	UL 1571 #26 5- 30- 5 WHT	W003	1
AT371ZHBBE	BCML811025Z	C:CERAMIC M/L (1608) TAPE	0.001UF 50V K B	C555	1
AT371ZHBBE	BCML811025Z	C:CERAMIC M/L (1608) TAPE	0.001UF 50V K B	C560	1
AT371ZHBBE	BCML811035Z	C:CERAMIC M/L (1608) TAPE	0.01UF 50V K B	C551	1
AT371ZHBBE	BCML811035Z	C:CERAMIC M/L (1608) TAPE	0.01UF 50V K B	C552	1
AT371ZHBBE	BCML811035Z	C:CERAMIC M/L (1608) TAPE	0.01UF 50V K B	C553	1
AT371ZHBBE	BCML811035Z	C:CERAMIC M/L (1608) TAPE	0.01UF 50V K B	C554	1
AT371ZHBBE	BCML811035Z	C:CERAMIC M/L (1608) TAPE	0.01UF 50V K B	C556	1
AT371ZHBBE	BCML811035Z	C:CERAMIC M/L (1608) TAPE	0.01UF 50V K B	C557	1
AT371ZHBBE	BCML811035Z	C:CERAMIC M/L (1608) TAPE	0.01UF 50V K B	C558	1
AT371ZHBBE	BCML811035Z	C:CERAMIC M/L (1608) TAPE	0.01UF 50V K B	C559	1
AT371ZHBBE	BDAG1261001	DIODE:LED	DA-1261 BD2-40TYG-A12U	D551	1
AT371ZHBBE	BDAY1082015	DIODE:ZENER	UDZS7.5B TE-17	D552	1
AT371ZHBBE	BDAY1082015	DIODE:ZENER	UDZS7.5B TE-17	D553	1
AT371ZHBBE	BDAY1082015	DIODE:ZENER	UDZS7.5B TE-17	D554	1
AT371ZHBBE	BLDY0087001	COIL	LD-087 BF04-3*5*1	L551	1
AT371ZHBBE	BLDY0087001	COIL	LD-087 BF04-3*5*1	L554	1
AT371ZHBBE	BLDY0087001	COIL	LD-087 BF04-3*5*1	L555	1
AT371ZHBBE	BLZY0041100	INDUCTOR:MOLDED	LZ-041 10UH K	L552	1
AT371ZHBBE	BLZY0041100	INDUCTOR:MOLDED	LZ-041 10UH K	L553	1
AT371ZHBBE	BPAG0435AA2	PCB:FRONT	PA-435AA 2/4	B551	1
AT371ZHBBE	BRFC161024Z	R:CARBON FIXED CHIP	1K 1/16W J TAPE	R551	1
AT371ZHBBE	BRFC161024Z	R:CARBON FIXED CHIP	1K 1/16W J TAPE	R552	1
AT371ZHBBE	BRFC161024Z	R:CARBON FIXED CHIP	1K 1/16W J TAPE	R555	1
AT371ZHBBE	BRFC161024Z	R:CARBON FIXED CHIP	1K 1/16W J TAPE	R557	1

MODEL	JHONNY II ASC	TOTAL	674		
ASSY CODE	PARTS CODE	DESCRIPTION	SPEC	REF NO	QTY
AT371ZHBBE	BRFC164724Z	R:CARBON FIXED CHIP	4.7K 1/16W J TAPE	R556	1
AT371ZHBBE	BRFC166824Z	R:CARBON FIXED CHIP	6.8K 1/16W J TAPE	R554	1
AT371ZHBBE	BSWY0557001	SWITCH:SLIDE	SW-557 SSFYP22-14.5B	S551	1
AT371ZHBBE	BSWY0557001	SWITCH:SLIDE	SW-557 SSFYP22-14.5B	S552	1
AT371ZHBBE	BSWY0557001	SWITCH:SLIDE	SW-557 SSFYP22-14.5B	S553	1
AT371ZHBBM	GHDL418694A	HOLDER:LED	ABS BLACK		1
AT371ZHBCE	BCML811035Z	C:CERAMIC M/L (1608) TAPE	0.01UF 50V K B	C701	1
AT371ZHBCE	BCML811035Z	C:CERAMIC M/L (1608) TAPE	0.01UF 50V K B	C702	1
AT371ZHBCE	BPAG0435AA3	PCB:SW	PA-435AA 3/4	B701	1
AT371ZHBCE	BRFC161024Z	R:CARBON FIXED CHIP	1K 1/16W J TAPE	R701	1
AT371ZHBCE	BRFC161024Z	R:CARBON FIXED CHIP	1K 1/16W J TAPE	R702	1
AT371ZHBCE	BSRG0458001	SWITCH:ROTARY	SR-458 SR10030F-30F-F7-008	S701	1
AT371ZHBDE	BPAG0435AA4	PCB:VOLUME	PA-435AA 4/4	B801	1
AT371ZHBDE	BRVY0903001	R:VARIABLE(IP96N00N 25F A503)	RV-903 RY-6467 50KA/S	VR801	1
AT371ZHBDE	CZDZ072065Z	WIRES ASSEMBLED	W-072065	WA801	1
AT371ZHBDE	BDBB1135117	TRANSISTOR	DB-147 2SB1135R	Q503	1
AT371ZHBDE	BDBC2078105	TRANSISTOR	DB-791 2SC2078E	Q501	1
AT371ZHBDE	BDEY0919001	INTEGRATED CIRCUIT	TDA2003V	IC501	1
AT371ZHBDE	BDEY0924001	INTEGRATED CIRCUIT	L7808CV	IC502	1
AT371ZHBDE	BJKY0425002	JACK:W/O LUG	JK-425 M-RM-L 102	J501	1
AT371ZHBDE	BJKY0649001	JACK	JK-649 6S-L113-02A	J502	1
AT371ZHBDE	BRVY0672001	RESISTOR:VARIABLE	RV-672 5KB	VR501	1
AT371ZHBDE	BRVY0672001	RESISTOR:VARIABLE	RV-672 5KB	VR502	1
AT371ZHBDE	BSPY0238001	SPEAKER	SP-238 77R90T0403	SP501	1
AT371ZHBDE	BWZY1105001	CORD:DC CORD	WZ-1105 1500 W/P	WA501	1
AT371ZHBDE	BYDY0019003	BUSHING	YD-019 B312D-11-A	YI503	1
AT371ZHBDE	BYYY0027001	INSULATION SHEET	YY-027	Y501	1
AT371ZHBDE	BYYY0027001	INSULATION SHEET	YY-027	Y502	1
AT371ZHBDE	GCAS2B9975Z	PANEL:FRONT	ABS		1
AT371ZHBDE	GNBC418695Z	KNOB:CHANNEL	ABS,BLACK		1
AT371ZHBDE	GNBY418593A	KNOB	ABS,BLACK		3
AT371ZHBDE	HCAS3B9766Z	COVER:BOTTOM	VINY TOP		1
AT371ZHBDE	HCMT318698C	COVER:TOP	VINYTOP E,0.75T,BLACK		1
AT371ZHBDE	HCSY2B9763Z	CHASSIS	SECC		1
AT371ZHBDE	HHSK4B9767Z	HEAT SINK	A1070P(AL)		1
AT371ZHBDE	HSDC352448Z	SHIELD PLATE	C5210(PBSP)		1
AT371ZHBDE	KDPZ3C0840Z	PLATE:DISPLAY	PC		1
AT371ZHBDE	PLBS459497Z	LABEL:ID	**		1
AT371ZHBDE	PLBS459498Z	LABEL:ID	PAPER		2
AT371ZHBDE	PLBZ474165Z	LABEL:TA	**		1
AT371ZHBDE	PLBZ493436Z	CB STICKER (S)	**		1
AT371ZHBDE	PLBZ493437A	WIRING STICKER	**		1
AT371ZHBDE	PLBZ4B1100Z	LABEL:INDICATION	PAPER		1
AT371ZHBDE	RCUN4B9842Z	CUSHION	NEOPRENE		1
AT371ZHBDE	RCUN4C0269Z	CUSHION	NEOPRENE		1
AT371ZHBDE	RETC490493A	SPACER	WOOL TACK,0.5T,BLACK		2
AT371ZHBDE	RUTC418435Z	WOOL-COATED PAPER:WOOL TACK	WOOL PAPER,100*5*0.3T		4
AT371ZHBDE	SSCW133005N	SCREW:FLAT HD +	M3X5 NI	1	2
AT371ZHBDE	SSCW193008D	SCREW:BIND HD +	M3X8 BZMC	1	4
AT371ZHBDE	SSCW193008N	SCREW:BIND HD +	M3X8 NI	1	1
AT371ZHBDE	SSCW193010N	SCREW:BIND HD +	M3X10 NI	1	5
AT371ZHBDE	SSCW343006D	SCREW:TAPTIGHT BIND HD +	M3X6 BZMC	1	8
AT371ZHBDE	SSCW343006N	SCREW:TAPTIGHT BIND HD +	M3X6 NI	1	4
AT371ZHBDE	SSCW430030N	HEX NUT	M3.0 NI	1	5
AT371ZHBDE	SSCW480030Z	NUT:FLANGE	M3 ZMC	1	4
AT371ZHBDE	TSTD0200003	SPRING PLATE:KNOB	D6.02XL9.53		4
AT371ZHXYE	BMKY0540001	MICROPHONE	MK-540 EMC502-027	MC951	1
AT371ZHXYM	GMSC480407A	SCREW:MOUNTING	ABS,BLACK		2
AT371ZHXYM	HBCT418696A	MOUNTING BRACKET	SPCC 1.2T MFZN3		1
AT371ZHXYM	HMHG402919Z	HANGER:MICROPHONE	SPCC,1.0T,NI		1
AT371ZHXYM	SSCW293508N	SCREW:TAPPING ROUND HD +	D3.5X8 NI	1	2
AT371ZHXYM	SSCW295010N	SCREW:TAPPING ROUND HD +	D5X10 NI	1	2
AT371ZHXYM	SSCW530035N	WASHER:LOCK	D3.5 NI	1	2
AT371ZHXYM	SSCW540050N	WASHER:STAR	D5 NI	1	2

MODEL	JHONNY II ASC	TOTAL	674		
ASSY CODE	PARTS CODE	DESCRIPTION	SPEC	REF NO	QTY
AT371ZHXYM	UTZZ01371ZZ	OWNERS MANUAL	**		1
AT371ZHXYM	VNYL2404080	VINYL BAG	400X400X800X0.07T		0,0833
AT371ZHXYM	VNYL3101500	VINYL BAG	100X150X0.1T		1
AT371ZHXYM	VNYL3102500	VINYL BAG	100X250X0.1T		1
AT371ZHXYM	VNYL3203000	VINYL BAG	200X300X0.1T		2
AT371ZHXYM	WBXZ3C0062Z	DISPLAY BOX	**		1
AT371ZHXYM	WCTZ3C0284A	SHIPPING CARTON BOX	**		0,0833
AT371ZHXYM	WSLV3C0280Z	SLEEVE	**		1
AT371ZHXYM	WSLV4C0278Z	SLEEVE	**		1
AT371ZHXYM	WSLV4C0279Z	SLEEVE	**		1

COMPONENTS LIST

HARRY II Classic

MODEL	HARRY II classic	TOTAL	678		
ASSY CODE	PARTS CODE	DESCRIPTION	SPEC	REF NO	QTY
AT370AHBAE	BCAZ112216Z	C:ELECTROLYTIC	220UF 10V M C-156	C245	1
AT370AHBAE	BCAZ112216Z	C:ELECTROLYTIC	220UF 10V M C-156	C317	1
AT370AHBAE	BCAZ112216Z	C:ELECTROLYTIC	220UF 10V M C-156	C320	1
AT370AHBAE	BCAZ112216Z	C:ELECTROLYTIC	220UF 10V M C-156	C350	1
AT370AHBAE	BCAZ114716Z	C:ELECTROLYTIC	470UF 10V M C-156	C312	1
AT370AHBAE	BCAZ311026Z	C:ELECTROLYTIC	1000UF 16V M C-156	C235	1
AT370AHBAE	BCAZ511026Z	C:ELECTROLYTIC	1000UF 25V M C-156	C315	1
AT370AHBAE	BCAZ514706Z	C:ELECTROLYTIC	47UF 25V M C-156	C030	1
AT370AHBAE	BCAZ514706Z	C:ELECTROLYTIC	47UF 25V M C-156	C031	1
AT370AHBAE	BCAZ514706Z	C:ELECTROLYTIC	47UF 25V M C-156	C044	1
AT370AHBAE	BCAZ514706Z	C:ELECTROLYTIC	47UF 25V M C-156	C047	1
AT370AHBAE	BCAZ514706Z	C:ELECTROLYTIC	47UF 25V M C-156	C065	1
AT370AHBAE	BCAZ514706Z	C:ELECTROLYTIC	47UF 25V M C-156	C253	1
AT370AHBAE	BCAZ514706Z	C:ELECTROLYTIC	47UF 25V M C-156	C310	1
AT370AHBAE	BCAZ514716Z	C:ELECTROLYTIC	470UF 25V M C-156	C043	1
AT370AHBAE	BCAZ811096Z	C:ELECTROLYTIC	1UF 50V M C-156	C011	1
AT370AHBAE	BCAZ812206Z	C:ELECTROLYTIC	22UF 50V M C-156	C366	1
AT370AHBAE	BCAZ814786Z	C:ELECTROLYTIC	0.47UF 50V M C-156	C021	1
AT370AHBAE	BCAZ814796Z	C:ELECTROLYTIC	4.7UF 50V M C-156	C004	1
AT370AHBAE	BCMF111050Z	C:CERAMIC M/L (1608) TAPE	1UF 10V Z F	C036	1
AT370AHBAE	BCMF111050Z	C:CERAMIC M/L (1608) TAPE	1UF 10V Z F	C237	1
AT370AHBAE	BCMF111050Z	C:CERAMIC M/L (1608) TAPE	1UF 10V Z F	C240	1
AT370AHBAE	BCML311045Z	C:CERAMIC M/L (1608) TAPE	0.1UF 16V K B	C023	1
AT370AHBAE	BCML311045Z	C:CERAMIC M/L (1608) TAPE	0.1UF 16V K B	C024	1
AT370AHBAE	BCML311045Z	C:CERAMIC M/L (1608) TAPE	0.1UF 16V K B	C026	1
AT370AHBAE	BCML311045Z	C:CERAMIC M/L (1608) TAPE	0.1UF 16V K B	C027	1
AT370AHBAE	BCML311045Z	C:CERAMIC M/L (1608) TAPE	0.1UF 16V K B	C033	1
AT370AHBAE	BCML311045Z	C:CERAMIC M/L (1608) TAPE	0.1UF 16V K B	C042	1
AT370AHBAE	BCML311045Z	C:CERAMIC M/L (1608) TAPE	0.1UF 16V K B	C045	1
AT370AHBAE	BCML311045Z	C:CERAMIC M/L (1608) TAPE	0.1UF 16V K B	C046	1
AT370AHBAE	BCML311045Z	C:CERAMIC M/L (1608) TAPE	0.1UF 16V K B	C053	1
AT370AHBAE	BCML311045Z	C:CERAMIC M/L (1608) TAPE	0.1UF 16V K B	C055	1
AT370AHBAE	BCML311045Z	C:CERAMIC M/L (1608) TAPE	0.1UF 16V K B	C212	1
AT370AHBAE	BCML311045Z	C:CERAMIC M/L (1608) TAPE	0.1UF 16V K B	C228	1
AT370AHBAE	BCML311045Z	C:CERAMIC M/L (1608) TAPE	0.1UF 16V K B	C230	1
AT370AHBAE	BCML311045Z	C:CERAMIC M/L (1608) TAPE	0.1UF 16V K B	C238	1
AT370AHBAE	BCML311045Z	C:CERAMIC M/L (1608) TAPE	0.1UF 16V K B	C243	1
AT370AHBAE	BCML311045Z	C:CERAMIC M/L (1608) TAPE	0.1UF 16V K B	C247	1
AT370AHBAE	BCML311045Z	C:CERAMIC M/L (1608) TAPE	0.1UF 16V K B	C254	1
AT370AHBAE	BCML311045Z	C:CERAMIC M/L (1608) TAPE	0.1UF 16V K B	C304	1
AT370AHBAE	BCML311045Z	C:CERAMIC M/L (1608) TAPE	0.1UF 16V K B	C306	1
AT370AHBAE	BCML311045Z	C:CERAMIC M/L (1608) TAPE	0.1UF 16V K B	C308	1
AT370AHBAE	BCML311045Z	C:CERAMIC M/L (1608) TAPE	0.1UF 16V K B	C311	1
AT370AHBAE	BCML311045Z	C:CERAMIC M/L (1608) TAPE	0.1UF 16V K B	C319	1
AT370AHBAE	BCML311045Z	C:CERAMIC M/L (1608) TAPE	0.1UF 16V K B	C321	1
AT370AHBAE	BCML311045Z	C:CERAMIC M/L (1608) TAPE	0.1UF 16V K B	C324	1
AT370AHBAE	BCML311045Z	C:CERAMIC M/L (1608) TAPE	0.1UF 16V K B	C325	1
AT370AHBAE	BCML311045Z	C:CERAMIC M/L (1608) TAPE	0.1UF 16V K B	C372	1
AT370AHBAE	BCML311045Z	C:CERAMIC M/L (1608) TAPE	0.1UF 16V K B	C387	1
AT370AHBAE	BCML311045Z	C:CERAMIC M/L (1608) TAPE	0.1UF 16V K B	C388	1
AT370AHBAE	BCML315635Z	C:CERAMIC M/L (1608) TAPE	0.056UF 16V K B	C231	1
AT370AHBAE	BCML811025Z	C:CERAMIC M/L (1608) TAPE	0.001UF 50V K B	C003	1
AT370AHBAE	BCML811025Z	C:CERAMIC M/L (1608) TAPE	0.001UF 50V K B	C005	1
AT370AHBAE	BCML811025Z	C:CERAMIC M/L (1608) TAPE	0.001UF 50V K B	C022	1
AT370AHBAE	BCML811025Z	C:CERAMIC M/L (1608) TAPE	0.001UF 50V K B	C028	1
AT370AHBAE	BCML811025Z	C:CERAMIC M/L (1608) TAPE	0.001UF 50V K B	C032	1
AT370AHBAE	BCML811025Z	C:CERAMIC M/L (1608) TAPE	0.001UF 50V K B	C034	1
AT370AHBAE	BCML811025Z	C:CERAMIC M/L (1608) TAPE	0.001UF 50V K B	C048	1
AT370AHBAE	BCML811025Z	C:CERAMIC M/L (1608) TAPE	0.001UF 50V K B	C049	1

MODEL	HARRY II classic	TOTAL	678		
ASSY CODE	PARTS CODE	DESCRIPTION	SPEC	REF NO	QTY
AT370AHBAE	BCML814735Z	C:CERAMIC M/L (1608) TAPE	0.047UF 50V K B	C020	1
AT370AHBAE	BCML814735Z	C:CERAMIC M/L (1608) TAPE	0.047UF 50V K B	C035	1
AT370AHBAE	BCML814735Z	C:CERAMIC M/L (1608) TAPE	0.047UF 50V K B	C037	1
AT370AHBAE	BCML814735Z	C:CERAMIC M/L (1608) TAPE	0.047UF 50V K B	C038	1
AT370AHBAE	BCML814735Z	C:CERAMIC M/L (1608) TAPE	0.047UF 50V K B	C218	1
AT370AHBAE	BCML814735Z	C:CERAMIC M/L (1608) TAPE	0.047UF 50V K B	C246	1
AT370AHBAE	BCML814735Z	C:CERAMIC M/L (1608) TAPE	0.047UF 50V K B	C250	1
AT370AHBAE	BCML814735Z	C:CERAMIC M/L (1608) TAPE	0.047UF 50V K B	C313	1
AT370AHBAE	BCML814735Z	C:CERAMIC M/L (1608) TAPE	0.047UF 50V K B	C316	1
AT370AHBAE	BCML814735Z	C:CERAMIC M/L (1608) TAPE	0.047UF 50V K B	C330	1
AT370AHBAE	BCMM811002Z	C:CERAMIC M/L (1608) TAPE	10PF 50V D CH	C367	1
AT370AHBAE	BCMM811002Z	C:CERAMIC M/L (1608) TAPE	10PF 50V D CH	C378	1
AT370AHBAE	BCMM811014Z	C:CERAMIC M/L (1608) TAPE	100PF 50V J CH	C006	1
AT370AHBAE	BCMM811214Z	C:CERAMIC M/L (1608) TAPE	120PF 50V J CH	C201	1
AT370AHBAE	BCMM811214Z	C:CERAMIC M/L (1608) TAPE	120PF 50V J CH	C219	1
AT370AHBAE	BCMM811504Z	C:CERAMIC M/L (1608) TAPE	15PF 50V J CH	C213	1
AT370AHBAE	BCMM811514Z	C:CERAMIC M/L (1608) TAPE	150PF 50V J CH	C368	1
AT370AHBAE	BCMM811514Z	C:CERAMIC M/L (1608) TAPE	150PF 50V J CH	C369	1
AT370AHBAE	BCMM811804Z	C:CERAMIC M/L (1608) TAPE	18PF 50V J CH	C203	1
AT370AHBAE	BCMM811804Z	C:CERAMIC M/L (1608) TAPE	18PF 50V J CH	C381	1
AT370AHBAE	BCMM811804Z	C:CERAMIC M/L (1608) TAPE	18PF 50V J CH	C382	1
AT370AHBAE	BCMM811814Z	C:CERAMIC M/L (1608) TAPE	180PF 50V J CH	C204	1
AT370AHBAE	BCMM811814Z	C:CERAMIC M/L (1608) TAPE	180PF 50V J CH	C206	1
AT370AHBAE	BCMM812098Z	C:CERAMIC M/L (1608) TAPE	2PF 50V B CH	C363	1
AT370AHBAE	BCMM812204Z	C:CERAMIC M/L (1608) TAPE	22PF 50V J CH	C001	1
AT370AHBAE	BCMM812204Z	C:CERAMIC M/L (1608) TAPE	22PF 50V J CH	C301	1
AT370AHBAE	BCMM812204Z	C:CERAMIC M/L (1608) TAPE	22PF 50V J CH	C302	1
AT370AHBAE	BCMM812204Z	C:CERAMIC M/L (1608) TAPE	22PF 50V J CH	C380	1
AT370AHBAE	BCMM812214Z	C:CERAMIC M/L (1608) TAPE	220PF 50V J CH	C202	1
AT370AHBAE	BCMM812214Z	C:CERAMIC M/L (1608) TAPE	220PF 50V J CH	C208	1
AT370AHBAE	BCMM812214Z	C:CERAMIC M/L (1608) TAPE	220PF 50V J CH	C223	1
AT370AHBAE	BCMM812704Z	C:CERAMIC M/L (1608) TAPE	27PF 50V J CH	C063	1
AT370AHBAE	BCMM812704Z	C:CERAMIC M/L (1608) TAPE	27PF 50V J CH	C224	1
AT370AHBAE	BCMM813098Z	C:CERAMIC M/L (1608) TAPE	3PF 50V B CH	C007	1
AT370AHBAE	BCMM813314Z	C:CERAMIC M/L (1608) TAPE	330PF 50V J CH	C207	1
AT370AHBAE	BCMM813314Z	C:CERAMIC M/L (1608) TAPE	330PF 50V J CH	C214	1
AT370AHBAE	BCMM813904Z	C:CERAMIC M/L (1608) TAPE	39PF 50V J CH	C215	1
AT370AHBAE	BCMM813904Z	C:CERAMIC M/L (1608) TAPE	39PF 50V J CH	C322	1
AT370AHBAE	BCMM814704Z	C:CERAMIC M/L (1608) TAPE	47PF 50V J CH	C041	1
AT370AHBAE	BCMM815091Z	C:CERAMIC M/L (1608) TAPE	5PF 50V C CH	C226	1
AT370AHBAE	BCMM815604Z	C:CERAMIC M/L (1608) TAPE	56PF 50V J CH	C361	1
AT370AHBAE	BCMM815614Z	C:CERAMIC M/L (1608) TAPE	560PF 50V J CH	C015	1
AT370AHBAE	BCMM816804Z	C:CERAMIC M/L (1608) TAPE	68PF 50V J CH	C259	1
AT370AHBAE	BCMM816814Z	C:CERAMIC M/L (1608) TAPE	680PF 50V J CH	C232	1
AT370AHBAE	BCMM818204Z	C:CERAMIC M/L (1608) TAPE	82PF 50V J CH	C210	1
AT370AHBAE	BCMS812091Z	C:CERAMIC M/L (1608) TAPE	2PF 50V C CK	C209	1
AT370AHBAE	BCSH464796Z	C:TANTALUM CHIP TAPE	4.7UF 20V M A C-122	C040	1
AT370AHBAE	BCSH514786Z	C:TANTALUM CHIP TAPE	0.47UF 25V M C-122 TAPE	C376	1
AT370AHBAE	BCSH661086Z	CAPACITOR:TANTALUM CHIP	0.1UF 35V M C-122 TAPE	C375	1
AT370AHBAE	BCTY0090500	C:TRIMMER	CT-090 ECR-LA050M52 50PF	CT301	1
AT370AHBAE	BDAY0808001	DIODE:SWITCHING	1SS356 TW11	D001	1
AT370AHBAE	BDAY0808001	DIODE:SWITCHING	1SS356 TW11	D002	1
AT370AHBAE	BDAY0811001	DIODE	SB340	D304	1
AT370AHBAE	BDAY0940001	DIODE:VARICAP	HVU307 TRU	D207	1
AT370AHBAE	BDAY0940001	DIODE:VARICAP	HVU307 TRU	D362	1
AT370AHBAE	BDAY0940001	DIODE:VARICAP	HVU307 TRU	D363	1
AT370AHBAE	BDAY0993001	DIODE	KDS160E-RTK	D003	1
AT370AHBAE	BDAY0993001	DIODE	KDS160E-RTK	D004	1
AT370AHBAE	BDAY0993001	DIODE	KDS160E-RTK	D005	1
AT370AHBAE	BDAY0993001	DIODE	KDS160E-RTK	D006	1
AT370AHBAE	BDAY0993001	DIODE	KDS160E-RTK	D007	1

MODEL	HARRY II classic	TOTAL	678		
ASSY CODE	PARTS CODE	DESCRIPTION	SPEC	REF NO	QTY
AT370AHBAE	BDAY0993001	DIODE	KDS160E-RTK	D008	1
AT370AHBAE	BDAY0993001	DIODE	KDS160E-RTK	D009	1
AT370AHBAE	BDAY0993001	DIODE	KDS160E-RTK	D011	1
AT370AHBAE	BDAY0993001	DIODE	KDS160E-RTK	D201	1
AT370AHBAE	BDAY0993001	DIODE	KDS160E-RTK	D202	1
AT370AHBAE	BDAY0993001	DIODE	KDS160E-RTK	D203	1
AT370AHBAE	BDAY0993001	DIODE	KDS160E-RTK	D205	1
AT370AHBAE	BDAY0993001	DIODE	KDS160E-RTK	D302	1
AT370AHBAE	BDAY0993001	DIODE	KDS160E-RTK	D307	1
AT370AHBAE	BDAY0993001	DIODE	KDS160E-RTK	D308	1
AT370AHBAE	BDAY0993001	DIODE	KDS160E-RTK	D309	1
AT370AHBAE	BDAY0993001	DIODE	KDS160E-RTK	D311	1
AT370AHBAE	BDAY1082004	DIODE:ZENER	UDZS5.1B TE-17	D306	1
AT370AHBAE	BDAY1082004	DIODE:ZENER	UDZS5.1B TE-17	D361	1
AT370AHBAE	BDAY1082013	DIODE:ZENER	UDZS5.6B TE-17	D010	1
AT370AHBAE	BDAY1082015	DIODE:ZENER	UDZS7.5B TE-17	D301	1
AT370AHBAE	BDAY1082016	DIODE:ZENER	UDZS3.0B TE-17	D206	1
AT370AHBAE	BDAY1185001	DIODE	GD 1N4003-A2	D204	1
AT370AHBAE	BDBA1235106	TRANSISTOR	DB-092 2SA1235A-T12-1F	Q212	1
AT370AHBAE	BDBA1235106	TRANSISTOR	DB-092 2SA1235A-T12-1F	Q215	1
AT370AHBAE	BDBA1235106	TRANSISTOR	DB-092 2SA1235A-T12-1F	Q306	1
AT370AHBAE	BDBA1235106	TRANSISTOR	DB-092 2SA1235A-T12-1F	Q307	1
AT370AHBAE	BDBA1235106	TRANSISTOR	DB-092 2SA1235A-T12-1F	Q311	1
AT370AHBAE	BDBA1235106	TRANSISTOR	DB-092 2SA1235A-T12-1F	Q313	1
AT370AHBAE	BDBC0941523	TRANSISTOR	DB-301 2SC941TM-O	Q202	1
AT370AHBAE	BDBC2314106	TRANSISTOR	DB-792 2SC2314F	Q201	1
AT370AHBAE	BDBC2714124	TRANSISTOR	DB-718 2SC2714-Y TE85L	Q001	1
AT370AHBAE	BDBC2714124	TRANSISTOR	DB-718 2SC2714-Y TE85L	Q004	1
AT370AHBAE	BDBC2714124	TRANSISTOR	DB-718 2SC2714-Y TE85L	Q005	1
AT370AHBAE	BDBC2714124	TRANSISTOR	DB-718 2SC2714-Y TE85L	Q013	1
AT370AHBAE	BDBC2714124	TRANSISTOR	DB-718 2SC2714-Y TE85L	Q203	1
AT370AHBAE	BDBC2714124	TRANSISTOR	DB-718 2SC2714-Y TE85L	Q302	1
AT370AHBAE	BDBC2714124	TRANSISTOR	DB-718 2SC2714-Y TE85L	Q303	1
AT370AHBAE	BDBC3052106	TRANSISTOR	DB-862 2SC3052-T12-1F	Q006	1
AT370AHBAE	BDBC3052106	TRANSISTOR	DB-862 2SC3052-T12-1F	Q007	1
AT370AHBAE	BDBC3052106	TRANSISTOR	DB-862 2SC3052-T12-1F	Q008	1
AT370AHBAE	BDBC3052106	TRANSISTOR	DB-862 2SC3052-T12-1F	Q009	1
AT370AHBAE	BDBC3052106	TRANSISTOR	DB-862 2SC3052-T12-1F	Q011	1
AT370AHBAE	BDBC3052106	TRANSISTOR	DB-862 2SC3052-T12-1F	Q012	1
AT370AHBAE	BDBC3052106	TRANSISTOR	DB-862 2SC3052-T12-1F	Q014	1
AT370AHBAE	BDBC3052106	TRANSISTOR	DB-862 2SC3052-T12-1F	Q207	1
AT370AHBAE	BDBC3052106	TRANSISTOR	DB-862 2SC3052-T12-1F	Q208	1
AT370AHBAE	BDBC3052106	TRANSISTOR	DB-862 2SC3052-T12-1F	Q211	1
AT370AHBAE	BDBC3052106	TRANSISTOR	DB-862 2SC3052-T12-1F	Q213	1
AT370AHBAE	BDBC3052106	TRANSISTOR	DB-862 2SC3052-T12-1F	Q216	1
AT370AHBAE	BDBC3052106	TRANSISTOR	DB-862 2SC3052-T12-1F	Q301	1
AT370AHBAE	BDBC3052106	TRANSISTOR	DB-862 2SC3052-T12-1F	Q309	1
AT370AHBAE	BDBC3052106	TRANSISTOR	DB-862 2SC3052-T12-1F	Q312	1
AT370AHBAE	BDBC3052106	TRANSISTOR	DB-862 2SC3052-T12-1F	Q314	1
AT370AHBAE	BDBC3243105	TRANSISTOR	DB-867 2SC3243-T11-E	Q209	1
AT370AHBAE	BDBC3243105	TRANSISTOR	DB-867 2SC3243-T11-E	Q308	1
AT370AHBAE	BDBC5065124	TRANSISTOR	DB-848 2SC5065-Y(TE85R)	Q304	1
AT370AHBAE	BDBD1048661	TRANSISTOR	DB-435 2SD1048-X6 TB	Q010	1
AT370AHBAE	BDBD1048661	TRANSISTOR	DB-435 2SD1048-X6 TB	Q214	1
AT370AHBAE	BDBD1048661	TRANSISTOR	DB-435 2SD1048-X6 TB	Q305	1
AT370AHBAE	BDCB0210301	FIELD EFFECT TRANSISTOR	DC-022 2SK210-BL TE85L	Q002	1
AT370AHBAE	BDCB0210301	FIELD EFFECT TRANSISTOR	DC-022 2SK210-BL TE85L	Q003	1
AT370AHBAE	BDDG1515001	INTEGRATED CIRCUIT:UC2971	UPD780021AGB-G26-8EU-A	IC301	1
AT370AHBAE	BDEG4222003	INTEGRATED CIRCUIT	TK83361MTL-G	IC001	1
AT370AHBAE	BDEG4251003	INTEGRATED CIRCUIT	RH5RL50AA-T1-FA	IC304	1
AT370AHBAE	BDEY2769003	INTEGRATED CIRCUIT	BU2630F-E2	IC306	1

MODEL	HARRY II classic	TOTAL	678		
ASSY CODE	PARTS CODE	DESCRIPTION	SPEC	REF NO	QTY
AT370AHBAE	BDEY3654003	INTEGRATED CIRCUIT	NJM12904M-TE3--#ZZZB	IC002	1
AT370AHBAE	BDEY3654003	INTEGRATED CIRCUIT	NJM12904M-TE3--#ZZZB	IC201	1
AT370AHBAE	BDEY3654003	INTEGRATED CIRCUIT	NJM12904M-TE3--#ZZZB	IC202	1
AT370AHBAE	BDEY3664003	INTEGRATED CIRCUIT	S-24CC02A-J8T1	IC302	1
AT370AHBAE	BDEY4017003	INTEGRATED CIRCUIT	XC61CC4302PR/XC61AC4302PR	IC303	1
AT370AHBAE	BFLY0055001	FILTER:CRYSTAL	FL-055 10M07AZ	FT001	1
AT370AHBAE	BFLY0852001	FILTER:CERAMIC	FL-852 LTS455HTW	FT002	1
AT370AHBAE	BJKG1249003	JACK	JK-1249 IMSA-9210B-1-03Z058-PT1	J004	1
AT370AHBAE	BJKY0899001	JACK:EARPHONE	JK-899 JH3501-020D	J003	1
AT370AHBAE	BLBG1226001	COIL	LB-1226 KY1107R	L360	1
AT370AHBAE	BLBG1226001	COIL	LB-1226 KY1107R	L361	1
AT370AHBAE	BLBG1227001	COIL	LB-1227 KS2553N	L003	1
AT370AHBAE	BLBY1120001	COIL	LB-1120 KS2482AC	L004	1
AT370AHBAE	BLBY1129001	COIL	LB-1129 7PL4A151N	L006	1
AT370AHBAE	BLBY1131001	COIL	LB-1131 KS2484F	L001	1
AT370AHBAE	BLBY1153001	COIL	LB-1153 KS2485NC	L002	1
AT370AHBAE	BLBY1175001	COIL	LB-1175 7002BE-A0026HM	L009	1
AT370AHBAE	BLBY1179001	COIL	LB-1179 7MK4A033N	L007	1
AT370AHBAE	BLCY0255001	COIL	LC-255 MD146-08F42	L205	1
AT370AHBAE	BLDY0087001	COIL	LD-087 BF04-3*5*1	L010	1
AT370AHBAE	BLDY0087001	COIL	LD-087 BF04-3*5*1	L011	1
AT370AHBAE	BLDY0087001	COIL	LD-087 BF04-3*5*1	L207	1
AT370AHBAE	BLDY0087001	COIL	LD-087 BF04-3*5*1	L209	1
AT370AHBAE	BLDY0087001	COIL	LD-087 BF04-3*5*1	L211	1
AT370AHBAE	BLDY0252001	COIL	LD-252 3A1737RH	L206	1
AT370AHBAE	BLDY0252001	COIL	LD-252 3A1737RH	L301	1
AT370AHBAE	BLDY0252001	COIL	LD-252 3A1737RH	L302	1
AT370AHBAE	BLEY0475001	COIL	LE-475 AC1979	L201	1
AT370AHBAE	BLEY0475001	COIL	LE-475 AC1979	L204	1
AT370AHBAE	BLEY0486001	COIL	LE-486 AC1973	L202	1
AT370AHBAE	BLEY0486001	COIL	LE-486 AC1973	L203	1
AT370AHBAE	BLEY0535001	COIL	LE-535	L208	1
AT370AHBAE	BLZY0041338	INDUCTOR:MOLED	LZ-041 0.33UH K	L210	1
AT370AHBAE	BPAG0435AA1	PCB:MAIN	PA-435AA 1/4	B001	1
AT370AHBAE	BPGG0185001	PLUG	PG-185 IMSA-9215H-T	PG001	1
AT370AHBAE	BQXY0074001	CRYSTAL	QX-074 10.240MHZ	X302	1
AT370AHBAE	BQXY0796001	CRYSTAL	QX-796 4.258996MHZ	X301	1
AT370AHBAE	BRFC160004Z	R:CARBON FIXED CHIP	0 1/16W J TAPE	R017	1
AT370AHBAE	BRFC160004Z	R:CARBON FIXED CHIP	0 1/16W J TAPE	R400	1
AT370AHBAE	BRFC161004Z	R:CARBON FIXED CHIP	10 1/16W J TAPE	R015	1
AT370AHBAE	BRFC161014Z	R:CARBON FIXED CHIP	100 1/16W J TAPE	R007	1
AT370AHBAE	BRFC161014Z	R:CARBON FIXED CHIP	100 1/16W J TAPE	R012	1
AT370AHBAE	BRFC161014Z	R:CARBON FIXED CHIP	100 1/16W J TAPE	R019	1
AT370AHBAE	BRFC161014Z	R:CARBON FIXED CHIP	100 1/16W J TAPE	R026	1
AT370AHBAE	BRFC161014Z	R:CARBON FIXED CHIP	100 1/16W J TAPE	R067	1
AT370AHBAE	BRFC161014Z	R:CARBON FIXED CHIP	100 1/16W J TAPE	R087	1
AT370AHBAE	BRFC161014Z	R:CARBON FIXED CHIP	100 1/16W J TAPE	R203	1
AT370AHBAE	BRFC161024Z	R:CARBON FIXED CHIP	1K 1/16W J TAPE	R002	1
AT370AHBAE	BRFC161024Z	R:CARBON FIXED CHIP	1K 1/16W J TAPE	R016	1
AT370AHBAE	BRFC161024Z	R:CARBON FIXED CHIP	1K 1/16W J TAPE	R236	1
AT370AHBAE	BRFC161024Z	R:CARBON FIXED CHIP	1K 1/16W J TAPE	R244	1
AT370AHBAE	BRFC161024Z	R:CARBON FIXED CHIP	1K 1/16W J TAPE	R246	1
AT370AHBAE	BRFC161024Z	R:CARBON FIXED CHIP	1K 1/16W J TAPE	R301	1
AT370AHBAE	BRFC161024Z	R:CARBON FIXED CHIP	1K 1/16W J TAPE	R303	1
AT370AHBAE	BRFC161024Z	R:CARBON FIXED CHIP	1K 1/16W J TAPE	R304	1
AT370AHBAE	BRFC161024Z	R:CARBON FIXED CHIP	1K 1/16W J TAPE	R305	1
AT370AHBAE	BRFC161024Z	R:CARBON FIXED CHIP	1K 1/16W J TAPE	R318	1
AT370AHBAE	BRFC161024Z	R:CARBON FIXED CHIP	1K 1/16W J TAPE	R324	1
AT370AHBAE	BRFC161024Z	R:CARBON FIXED CHIP	1K 1/16W J TAPE	R325	1
AT370AHBAE	BRFC161024Z	R:CARBON FIXED CHIP	1K 1/16W J TAPE	R327	1
AT370AHBAE	BRFC161024Z	R:CARBON FIXED CHIP	1K 1/16W J TAPE	R346	1

MODEL	HARRY II classic	TOTAL	678		
ASSY CODE	PARTS CODE	DESCRIPTION	SPEC	REF NO	QTY
AT370AHBAE	BRFC161044Z	R:CARBON FIXED CHIP	100K 1/16W J TAPE	R059	1
AT370AHBAE	BRFC161044Z	R:CARBON FIXED CHIP	100K 1/16W J TAPE	R061	1
AT370AHBAE	BRFC161044Z	R:CARBON FIXED CHIP	100K 1/16W J TAPE	R348	1
AT370AHBAE	BRFC161054Z	R:CARBON FIXED CHIP	1M 1/16W J TAPE	R038	1
AT370AHBAE	BRFC161054Z	R:CARBON FIXED CHIP	1M 1/16W J TAPE	R039	1
AT370AHBAE	BRFC161054Z	R:CARBON FIXED CHIP	1M 1/16W J TAPE	R046	1
AT370AHBAE	BRFC161054Z	R:CARBON FIXED CHIP	1M 1/16W J TAPE	R326	1
AT370AHBAE	BRFC161054Z	R:CARBON FIXED CHIP	1M 1/16W J TAPE	R329	1
AT370AHBAE	BRFC161054Z	R:CARBON FIXED CHIP	1M 1/16W J TAPE	R336	1
AT370AHBAE	BRFC161514Z	R:CARBON FIXED CHIP	150 1/16W J TAPE	R022	1
AT370AHBAE	BRFC161514Z	R:CARBON FIXED CHIP	150 1/16W J TAPE	R028	1
AT370AHBAE	BRFC161514Z	R:CARBON FIXED CHIP	150 1/16W J TAPE	R252	1
AT370AHBAE	BRFC161524Z	R:CARBON FIXED CHIP	1.5K 1/16W J TAPE	R065	1
AT370AHBAE	BRFC161524Z	R:CARBON FIXED CHIP	1.5K 1/16W J TAPE	R091	1
AT370AHBAE	BRFC161524Z	R:CARBON FIXED CHIP	1.5K 1/16W J TAPE	R221	1
AT370AHBAE	BRFC161524Z	R:CARBON FIXED CHIP	1.5K 1/16W J TAPE	R233	1
AT370AHBAE	BRFC161524Z	R:CARBON FIXED CHIP	1.5K 1/16W J TAPE	R247	1
AT370AHBAE	BRFC161524Z	R:CARBON FIXED CHIP	1.5K 1/16W J TAPE	R376	1
AT370AHBAE	BRFC161534Z	R:CARBON FIXED CHIP	15K 1/16W J TAPE	R021	1
AT370AHBAE	BRFC161534Z	R:CARBON FIXED CHIP	15K 1/16W J TAPE	R033	1
AT370AHBAE	BRFC161534Z	R:CARBON FIXED CHIP	15K 1/16W J TAPE	R092	1
AT370AHBAE	BRFC161544Z	R:CARBON FIXED CHIP	150K 1/16W J TAPE	R034	1
AT370AHBAE	BRFC161554Z	R:CARBON FIXED CHIP	1.5M 1/16W J TAPE	R071	1
AT370AHBAE	BRFC161824Z	R:CARBON FIXED CHIP	1.8K 1/16W J TAPE	R013	1
AT370AHBAE	BRFC161824Z	R:CARBON FIXED CHIP	1.8K 1/16W J TAPE	R210	1
AT370AHBAE	BRFC162204Z	R:CARBON FIXED CHIP	22 1/16W J TAPE	R207	1
AT370AHBAE	BRFC162214Z	R:CARBON FIXED CHIP	220 1/16W J TAPE	R018	1
AT370AHBAE	BRFC162214Z	R:CARBON FIXED CHIP	220 1/16W J TAPE	R080	1
AT370AHBAE	BRFC162214Z	R:CARBON FIXED CHIP	220 1/16W J TAPE	R084	1
AT370AHBAE	BRFC162214Z	R:CARBON FIXED CHIP	220 1/16W J TAPE	R088	1
AT370AHBAE	BRFC162214Z	R:CARBON FIXED CHIP	220 1/16W J TAPE	R094	1
AT370AHBAE	BRFC162214Z	R:CARBON FIXED CHIP	220 1/16W J TAPE	R211	1
AT370AHBAE	BRFC162214Z	R:CARBON FIXED CHIP	220 1/16W J TAPE	R214	1
AT370AHBAE	BRFC162214Z	R:CARBON FIXED CHIP	220 1/16W J TAPE	R363	1
AT370AHBAE	BRFC162224Z	R:CARBON FIXED CHIP	2.2K 1/16W J TAPE	R003	1
AT370AHBAE	BRFC162224Z	R:CARBON FIXED CHIP	2.2K 1/16W J TAPE	R005	1
AT370AHBAE	BRFC162224Z	R:CARBON FIXED CHIP	2.2K 1/16W J TAPE	R020	1
AT370AHBAE	BRFC162224Z	R:CARBON FIXED CHIP	2.2K 1/16W J TAPE	R027	1
AT370AHBAE	BRFC162224Z	R:CARBON FIXED CHIP	2.2K 1/16W J TAPE	R226	1
AT370AHBAE	BRFC162224Z	R:CARBON FIXED CHIP	2.2K 1/16W J TAPE	R229	1
AT370AHBAE	BRFC162224Z	R:CARBON FIXED CHIP	2.2K 1/16W J TAPE	R231	1
AT370AHBAE	BRFC162224Z	R:CARBON FIXED CHIP	2.2K 1/16W J TAPE	R235	1
AT370AHBAE	BRFC162224Z	R:CARBON FIXED CHIP	2.2K 1/16W J TAPE	R251	1
AT370AHBAE	BRFC162224Z	R:CARBON FIXED CHIP	2.2K 1/16W J TAPE	R253	1
AT370AHBAE	BRFC162224Z	R:CARBON FIXED CHIP	2.2K 1/16W J TAPE	R260	1
AT370AHBAE	BRFC162224Z	R:CARBON FIXED CHIP	2.2K 1/16W J TAPE	R261	1
AT370AHBAE	BRFC162224Z	R:CARBON FIXED CHIP	2.2K 1/16W J TAPE	R262	1
AT370AHBAE	BRFC162224Z	R:CARBON FIXED CHIP	2.2K 1/16W J TAPE	R300	1
AT370AHBAE	BRFC162224Z	R:CARBON FIXED CHIP	2.2K 1/16W J TAPE	R302	1
AT370AHBAE	BRFC162224Z	R:CARBON FIXED CHIP	2.2K 1/16W J TAPE	R320	1
AT370AHBAE	BRFC162224Z	R:CARBON FIXED CHIP	2.2K 1/16W J TAPE	R323	1
AT370AHBAE	BRFC162224Z	R:CARBON FIXED CHIP	2.2K 1/16W J TAPE	R330	1
AT370AHBAE	BRFC162224Z	R:CARBON FIXED CHIP	2.2K 1/16W J TAPE	R331	1
AT370AHBAE	BRFC162224Z	R:CARBON FIXED CHIP	2.2K 1/16W J TAPE	R332	1
AT370AHBAE	BRFC162234Z	R:CARBON FIXED CHIP	22K 1/16W J TAPE	R049	1
AT370AHBAE	BRFC162234Z	R:CARBON FIXED CHIP	22K 1/16W J TAPE	R213	1
AT370AHBAE	BRFC162234Z	R:CARBON FIXED CHIP	22K 1/16W J TAPE	R345	1
AT370AHBAE	BRFC162234Z	R:CARBON FIXED CHIP	22K 1/16W J TAPE	R364	1
AT370AHBAE	BRFC162244Z	R:CARBON FIXED CHIP	220K 1/16W J TAPE	R234	1
AT370AHBAE	BRFC162254Z	R:CARBON FIXED CHIP	2.2M 1/16W J TAPE	R056	1
AT370AHBAE	BRFC162294Z	R:CARBON FIXED CHIP	2.2 1/16W J TAPE	R076	1

MODEL	HARRY II classic	TOTAL	678		
ASSY CODE	PARTS CODE	DESCRIPTION	SPEC	REF NO	QTY
AT370AHBAE	BRFC162714Z	R:CARBON FIXED CHIP	270 1/16W J TAPE	R009	1
AT370AHBAE	BRFC162714Z	R:CARBON FIXED CHIP	270 1/16W J TAPE	R011	1
AT370AHBAE	BRFC162714Z	R:CARBON FIXED CHIP	270 1/16W J TAPE	R309	1
AT370AHBAE	BRFC162714Z	R:CARBON FIXED CHIP	270 1/16W J TAPE	R310	1
AT370AHBAE	BRFC162714Z	R:CARBON FIXED CHIP	270 1/16W J TAPE	R311	1
AT370AHBAE	BRFC162714Z	R:CARBON FIXED CHIP	270 1/16W J TAPE	R312	1
AT370AHBAE	BRFC162714Z	R:CARBON FIXED CHIP	270 1/16W J TAPE	R313	1
AT370AHBAE	BRFC162714Z	R:CARBON FIXED CHIP	270 1/16W J TAPE	R314	1
AT370AHBAE	BRFC162714Z	R:CARBON FIXED CHIP	270 1/16W J TAPE	R315	1
AT370AHBAE	BRFC162714Z	R:CARBON FIXED CHIP	270 1/16W J TAPE	R316	1
AT370AHBAE	BRFC162714Z	R:CARBON FIXED CHIP	270 1/16W J TAPE	R371	1
AT370AHBAE	BRFC162724Z	R:CARBON FIXED CHIP	2.7K 1/16W J TAPE	R074	1
AT370AHBAE	BRFC162744Z	R:CARBON FIXED CHIP	270K 1/16W J TAPE	R045	1
AT370AHBAE	BRFC163304Z	R:CARBON FIXED CHIP	33 1/16W J TAPE	R204	1
AT370AHBAE	BRFC163304Z	R:CARBON FIXED CHIP	33 1/16W J TAPE	R206	1
AT370AHBAE	BRFC163314Z	R:CARBON FIXED CHIP	330 1/16W J TAPE	R230	1
AT370AHBAE	BRFC163324Z	R:CARBON FIXED CHIP	3.3K 1/16W J TAPE	R062	1
AT370AHBAE	BRFC163324Z	R:CARBON FIXED CHIP	3.3K 1/16W J TAPE	R066	1
AT370AHBAE	BRFC163324Z	R:CARBON FIXED CHIP	3.3K 1/16W J TAPE	R209	1
AT370AHBAE	BRFC163324Z	R:CARBON FIXED CHIP	3.3K 1/16W J TAPE	R248	1
AT370AHBAE	BRFC163324Z	R:CARBON FIXED CHIP	3.3K 1/16W J TAPE	R357	1
AT370AHBAE	BRFC163324Z	R:CARBON FIXED CHIP	3.3K 1/16W J TAPE	R380	1
AT370AHBAE	BRFC163324Z	R:CARBON FIXED CHIP	3.3K 1/16W J TAPE	R388	1
AT370AHBAE	BRFC163324Z	R:CARBON FIXED CHIP	3.3K 1/16W J TAPE	R389	1
AT370AHBAE	BRFC163334Z	R:CARBON FIXED CHIP	33K 1/16W J TAPE	R051	1
AT370AHBAE	BRFC163334Z	R:CARBON FIXED CHIP	33K 1/16W J TAPE	R069	1
AT370AHBAE	BRFC163334Z	R:CARBON FIXED CHIP	33K 1/16W J TAPE	R217	1
AT370AHBAE	BRFC163334Z	R:CARBON FIXED CHIP	33K 1/16W J TAPE	R239	1
AT370AHBAE	BRFC163334Z	R:CARBON FIXED CHIP	33K 1/16W J TAPE	R240	1
AT370AHBAE	BRFC163334Z	R:CARBON FIXED CHIP	33K 1/16W J TAPE	R255	1
AT370AHBAE	BRFC163394Z	R:CARBON FIXED CHIP	3.3 1/16W J TAPE	R090	1
AT370AHBAE	BRFC163394Z	R:CARBON FIXED CHIP	3.3 1/16W J TAPE	R205	1
AT370AHBAE	BRFC163914Z	R:CARBON FIXED CHIP	390 1/16W J TAPE	R223	1
AT370AHBAE	BRFC163914Z	R:CARBON FIXED CHIP	390 1/16W J TAPE	R362	1
AT370AHBAE	BRFC163924Z	R:CARBON FIXED CHIP	3.9K 1/16W J TAPE	R334	1
AT370AHBAE	BRFC163924Z	R:CARBON FIXED CHIP	3.9K 1/16W J TAPE	R347	1
AT370AHBAE	BRFC163924Z	R:CARBON FIXED CHIP	3.9K 1/16W J TAPE	R359	1
AT370AHBAE	BRFC163934Z	R:CARBON FIXED CHIP	39K 1/16W J TAPE	R238	1
AT370AHBAE	BRFC163934Z	R:CARBON FIXED CHIP	39K 1/16W J TAPE	R249	1
AT370AHBAE	BRFC163944Z	R:CARBON FIXED CHIP	390K 1/16W J TAPE	R036	1
AT370AHBAE	BRFC164704Z	R:CARBON FIXED CHIP	47 1/16W J TAPE	R035	1
AT370AHBAE	BRFC164704Z	R:CARBON FIXED CHIP	47 1/16W J TAPE	R075	1
AT370AHBAE	BRFC164714Z	R:CARBON FIXED CHIP	470 1/16W J TAPE	R089	1
AT370AHBAE	BRFC164714Z	R:CARBON FIXED CHIP	470 1/16W J TAPE	R360	1
AT370AHBAE	BRFC164714Z	R:CARBON FIXED CHIP	470 1/16W J TAPE	R396	1
AT370AHBAE	BRFC164724Z	R:CARBON FIXED CHIP	4.7K 1/16W J TAPE	R024	1
AT370AHBAE	BRFC164724Z	R:CARBON FIXED CHIP	4.7K 1/16W J TAPE	R043	1
AT370AHBAE	BRFC164724Z	R:CARBON FIXED CHIP	4.7K 1/16W J TAPE	R057	1
AT370AHBAE	BRFC164724Z	R:CARBON FIXED CHIP	4.7K 1/16W J TAPE	R073	1
AT370AHBAE	BRFC164724Z	R:CARBON FIXED CHIP	4.7K 1/16W J TAPE	R095	1
AT370AHBAE	BRFC164724Z	R:CARBON FIXED CHIP	4.7K 1/16W J TAPE	R245	1
AT370AHBAE	BRFC164724Z	R:CARBON FIXED CHIP	4.7K 1/16W J TAPE	R306	1
AT370AHBAE	BRFC164724Z	R:CARBON FIXED CHIP	4.7K 1/16W J TAPE	R355	1
AT370AHBAE	BRFC164734Z	R:CARBON FIXED CHIP	47K 1/16W J TAPE	R023	1
AT370AHBAE	BRFC164734Z	R:CARBON FIXED CHIP	47K 1/16W J TAPE	R058	1
AT370AHBAE	BRFC164734Z	R:CARBON FIXED CHIP	47K 1/16W J TAPE	R215	1
AT370AHBAE	BRFC164734Z	R:CARBON FIXED CHIP	47K 1/16W J TAPE	R259	1
AT370AHBAE	BRFC164734Z	R:CARBON FIXED CHIP	47K 1/16W J TAPE	R319	1
AT370AHBAE	BRFC164734Z	R:CARBON FIXED CHIP	47K 1/16W J TAPE	R354	1
AT370AHBAE	BRFC164734Z	R:CARBON FIXED CHIP	47K 1/16W J TAPE	R358	1
AT370AHBAE	BRFC164734Z	R:CARBON FIXED CHIP	47K 1/16W J TAPE	R361	1

MODEL	HARRY II classic	TOTAL	678		
ASSY CODE	PARTS CODE	DESCRIPTION	SPEC	REF NO	QTY
AT370AHBAE	BRFC164734Z	R:CARBON FIXED CHIP	47K 1/16W J TAPE	R370	1
AT370AHBAE	BRFC164744Z	R:CARBON FIXED CHIP	470K 1/16W J TAPE	R040	1
AT370AHBAE	BRFC165604Z	R:CARBON FIXED CHIP	56 1/16W J TAPE	R077	1
AT370AHBAE	BRFC165604Z	R:CARBON FIXED CHIP	56 1/16W J TAPE	R093	1
AT370AHBAE	BRFC165604Z	R:CARBON FIXED CHIP	56 1/16W J TAPE	R208	1
AT370AHBAE	BRFC165604Z	R:CARBON FIXED CHIP	56 1/16W J TAPE	R212	1
AT370AHBAE	BRFC165614Z	R:CARBON FIXED CHIP	560 1/16W J TAPE	R010	1
AT370AHBAE	BRFC165614Z	R:CARBON FIXED CHIP	560 1/16W J TAPE	R014	1
AT370AHBAE	BRFC165614Z	R:CARBON FIXED CHIP	560 1/16W J TAPE	R025	1
AT370AHBAE	BRFC165614Z	R:CARBON FIXED CHIP	560 1/16W J TAPE	R041	1
AT370AHBAE	BRFC165614Z	R:CARBON FIXED CHIP	560 1/16W J TAPE	R047	1
AT370AHBAE	BRFC165614Z	R:CARBON FIXED CHIP	560 1/16W J TAPE	R202	1
AT370AHBAE	BRFC165624Z	R:CARBON FIXED CHIP	5.6K 1/16W J TAPE	R042	1
AT370AHBAE	BRFC165624Z	R:CARBON FIXED CHIP	5.6K 1/16W J TAPE	R044	1
AT370AHBAE	BRFC165624Z	R:CARBON FIXED CHIP	5.6K 1/16W J TAPE	R072	1
AT370AHBAE	BRFC165624Z	R:CARBON FIXED CHIP	5.6K 1/16W J TAPE	R224	1
AT370AHBAE	BRFC165624Z	R:CARBON FIXED CHIP	5.6K 1/16W J TAPE	R237	1
AT370AHBAE	BRFC165624Z	R:CARBON FIXED CHIP	5.6K 1/16W J TAPE	R243	1
AT370AHBAE	BRFC165624Z	R:CARBON FIXED CHIP	5.6K 1/16W J TAPE	R254	1
AT370AHBAE	BRFC165624Z	R:CARBON FIXED CHIP	5.6K 1/16W J TAPE	R377	1
AT370AHBAE	BRFC165634Z	R:CARBON FIXED CHIP	56K 1/16W J TAPE	R037	1
AT370AHBAE	BRFC165634Z	R:CARBON FIXED CHIP	56K 1/16W J TAPE	R083	1
AT370AHBAE	BRFC165644Z	R:CARBON FIXED CHIP	560K 1/16W J TAPE	R064	1
AT370AHBAE	BRFC166814Z	R:CARBON FIXED CHIP	680 1/16W J TAPE	R006	1
AT370AHBAE	BRFC166814Z	R:CARBON FIXED CHIP	680 1/16W J TAPE	R321	1
AT370AHBAE	BRFC166814Z	R:CARBON FIXED CHIP	680 1/16W J TAPE	R322	1
AT370AHBAE	BRFC166814Z	R:CARBON FIXED CHIP	680 1/16W J TAPE	R368	1
AT370AHBAE	BRFC166814Z	R:CARBON FIXED CHIP	680 1/16W J TAPE	R372	1
AT370AHBAE	BRFC166824Z	R:CARBON FIXED CHIP	6.8K 1/16W J TAPE	R004	1
AT370AHBAE	BRFC166824Z	R:CARBON FIXED CHIP	6.8K 1/16W J TAPE	R068	1
AT370AHBAE	BRFC166824Z	R:CARBON FIXED CHIP	6.8K 1/16W J TAPE	R070	1
AT370AHBAE	BRFC166834Z	R:CARBON FIXED CHIP	68K 1/16W J TAPE	R030	1
AT370AHBAE	BRFC168214Z	R:CARBON FIXED CHIP	820 1/16W J TAPE	R328	1
AT370AHBAE	BRFC168224Z	R:CARBON FIXED CHIP	8.2K 1/16W J TAPE	R008	1
AT370AHBAE	BRFC168224Z	R:CARBON FIXED CHIP	8.2K 1/16W J TAPE	R055	1
AT370AHBAE	BRFC168224Z	R:CARBON FIXED CHIP	8.2K 1/16W J TAPE	R216	1
AT370AHBAE	BRFC168234Z	R:CARBON FIXED CHIP	82K 1/16W J TAPE	R082	1
AT370AHBAE	BRFC188204Z	R:CARBON FIXED CHIP	82 1/8W J TAPE	R375	1
AT370AHBAE	BRFT141034Z	R:CARBON AXIAL LEAD (52)	10K 1/4W J TAPE	R378	1
AT370AHBAE	BRFT141034Z	R:CARBON AXIAL LEAD (52)	10K 1/4W J TAPE	R398	1
AT370AHBAE	BRFT141044Z	R:CARBON AXIAL LEAD (52)	100K 1/4W J TAPE	R060	1
AT370AHBAE	BRFT143334Z	R:CARBON AXIAL LEAD (52)	33K 1/4W J TAPE	R054	1
AT370AHBAE	BRPA611034Z	R:CARBON AXIAL LEAD (26)	10K 1/6W J TAPE	R335	1
AT370AHBAE	BRPA611034Z	R:CARBON AXIAL LEAD (26)	10K 1/6W J TAPE	R338	1
AT370AHBAE	BRPA611034Z	R:CARBON AXIAL LEAD (26)	10K 1/6W J TAPE	R340	1
AT370AHBAE	BRPA615614Z	R:CARBON AXIAL LEAD (26)	560 1/6W J TAPE	R232	1
AT370AHBAE	BRSJ001014Z	R:METAL OXIDE	100 1WS J	R220	1
AT370AHBAE	BRSJ005604Z	RESISTOR:METAL OXIDE	56 1WS J	R395	1
AT370AHBAE	BRSJ008204Z	R:METAL OXIDE	82 1WS J	R218	1
AT370AHBAE	BRSJ008204Z	R:METAL OXIDE	82 1WS J	R219	1
AT370AHBAE	BRSJ034794Z	RESISTOR:METAL OXIDE	4.7 3WS J	R086	1
AT370AHBAE	BRTY0569102	R:SEMI-FIXED	RT-569 PVZ3A102A01R00	RT204	1
AT370AHBAE	BRTY0569103	R:SEMI-FIXED	RT-569 PVZ3A103A01R00	RT201	1
AT370AHBAE	BRTY0569222	R:SEMI-FIXED	RT-569 PVZ3A222A01R00	RT001	1
AT370AHBAE	BRTY0569222	R:SEMI-FIXED	RT-569 PVZ3A222A01R00	RT002	1
AT370AHBAE	BRTY0569222	R:SEMI-FIXED	RT-569 PVZ3A222A01R00	RT202	1
AT370AHBAE	BRTY0569222	R:SEMI-FIXED	RT-569 PVZ3A222A01R00	RT203	1
AT370AHBAE	BRTY0569222	R:SEMI-FIXED	RT-569 PVZ3A222A01R00	RT205	1
AT370AHBAE	BRTY0569472	R:SEMI-FIXED	RT-569 PVZ3A472A01R00	RT206	1
AT370AHBAE	BTFY0157001	TRANSFORMER:AF CHOKE	TF-157	T301	1
AT370AHBAE	BTFY0215001	TRANS	TF-215	T302	1

MODEL	HARRY II classic	TOTAL	678		
ASSY CODE	PARTS CODE	DESCRIPTION	SPEC	REF NO	QTY
AT370AHBAE	BTPY0122001	TEST PIN	TP-122 1820-01-PP1	TP001	1
AT370AHBAM	HHSK352447Z	HEAT SINK (COMP)	C2680(BSP)		1
AT370AHBAM	HHSK452777Z	HEAT SINK	C2680(BSP)		0
AT370AHBAM	HHSK452778Z	HEAT SINK	C2680(BSP)		0
AT370AHBAM	HSDC452454Z	SHIELD CASE	SPTE		1
AT370AHBAW	CUAH014041Z	WIRE	UL1007 #24 10-140- 3 GR Y	W001	1
AT370AHBAW	CUAJ014041Z	WIRE	UL 1007 #24 10-140- 3 WHT	W002	1
AT370AHBAW	CUPJ003022Z	WIRE W-004	UL 1571 #26 5- 30- 5 WHT	W003	1
AT370AHBBE	BCML811025Z	C:CERAMIC M/L (1608) TAPE	0.001UF 50V K B	C555	1
AT370AHBBE	BCML811025Z	C:CERAMIC M/L (1608) TAPE	0.001UF 50V K B	C560	1
AT370AHBBE	BCML811035Z	C:CERAMIC M/L (1608) TAPE	0.01UF 50V K B	C551	1
AT370AHBBE	BCML811035Z	C:CERAMIC M/L (1608) TAPE	0.01UF 50V K B	C552	1
AT370AHBBE	BCML811035Z	C:CERAMIC M/L (1608) TAPE	0.01UF 50V K B	C553	1
AT370AHBBE	BCML811035Z	C:CERAMIC M/L (1608) TAPE	0.01UF 50V K B	C554	1
AT370AHBBE	BCML811035Z	C:CERAMIC M/L (1608) TAPE	0.01UF 50V K B	C556	1
AT370AHBBE	BCML811035Z	C:CERAMIC M/L (1608) TAPE	0.01UF 50V K B	C557	1
AT370AHBBE	BCML811035Z	C:CERAMIC M/L (1608) TAPE	0.01UF 50V K B	C558	1
AT370AHBBE	BCML811035Z	C:CERAMIC M/L (1608) TAPE	0.01UF 50V K B	C559	1
AT370AHBBE	BDAG1261001	DIODE:LED	DA-1261 BD2-40TYG-A12U	D551	1
AT370AHBBE	BDAY1082015	DIODE:ZENER	UDZS7.5B TE-17	D552	1
AT370AHBBE	BDAY1082015	DIODE:ZENER	UDZS7.5B TE-17	D553	1
AT370AHBBE	BDAY1082015	DIODE:ZENER	UDZS7.5B TE-17	D554	1
AT370AHBBE	BLDY0087001	COIL	LD-087 BF04-3*5*1	L551	1
AT370AHBBE	BLDY0087001	COIL	LD-087 BF04-3*5*1	L554	1
AT370AHBBE	BLDY0087001	COIL	LD-087 BF04-3*5*1	L555	1
AT370AHBBE	BLZY0041100	INDUCTOR:MOLDED	LZ-041 10UH K	L552	1
AT370AHBBE	BLZY0041100	INDUCTOR:MOLDED	LZ-041 10UH K	L553	1
AT370AHBBE	BPAG0435AA2	PCB:FRONT	PA-435AA 2/4	B551	1
AT370AHBBE	BRFC161024Z	R:CARBON FIXED CHIP	1K 1/16W J TAPE	R551	1
AT370AHBBE	BRFC161024Z	R:CARBON FIXED CHIP	1K 1/16W J TAPE	R552	1
AT370AHBBE	BRFC161024Z	R:CARBON FIXED CHIP	1K 1/16W J TAPE	R553	1
AT370AHBBE	BRFC161024Z	R:CARBON FIXED CHIP	1K 1/16W J TAPE	R555	1
AT370AHBBE	BRFC164724Z	R:CARBON FIXED CHIP	4.7K 1/16W J TAPE	R556	1
AT370AHBBE	BRFC166824Z	R:CARBON FIXED CHIP	6.8K 1/16W J TAPE	R554	1
AT370AHBBE	BSWY0557001	SWITCH:SLIDE	SW-557 SSFYP22-14.5B	S551	1
AT370AHBBE	BSWY0557001	SWITCH:SLIDE	SW-557 SSFYP22-14.5B	S552	1
AT370AHBBE	BSWY0557001	SWITCH:SLIDE	SW-557 SSFYP22-14.5B	S553	1
AT370AHBBM	GHDL418694A	HOLDER:LED	ABS BLACK		1
AT370AHBCE	BCML811035Z	C:CERAMIC M/L (1608) TAPE	0.01UF 50V K B	C701	1
AT370AHBCE	BCML811035Z	C:CERAMIC M/L (1608) TAPE	0.01UF 50V K B	C702	1
AT370AHBCE	BPAG0435AA3	PCB:SW	PA-435AA 3/4	B701	1
AT370AHBCE	BRFC161024Z	R:CARBON FIXED CHIP	1K 1/16W J TAPE	R701	1
AT370AHBCE	BRFC161024Z	R:CARBON FIXED CHIP	1K 1/16W J TAPE	R702	1
AT370AHBCE	BSRG0458001	SWITCH:ROTARY	SR-458 SR10030F-30F-F7-008	S701	1
AT370AHBDE	BPAG0435AA4	PCB:VOLUME	PA-435AA 4/4	B801	1
AT370AHBDE	BRVY0903001	R:VARIABLE(TP96N00N 25F A503)	RV-903 RY-6467 50KA/S	VR801	1
AT370AHBDW	CZDZ072065Z	WIRES ASSEMBLED	W-072065	WA801	1
AT370AHBYE	BDBB1135117	TRANSISTOR	DB-147 2SB1135R	Q503	1
AT370AHBYE	BDBC2078105	TRANSISTOR	DB-791 2SC2078E	Q501	1
AT370AHBYE	BDEY0919001	INTEGRATED CIRCUIT	TDA2003V	IC501	1
AT370AHBYE	BDEY0924001	INTEGRATED CIRCUIT	L7808CV	IC502	1
AT370AHBYE	BJKY0425002	JACK:W/O LUG	JK-425 M-RM-L 102	J501	1
AT370AHBYE	BJKY0649001	JACK	JK-649 6S-L113-02A	J502	1
AT370AHBYE	BRVY0672001	RESISTOR:VARIABLE	RV-672 5KB	VR501	1
AT370AHBYE	BRVY0672001	RESISTOR:VARIABLE	RV-672 5KB	VR502	1
AT370AHBYE	BSPY0238001	SPEAKER	SP-238 77R90T0403	SP501	1
AT370AHBYE	BWZY1105001	CORD:DC CORD	WZ-1105 1500 W/P	WA501	1
AT370AHBYE	BYDY0019003	BUSHING	YD-019 B312D-11-A	YI503	1
AT370AHBYE	BYYY0027001	INSULATION SHEET	YY-027	Y501	1
AT370AHBYE	BYYY0027001	INSULATION SHEET	YY-027	Y502	1
AT370AHBYM	GCAS2B9973Z	PANEL:FRONT	ABS		1

MODEL	HARRY II classic	TOTAL	678		
ASSY CODE	PARTS CODE	DESCRIPTION	SPEC	REF NO	QTY
AT370AHBYM	GNBC418695Z	KNOB:CHANNEL	ABS,BLACK		1
AT370AHBYM	GNBY418593A	KNOB	ABS,BLACK		3
AT370AHBYM	HCAS3B9766Z	COVER:BOTTOM	VINY TOP		1
AT370AHBYM	HCMT318698C	COVER:TOP	VINYTOP E,0.75T,BLACK		1
AT370AHBYM	HCSY2B9763Z	CHASSIS	SECC		1
AT370AHBYM	HHSK4B9767Z	HEAT SINK	A1070P(AL)		1
AT370AHBYM	HSDC352448Z	SHIELD PLATE	C5210(PBSP)		1
AT370AHBYM	KDPZ3C0840Z	PLATE:DISPLAY	PC		1
AT370AHBYM	PLBS459497Z	LABEL:ID	**		1
AT370AHBYM	PLBS459498Z	LABEL:ID	PAPER		2
AT370AHBYM	PLBZ474165Z	LABEL:TA	**		1
AT370AHBYM	PLBZ493436Z	CB STICKER (S)	**		1
AT370AHBYM	PLBZ493437A	WIRING STICKER	**		1
AT370AHBYM	PLBZ4B1100Z	LABEL:INDICATION	PAPER		1
AT370AHBYM	RCUN4B9842Z	CUSHION	NEOPRENE		1
AT370AHBYM	RCUN4C0269Z	CUSHION	NEOPRENE		1
AT370AHBYM	RETC490493A	SPACER	WOOL TACK,0.5T,BLACK		2
AT370AHBYM	RUTC418435Z	WOOL-COATED PAPER:WOOL TACK	WOOL PAPER,100*5*0.3T		4
AT370AHBYM	SSCW133005N	SCREW:FLAT HD +	M3X5 NI	1	2
AT370AHBYM	SSCW193008D	SCREW:BIND HD +	M3X8 BZMC	1	4
AT370AHBYM	SSCW193008N	SCREW:BIND HD +	M3X8 NI	1	1
AT370AHBYM	SSCW193010N	SCREW:BIND HD +	M3X10 NI	1	5
AT370AHBYM	SSCW343006D	SCREW:TAPTIGHT BIND HD +	M3X6 BZMC	1	8
AT370AHBYM	SSCW343006N	SCREW:TAPTIGHT BIND HD +	M3X6 NI	1	4
AT370AHBYM	SSCW430030N	HEX NUT	M3.0 NI	1	5
AT370AHBYM	SSCW480030Z	NUT:FLANGE	M3 ZMC	1	4
AT370AHBYM	TSTD0200003	SPRING PLATE:KNOB	D6.02XL9.53		4
AT370AHXYE	BMKY0540001	MICROPHONE	MK-540 EMC502-027	MC951	1
AT370AHXYM	GMSC480407A	SCREW:MOUNTING	ABS,BLACK		2
AT370AHXYM	HBCT418696A	MOUNTING BRACKET	SPCC 1.2T MFZN3		1
AT370AHXYM	HMHG402919Z	HANGER:MICROPHONE	SPCC,1.0T,NI		1
AT370AHXYM	SSCW293508N	SCREW:TAPPING ROUND HD +	D3.5X8 NI	1	2
AT370AHXYM	SSCW295010N	SCREW:TAPPING ROUND HD +	D5X10 NI	1	2
AT370AHXYM	SSCW530035N	WASHER:LOCK	D3.5 NI	1	2
AT370AHXYM	SSCW540050N	WASHER:STAR	D5 NI	1	2
AT370AHXYM	UTZZ01370AZ	OWNERS MANUAL	**		1
AT370AHXYM	VNYL2404080	VINYL BAG	400X400X800X0.07T		0,083
AT370AHXYM	VNYL3101500	VINYL BAG	100X150X0.1T		1
AT370AHXYM	VNYL3102500	VINYL BAG	100X250X0.1T		1
AT370AHXYM	VNYL3203000	VINYL BAG	200X300X0.1T		2
AT370AHXYM	WBXZ3C0058Z	DISPLAY BOX	**		1
AT370AHXYM	WCTZ3C0282A	SHIPPING CARTON BOX	**		0,083
AT370AHXYM	WSLV3C0280Z	SLEEVE	**		1
AT370AHXYM	WSLV4C0278Z	SLEEVE	**		1
AT370AHXYM	WSLV4C0279Z	SLEEVE	**		1

COMPONENTS LIST

HARRY II ASC

MODEL	HARRY II ASC	TOTAL	711		
ASSY CODE	PARTS CODE	DESCRIPTION	SPEC	REF NO	QTY
AT370ZHBAE	BCAZ112216Z	C:ELECTROLYTIC	220UF 10V M C-156	C245	1
AT370ZHBAE	BCAZ112216Z	C:ELECTROLYTIC	220UF 10V M C-156	C317	1
AT370ZHBAE	BCAZ112216Z	C:ELECTROLYTIC	220UF 10V M C-156	C320	1
AT370ZHBAE	BCAZ112216Z	C:ELECTROLYTIC	220UF 10V M C-156	C350	1
AT370ZHBAE	BCAZ114716Z	C:ELECTROLYTIC	470UF 10V M C-156	C312	1
AT370ZHBAE	BCAZ311026Z	C:ELECTROLYTIC	1000UF 16V M C-156	C235	1
AT370ZHBAE	BCAZ511026Z	C:ELECTROLYTIC	1000UF 25V M C-156	C315	1
AT370ZHBAE	BCAZ514706Z	C:ELECTROLYTIC	47UF 25V M C-156	C030	1
AT370ZHBAE	BCAZ514706Z	C:ELECTROLYTIC	47UF 25V M C-156	C031	1
AT370ZHBAE	BCAZ514706Z	C:ELECTROLYTIC	47UF 25V M C-156	C044	1
AT370ZHBAE	BCAZ514706Z	C:ELECTROLYTIC	47UF 25V M C-156	C047	1
AT370ZHBAE	BCAZ514706Z	C:ELECTROLYTIC	47UF 25V M C-156	C065	1
AT370ZHBAE	BCAZ514706Z	C:ELECTROLYTIC	47UF 25V M C-156	C253	1
AT370ZHBAE	BCAZ514706Z	C:ELECTROLYTIC	47UF 25V M C-156	C310	1
AT370ZHBAE	BCAZ514716Z	C:ELECTROLYTIC	470UF 25V M C-156	C043	1
AT370ZHBAE	BCAZ811096Z	C:ELECTROLYTIC	1UF 50V M C-156	C011	1
AT370ZHBAE	BCAZ812206Z	C:ELECTROLYTIC	22UF 50V M C-156	C366	1
AT370ZHBAE	BCAZ814786Z	C:ELECTROLYTIC	0.47UF 50V M C-156	C021	1
AT370ZHBAE	BCAZ814796Z	C:ELECTROLYTIC	4.7UF 50V M C-156	C004	1
AT370ZHBAE	BCMF111050Z	C:CERAMIC M/L (1608) TAPE	1UF 10V Z F	C036	1
AT370ZHBAE	BCMF111050Z	C:CERAMIC M/L (1608) TAPE	1UF 10V Z F	C237	1
AT370ZHBAE	BCMF111050Z	C:CERAMIC M/L (1608) TAPE	1UF 10V Z F	C240	1
AT370ZHBAE	BCMF111050Z	C:CERAMIC M/L (1608) TAPE	1UF 10V Z F	C408	1
AT370ZHBAE	BCMF111050Z	C:CERAMIC M/L (1608) TAPE	1UF 10V Z F	C411	1
AT370ZHBAE	BCML311045Z	C:CERAMIC M/L (1608) TAPE	0.1UF 16V K B	C023	1
AT370ZHBAE	BCML311045Z	C:CERAMIC M/L (1608) TAPE	0.1UF 16V K B	C024	1
AT370ZHBAE	BCML311045Z	C:CERAMIC M/L (1608) TAPE	0.1UF 16V K B	C026	1
AT370ZHBAE	BCML311045Z	C:CERAMIC M/L (1608) TAPE	0.1UF 16V K B	C027	1
AT370ZHBAE	BCML311045Z	C:CERAMIC M/L (1608) TAPE	0.1UF 16V K B	C033	1
AT370ZHBAE	BCML311045Z	C:CERAMIC M/L (1608) TAPE	0.1UF 16V K B	C042	1
AT370ZHBAE	BCML311045Z	C:CERAMIC M/L (1608) TAPE	0.1UF 16V K B	C045	1
AT370ZHBAE	BCML311045Z	C:CERAMIC M/L (1608) TAPE	0.1UF 16V K B	C046	1
AT370ZHBAE	BCML311045Z	C:CERAMIC M/L (1608) TAPE	0.1UF 16V K B	C053	1
AT370ZHBAE	BCML311045Z	C:CERAMIC M/L (1608) TAPE	0.1UF 16V K B	C055	1
AT370ZHBAE	BCML311045Z	C:CERAMIC M/L (1608) TAPE	0.1UF 16V K B	C212	1
AT370ZHBAE	BCML311045Z	C:CERAMIC M/L (1608) TAPE	0.1UF 16V K B	C228	1
AT370ZHBAE	BCML311045Z	C:CERAMIC M/L (1608) TAPE	0.1UF 16V K B	C230	1
AT370ZHBAE	BCML311045Z	C:CERAMIC M/L (1608) TAPE	0.1UF 16V K B	C238	1
AT370ZHBAE	BCML311045Z	C:CERAMIC M/L (1608) TAPE	0.1UF 16V K B	C243	1
AT370ZHBAE	BCML311045Z	C:CERAMIC M/L (1608) TAPE	0.1UF 16V K B	C247	1
AT370ZHBAE	BCML311045Z	C:CERAMIC M/L (1608) TAPE	0.1UF 16V K B	C254	1
AT370ZHBAE	BCML311045Z	C:CERAMIC M/L (1608) TAPE	0.1UF 16V K B	C304	1
AT370ZHBAE	BCML311045Z	C:CERAMIC M/L (1608) TAPE	0.1UF 16V K B	C306	1
AT370ZHBAE	BCML311045Z	C:CERAMIC M/L (1608) TAPE	0.1UF 16V K B	C308	1
AT370ZHBAE	BCML311045Z	C:CERAMIC M/L (1608) TAPE	0.1UF 16V K B	C311	1
AT370ZHBAE	BCML311045Z	C:CERAMIC M/L (1608) TAPE	0.1UF 16V K B	C319	1
AT370ZHBAE	BCML311045Z	C:CERAMIC M/L (1608) TAPE	0.1UF 16V K B	C321	1
AT370ZHBAE	BCML311045Z	C:CERAMIC M/L (1608) TAPE	0.1UF 16V K B	C324	1
AT370ZHBAE	BCML311045Z	C:CERAMIC M/L (1608) TAPE	0.1UF 16V K B	C325	1
AT370ZHBAE	BCML311045Z	C:CERAMIC M/L (1608) TAPE	0.1UF 16V K B	C372	1
AT370ZHBAE	BCML311045Z	C:CERAMIC M/L (1608) TAPE	0.1UF 16V K B	C387	1
AT370ZHBAE	BCML311045Z	C:CERAMIC M/L (1608) TAPE	0.1UF 16V K B	C388	1
AT370ZHBAE	BCML311045Z	C:CERAMIC M/L (1608) TAPE	0.1UF 16V K B	C412	1
AT370ZHBAE	BCML311055Z	C:CERAMIC M/L (1608) TAPE	1UF 16V K B	C403	1
AT370ZHBAE	BCML315635Z	C:CERAMIC M/L (1608) TAPE	0.056UF 16V K B	C231	1
AT370ZHBAE	BCML811025Z	C:CERAMIC M/L (1608) TAPE	0.001UF 50V K B	C003	1
AT370ZHBAE	BCML811025Z	C:CERAMIC M/L (1608) TAPE	0.001UF 50V K B	C005	1
AT370ZHBAE	BCML811025Z	C:CERAMIC M/L (1608) TAPE	0.001UF 50V K B	C022	1
AT370ZHBAE	BCML811025Z	C:CERAMIC M/L (1608) TAPE	0.001UF 50V K B	C028	1
AT370ZHBAE	BCML811025Z	C:CERAMIC M/L (1608) TAPE	0.001UF 50V K B	C032	1
AT370ZHBAE	BCML811025Z	C:CERAMIC M/L (1608) TAPE	0.001UF 50V K B	C034	1
AT370ZHBAE	BCML811025Z	C:CERAMIC M/L (1608) TAPE	0.001UF 50V K B	C048	1
AT370ZHBAE	BCML811025Z	C:CERAMIC M/L (1608) TAPE	0.001UF 50V K B	C049	1

MODEL	HARRY II ASC	TOTAL	711		
ASSY CODE	PARTS CODE	DESCRIPTION	SPEC	REF NO	QTY
AT370ZHBAE	BCML814735Z	C:CERAMIC M/L (1608) TAPE	0.047UF 50V K B	C016	1
AT370ZHBAE	BCML814735Z	C:CERAMIC M/L (1608) TAPE	0.047UF 50V K B	C018	1
AT370ZHBAE	BCML814735Z	C:CERAMIC M/L (1608) TAPE	0.047UF 50V K B	C019	1
AT370ZHBAE	BCML814735Z	C:CERAMIC M/L (1608) TAPE	0.047UF 50V K B	C020	1
AT370ZHBAE	BCML814735Z	C:CERAMIC M/L (1608) TAPE	0.047UF 50V K B	C035	1
AT370ZHBAE	BCML814735Z	C:CERAMIC M/L (1608) TAPE	0.047UF 50V K B	C037	1
AT370ZHBAE	BCML814735Z	C:CERAMIC M/L (1608) TAPE	0.047UF 50V K B	C038	1
AT370ZHBAE	BCML814735Z	C:CERAMIC M/L (1608) TAPE	0.047UF 50V K B	C218	1
AT370ZHBAE	BCML814735Z	C:CERAMIC M/L (1608) TAPE	0.047UF 50V K B	C246	1
AT370ZHBAE	BCML814735Z	C:CERAMIC M/L (1608) TAPE	0.047UF 50V K B	C250	1
AT370ZHBAE	BCML814735Z	C:CERAMIC M/L (1608) TAPE	0.047UF 50V K B	C313	1
AT370ZHBAE	BCML814735Z	C:CERAMIC M/L (1608) TAPE	0.047UF 50V K B	C316	1
AT370ZHBAE	BCML814735Z	C:CERAMIC M/L (1608) TAPE	0.047UF 50V K B	C330	1
AT370ZHBAE	BCML814735Z	C:CERAMIC M/L (1608) TAPE	0.047UF 50V K B	C409	1
AT370ZHBAE	BCMM811002Z	C:CERAMIC M/L (1608) TAPE	10PF 50V D CH	C367	1
AT370ZHBAE	BCMM811002Z	C:CERAMIC M/L (1608) TAPE	10PF 50V D CH	C378	1
AT370ZHBAE	BCMM811014Z	C:CERAMIC M/L (1608) TAPE	100PF 50V J CH	C006	1
AT370ZHBAE	BCMM811014Z	C:CERAMIC M/L (1608) TAPE	100PF 50V J CH	C062	1
AT370ZHBAE	BCMM811214Z	C:CERAMIC M/L (1608) TAPE	120PF 50V J CH	C201	1
AT370ZHBAE	BCMM811214Z	C:CERAMIC M/L (1608) TAPE	120PF 50V J CH	C219	1
AT370ZHBAE	BCMM811504Z	C:CERAMIC M/L (1608) TAPE	15PF 50V J CH	C213	1
AT370ZHBAE	BCMM811514Z	C:CERAMIC M/L (1608) TAPE	150PF 50V J CH	C368	1
AT370ZHBAE	BCMM811514Z	C:CERAMIC M/L (1608) TAPE	150PF 50V J CH	C369	1
AT370ZHBAE	BCMM811804Z	C:CERAMIC M/L (1608) TAPE	18PF 50V J CH	C203	1
AT370ZHBAE	BCMM811804Z	C:CERAMIC M/L (1608) TAPE	18PF 50V J CH	C381	1
AT370ZHBAE	BCMM811804Z	C:CERAMIC M/L (1608) TAPE	18PF 50V J CH	C382	1
AT370ZHBAE	BCMM811814Z	C:CERAMIC M/L (1608) TAPE	180PF 50V J CH	C204	1
AT370ZHBAE	BCMM811814Z	C:CERAMIC M/L (1608) TAPE	180PF 50V J CH	C206	1
AT370ZHBAE	BCMM812098Z	C:CERAMIC M/L (1608) TAPE	2PF 50V B CH	C363	1
AT370ZHBAE	BCMM812204Z	C:CERAMIC M/L (1608) TAPE	22PF 50V J CH	C001	1
AT370ZHBAE	BCMM812204Z	C:CERAMIC M/L (1608) TAPE	22PF 50V J CH	C301	1
AT370ZHBAE	BCMM812204Z	C:CERAMIC M/L (1608) TAPE	22PF 50V J CH	C302	1
AT370ZHBAE	BCMM812204Z	C:CERAMIC M/L (1608) TAPE	22PF 50V J CH	C380	1
AT370ZHBAE	BCMM812214Z	C:CERAMIC M/L (1608) TAPE	220PF 50V J CH	C202	1
AT370ZHBAE	BCMM812214Z	C:CERAMIC M/L (1608) TAPE	220PF 50V J CH	C208	1
AT370ZHBAE	BCMM812214Z	C:CERAMIC M/L (1608) TAPE	220PF 50V J CH	C223	1
AT370ZHBAE	BCMM812704Z	C:CERAMIC M/L (1608) TAPE	27PF 50V J CH	C063	1
AT370ZHBAE	BCMM812704Z	C:CERAMIC M/L (1608) TAPE	27PF 50V J CH	C224	1
AT370ZHBAE	BCMM813098Z	C:CERAMIC M/L (1608) TAPE	3PF 50V B CH	C007	1
AT370ZHBAE	BCMM813314Z	C:CERAMIC M/L (1608) TAPE	330PF 50V J CH	C207	1
AT370ZHBAE	BCMM813314Z	C:CERAMIC M/L (1608) TAPE	330PF 50V J CH	C214	1
AT370ZHBAE	BCMM813904Z	C:CERAMIC M/L (1608) TAPE	39PF 50V J CH	C215	1
AT370ZHBAE	BCMM813904Z	C:CERAMIC M/L (1608) TAPE	39PF 50V J CH	C322	1
AT370ZHBAE	BCMM814704Z	C:CERAMIC M/L (1608) TAPE	47PF 50V J CH	C041	1
AT370ZHBAE	BCMM815091Z	C:CERAMIC M/L (1608) TAPE	5PF 50V C CH	C226	1
AT370ZHBAE	BCMM815604Z	C:CERAMIC M/L (1608) TAPE	56PF 50V J CH	C361	1
AT370ZHBAE	BCMM815614Z	C:CERAMIC M/L (1608) TAPE	560PF 50V J CH	C015	1
AT370ZHBAE	BCMM816804Z	C:CERAMIC M/L (1608) TAPE	68PF 50V J CH	C259	1
AT370ZHBAE	BCMM816814Z	C:CERAMIC M/L (1608) TAPE	680PF 50V J CH	C232	1
AT370ZHBAE	BCMM818204Z	C:CERAMIC M/L (1608) TAPE	82PF 50V J CH	C210	1
AT370ZHBAE	BCMS812091Z	C:CERAMIC M/L (1608) TAPE	2PF 50V C CK	C209	1
AT370ZHBAE	BESH464796Z	C:TANTALUM CHIP TAPE	4.7UF 20V M A C-122	C040	1
AT370ZHBAE	BESH514786Z	C:TANTALUM CHIP TAPE	0.47UF 25V M C-122 TAPE	C376	1
AT370ZHBAE	BESH661086Z	CAPACITOR:TANTALUM CHIP	0.1UF 35V M C-122 TAPE	C375	1
AT370ZHBAE	BCTY0090500	C:TRIMMER	CT-090 ECR-LA050M52 50PF	CT301	1
AT370ZHBAE	BDAY0274001	DIODE	1SS226 TE85L	D401	1
AT370ZHBAE	BDAY0808001	DIODE:SWITCHING	1SS356 TW11	D001	1
AT370ZHBAE	BDAY0808001	DIODE:SWITCHING	1SS356 TW11	D002	1
AT370ZHBAE	BDAY0811001	DIODE	SB340	D304	1
AT370ZHBAE	BDAY0940001	DIODE:VARICAP	HVU307 TRU	D207	1
AT370ZHBAE	BDAY0940001	DIODE:VARICAP	HVU307 TRU	D362	1
AT370ZHBAE	BDAY0940001	DIODE:VARICAP	HVU307 TRU	D363	1
AT370ZHBAE	BDAY0993001	DIODE	KDS160E-RTK	D003	1
AT370ZHBAE	BDAY0993001	DIODE	KDS160E-RTK	D004	1

MODEL	HARRY II ASC	TOTAL	711		
ASSY CODE	PARTS CODE	DESCRIPTION	SPEC	REF NO	QTY
AT370ZHBAE	BDAY0993001	DIODE	KDS160E-RTK	D005	1
AT370ZHBAE	BDAY0993001	DIODE	KDS160E-RTK	D006	1
AT370ZHBAE	BDAY0993001	DIODE	KDS160E-RTK	D007	1
AT370ZHBAE	BDAY0993001	DIODE	KDS160E-RTK	D008	1
AT370ZHBAE	BDAY0993001	DIODE	KDS160E-RTK	D009	1
AT370ZHBAE	BDAY0993001	DIODE	KDS160E-RTK	D011	1
AT370ZHBAE	BDAY0993001	DIODE	KDS160E-RTK	D201	1
AT370ZHBAE	BDAY0993001	DIODE	KDS160E-RTK	D202	1
AT370ZHBAE	BDAY0993001	DIODE	KDS160E-RTK	D203	1
AT370ZHBAE	BDAY0993001	DIODE	KDS160E-RTK	D205	1
AT370ZHBAE	BDAY0993001	DIODE	KDS160E-RTK	D302	1
AT370ZHBAE	BDAY0993001	DIODE	KDS160E-RTK	D307	1
AT370ZHBAE	BDAY0993001	DIODE	KDS160E-RTK	D308	1
AT370ZHBAE	BDAY0993001	DIODE	KDS160E-RTK	D309	1
AT370ZHBAE	BDAY0993001	DIODE	KDS160E-RTK	D311	1
AT370ZHBAE	BDAY0993001	DIODE	KDS160E-RTK	D402	1
AT370ZHBAE	BDAY1082004	DIODE:ZENER	UDZS5.1B TE-17	D306	1
AT370ZHBAE	BDAY1082004	DIODE:ZENER	UDZS5.1B TE-17	D361	1
AT370ZHBAE	BDAY1082013	DIODE:ZENER	UDZS5.6B TE-17	D010	1
AT370ZHBAE	BDAY1082015	DIODE:ZENER	UDZS7.5B TE-17	D301	1
AT370ZHBAE	BDAY1082016	DIODE:ZENER	UDZS3.0B TE-17	D206	1
AT370ZHBAE	BDAY1185001	DIODE	GD 1N4003-A2	D204	1
AT370ZHBAE	BDBA1235106	TRANSISTOR	DB-092 2SA1235A-T12-1F	Q212	1
AT370ZHBAE	BDBA1235106	TRANSISTOR	DB-092 2SA1235A-T12-1F	Q215	1
AT370ZHBAE	BDBA1235106	TRANSISTOR	DB-092 2SA1235A-T12-1F	Q306	1
AT370ZHBAE	BDBA1235106	TRANSISTOR	DB-092 2SA1235A-T12-1F	Q307	1
AT370ZHBAE	BDBA1235106	TRANSISTOR	DB-092 2SA1235A-T12-1F	Q311	1
AT370ZHBAE	BDBA1235106	TRANSISTOR	DB-092 2SA1235A-T12-1F	Q313	1
AT370ZHBAE	BDBC0941523	TRANSISTOR	DB-301 2SC941TM-O	Q202	1
AT370ZHBAE	BDBC2314106	TRANSISTOR	DB-792 2SC2314F	Q201	1
AT370ZHBAE	BDBC2714124	TRANSISTOR	DB-718 2SC2714-Y TE85L	Q001	1
AT370ZHBAE	BDBC2714124	TRANSISTOR	DB-718 2SC2714-Y TE85L	Q004	1
AT370ZHBAE	BDBC2714124	TRANSISTOR	DB-718 2SC2714-Y TE85L	Q005	1
AT370ZHBAE	BDBC2714124	TRANSISTOR	DB-718 2SC2714-Y TE85L	Q013	1
AT370ZHBAE	BDBC2714124	TRANSISTOR	DB-718 2SC2714-Y TE85L	Q203	1
AT370ZHBAE	BDBC2714124	TRANSISTOR	DB-718 2SC2714-Y TE85L	Q302	1
AT370ZHBAE	BDBC2714124	TRANSISTOR	DB-718 2SC2714-Y TE85L	Q303	1
AT370ZHBAE	BDBC3052106	TRANSISTOR	DB-862 2SC3052-T12-1F	Q006	1
AT370ZHBAE	BDBC3052106	TRANSISTOR	DB-862 2SC3052-T12-1F	Q007	1
AT370ZHBAE	BDBC3052106	TRANSISTOR	DB-862 2SC3052-T12-1F	Q008	1
AT370ZHBAE	BDBC3052106	TRANSISTOR	DB-862 2SC3052-T12-1F	Q009	1
AT370ZHBAE	BDBC3052106	TRANSISTOR	DB-862 2SC3052-T12-1F	Q011	1
AT370ZHBAE	BDBC3052106	TRANSISTOR	DB-862 2SC3052-T12-1F	Q012	1
AT370ZHBAE	BDBC3052106	TRANSISTOR	DB-862 2SC3052-T12-1F	Q014	1
AT370ZHBAE	BDBC3052106	TRANSISTOR	DB-862 2SC3052-T12-1F	Q207	1
AT370ZHBAE	BDBC3052106	TRANSISTOR	DB-862 2SC3052-T12-1F	Q208	1
AT370ZHBAE	BDBC3052106	TRANSISTOR	DB-862 2SC3052-T12-1F	Q211	1
AT370ZHBAE	BDBC3052106	TRANSISTOR	DB-862 2SC3052-T12-1F	Q213	1
AT370ZHBAE	BDBC3052106	TRANSISTOR	DB-862 2SC3052-T12-1F	Q216	1
AT370ZHBAE	BDBC3052106	TRANSISTOR	DB-862 2SC3052-T12-1F	Q301	1
AT370ZHBAE	BDBC3052106	TRANSISTOR	DB-862 2SC3052-T12-1F	Q309	1
AT370ZHBAE	BDBC3052106	TRANSISTOR	DB-862 2SC3052-T12-1F	Q312	1
AT370ZHBAE	BDBC3052106	TRANSISTOR	DB-862 2SC3052-T12-1F	Q314	1
AT370ZHBAE	BDBC3052106	TRANSISTOR	DB-862 2SC3052-T12-1F	Q401	1
AT370ZHBAE	BDBC3052106	TRANSISTOR	DB-862 2SC3052-T12-1F	Q403	1
AT370ZHBAE	BDBC3243105	TRANSISTOR	DB-867 2SC3243-T11-E	Q209	1
AT370ZHBAE	BDBC3243105	TRANSISTOR	DB-867 2SC3243-T11-E	Q308	1
AT370ZHBAE	BDBC5065124	TRANSISTOR	DB-848 2SC5065-Y(TE85R)	Q304	1
AT370ZHBAE	BDBD1048661	TRANSISTOR	DB-435 2SD1048-X6 TB	Q010	1
AT370ZHBAE	BDBD1048661	TRANSISTOR	DB-435 2SD1048-X6 TB	Q214	1
AT370ZHBAE	BDBD1048661	TRANSISTOR	DB-435 2SD1048-X6 TB	Q305	1
AT370ZHBAE	BDCB0210301	FIELD EFFECT TRANSISTOR	DC-022 2SK210-BL TE85L	Q002	1
AT370ZHBAE	BDCB0210301	FIELD EFFECT TRANSISTOR	DC-022 2SK210-BL TE85L	Q003	1
AT370ZHBAE	BDDG1515001	INTEGRATED CIRCUIT:UC2971	UPD780021AGB-G26-8EU-A	IC301	1

MODEL	HARRY II ASC	TOTAL	711		
ASSY CODE	PARTS CODE	DESCRIPTION	SPEC	REF NO	QTY
AT370ZHBAE	BDEG4222003	INERGRATED CIRCUIT	TK83361MTL-G	IC001	1
AT370ZHBAE	BDEG4251003	INTEGRATED CIRCUIT	RH5RL50AA-T1-FA	IC304	1
AT370ZHBAE	BDEY2769003	INTEGRATED CIRCUIT	BU2630F-E2	IC306	1
AT370ZHBAE	BDEY3654003	INTEGRATED CIRCUIT	NJM12904M-TE3--#ZZZB	IC002	1
AT370ZHBAE	BDEY3654003	INTEGRATED CIRCUIT	NJM12904M-TE3--#ZZZB	IC201	1
AT370ZHBAE	BDEY3654003	INTEGRATED CIRCUIT	NJM12904M-TE3--#ZZZB	IC202	1
AT370ZHBAE	BDEY3654003	INTEGRATED CIRCUIT	NJM12904M-TE3--#ZZZB	IC401	1
AT370ZHBAE	BDEY3664003	INTEGRATED CIRCUIT	S-24CC02A-J8T1	IC302	1
AT370ZHBAE	BDEY4017003	INTEGRATED CIRCUIT	XC61CC4302PR/XC61AC4302PR	IC303	1
AT370ZHBAE	BFLY0055001	FILTER:CRYSTAL	FL-055 10M07AZ	FT001	1
AT370ZHBAE	BFLY0852001	FILTER:CERAMIC	FL-852 LTS455HTW	FT002	1
AT370ZHBAE	BJKG1249003	JACK	JK-1249 IMSA-9210B-1-03Z058-PT1	J004	1
AT370ZHBAE	BJKY0899001	JACK:EARPHONE	JK-899 JH3501-020D	J003	1
AT370ZHBAE	BLBG1226001	COIL	LB-1226 KY1107R	L360	1
AT370ZHBAE	BLBG1226001	COIL	LB-1226 KY1107R	L361	1
AT370ZHBAE	BLBG1227001	COIL	LB-1227 KS2553N	L003	1
AT370ZHBAE	BLBY1120001	COIL	LB-1120 KS2482AC	L004	1
AT370ZHBAE	BLBY1129001	COIL	LB-1129 7PL4A151N	L006	1
AT370ZHBAE	BLBY1131001	COIL	LB-1131 KS2484F	L001	1
AT370ZHBAE	BLBY1153001	COIL	LB-1153 KS2485NC	L002	1
AT370ZHBAE	BLBY1175001	COIL	LB-1175 7002BE-A0026HM	L009	1
AT370ZHBAE	BLBY1179001	COIL	LB-1179 7MK4A033N	L007	1
AT370ZHBAE	BLCY0255001	COIL	LC-255 MD146-08F42	L205	1
AT370ZHBAE	BLDY0087001	COIL	LD-087 BF04-3*5*1	L010	1
AT370ZHBAE	BLDY0087001	COIL	LD-087 BF04-3*5*1	L011	1
AT370ZHBAE	BLDY0087001	COIL	LD-087 BF04-3*5*1	L207	1
AT370ZHBAE	BLDY0087001	COIL	LD-087 BF04-3*5*1	L209	1
AT370ZHBAE	BLDY0087001	COIL	LD-087 BF04-3*5*1	L211	1
AT370ZHBAE	BLDY0252001	COIL	LD-252 3A1737RH	L206	1
AT370ZHBAE	BLDY0252001	COIL	LD-252 3A1737RH	L301	1
AT370ZHBAE	BLDY0252001	COIL	LD-252 3A1737RH	L302	1
AT370ZHBAE	BLEY0475001	COIL	LE-475 AC1979	L201	1
AT370ZHBAE	BLEY0475001	COIL	LE-475 AC1979	L204	1
AT370ZHBAE	BLEY0486001	COIL	LE-486 AC1973	L202	1
AT370ZHBAE	BLEY0486001	COIL	LE-486 AC1973	L203	1
AT370ZHBAE	BLEY0535001	COIL	LE-535	L208	1
AT370ZHBAE	BLZY0041338	INDUCTOR:MOLDED	LZ-041 0.33UH K	L210	1
AT370ZHBAE	BPAG0435AA1	PCB:MAIN	PA-435AA 1/4	B001	1
AT370ZHBAE	BPGG0185001	PLUG	PG-185 IMSA-9215H-T	PG001	1
AT370ZHBAE	BQXY0074001	CRYSTAL	QX-074 10.240MHZ	X302	1
AT370ZHBAE	BQXY0796001	CRYSTAL	QX-796 4.258996MHZ	X301	1
AT370ZHBAE	BRFC160004Z	R:CARBON FIXED CHIP	0 1/16W J TAPE	R017	1
AT370ZHBAE	BRFC160004Z	R:CARBON FIXED CHIP	0 1/16W J TAPE	R400	1
AT370ZHBAE	BRFC161004Z	R:CARBON FIXED CHIP	10 1/16W J TAPE	R015	1
AT370ZHBAE	BRFC161014Z	R:CARBON FIXED CHIP	100 1/16W J TAPE	R007	1
AT370ZHBAE	BRFC161014Z	R:CARBON FIXED CHIP	100 1/16W J TAPE	R012	1
AT370ZHBAE	BRFC161014Z	R:CARBON FIXED CHIP	100 1/16W J TAPE	R019	1
AT370ZHBAE	BRFC161014Z	R:CARBON FIXED CHIP	100 1/16W J TAPE	R026	1
AT370ZHBAE	BRFC161014Z	R:CARBON FIXED CHIP	100 1/16W J TAPE	R067	1
AT370ZHBAE	BRFC161014Z	R:CARBON FIXED CHIP	100 1/16W J TAPE	R087	1
AT370ZHBAE	BRFC161014Z	R:CARBON FIXED CHIP	100 1/16W J TAPE	R203	1
AT370ZHBAE	BRFC161024Z	R:CARBON FIXED CHIP	1K 1/16W J TAPE	R002	1
AT370ZHBAE	BRFC161024Z	R:CARBON FIXED CHIP	1K 1/16W J TAPE	R016	1
AT370ZHBAE	BRFC161024Z	R:CARBON FIXED CHIP	1K 1/16W J TAPE	R236	1
AT370ZHBAE	BRFC161024Z	R:CARBON FIXED CHIP	1K 1/16W J TAPE	R244	1
AT370ZHBAE	BRFC161024Z	R:CARBON FIXED CHIP	1K 1/16W J TAPE	R246	1
AT370ZHBAE	BRFC161024Z	R:CARBON FIXED CHIP	1K 1/16W J TAPE	R301	1
AT370ZHBAE	BRFC161024Z	R:CARBON FIXED CHIP	1K 1/16W J TAPE	R303	1
AT370ZHBAE	BRFC161024Z	R:CARBON FIXED CHIP	1K 1/16W J TAPE	R304	1
AT370ZHBAE	BRFC161024Z	R:CARBON FIXED CHIP	1K 1/16W J TAPE	R305	1
AT370ZHBAE	BRFC161024Z	R:CARBON FIXED CHIP	1K 1/16W J TAPE	R307	1
AT370ZHBAE	BRFC161024Z	R:CARBON FIXED CHIP	1K 1/16W J TAPE	R318	1
AT370ZHBAE	BRFC161024Z	R:CARBON FIXED CHIP	1K 1/16W J TAPE	R324	1
AT370ZHBAE	BRFC161024Z	R:CARBON FIXED CHIP	1K 1/16W J TAPE	R325	1

MODEL	HARRY II ASC	TOTAL	711		
ASSY CODE	PARTS CODE	DESCRIPTION	SPEC	REF NO	QTY
AT370ZHBAE	BRFC161044Z	R:CARBON FIXED CHIP	100K 1/16W J TAPE	R031	1
AT370ZHBAE	BRFC161044Z	R:CARBON FIXED CHIP	100K 1/16W J TAPE	R032	1
AT370ZHBAE	BRFC161044Z	R:CARBON FIXED CHIP	100K 1/16W J TAPE	R059	1
AT370ZHBAE	BRFC161044Z	R:CARBON FIXED CHIP	100K 1/16W J TAPE	R061	1
AT370ZHBAE	BRFC161044Z	R:CARBON FIXED CHIP	100K 1/16W J TAPE	R348	1
AT370ZHBAE	BRFC161054Z	R:CARBON FIXED CHIP	1M 1/16W J TAPE	R038	1
AT370ZHBAE	BRFC161054Z	R:CARBON FIXED CHIP	1M 1/16W J TAPE	R039	1
AT370ZHBAE	BRFC161054Z	R:CARBON FIXED CHIP	1M 1/16W J TAPE	R046	1
AT370ZHBAE	BRFC161054Z	R:CARBON FIXED CHIP	1M 1/16W J TAPE	R326	1
AT370ZHBAE	BRFC161054Z	R:CARBON FIXED CHIP	1M 1/16W J TAPE	R329	1
AT370ZHBAE	BRFC161054Z	R:CARBON FIXED CHIP	1M 1/16W J TAPE	R336	1
AT370ZHBAE	BRFC161514Z	R:CARBON FIXED CHIP	150 1/16W J TAPE	R022	1
AT370ZHBAE	BRFC161514Z	R:CARBON FIXED CHIP	150 1/16W J TAPE	R028	1
AT370ZHBAE	BRFC161514Z	R:CARBON FIXED CHIP	150 1/16W J TAPE	R252	1
AT370ZHBAE	BRFC161524Z	R:CARBON FIXED CHIP	1.5K 1/16W J TAPE	R065	1
AT370ZHBAE	BRFC161524Z	R:CARBON FIXED CHIP	1.5K 1/16W J TAPE	R091	1
AT370ZHBAE	BRFC161524Z	R:CARBON FIXED CHIP	1.5K 1/16W J TAPE	R221	1
AT370ZHBAE	BRFC161524Z	R:CARBON FIXED CHIP	1.5K 1/16W J TAPE	R233	1
AT370ZHBAE	BRFC161524Z	R:CARBON FIXED CHIP	1.5K 1/16W J TAPE	R247	1
AT370ZHBAE	BRFC161524Z	R:CARBON FIXED CHIP	1.5K 1/16W J TAPE	R376	1
AT370ZHBAE	BRFC161534Z	R:CARBON FIXED CHIP	15K 1/16W J TAPE	R021	1
AT370ZHBAE	BRFC161534Z	R:CARBON FIXED CHIP	15K 1/16W J TAPE	R033	1
AT370ZHBAE	BRFC161534Z	R:CARBON FIXED CHIP	15K 1/16W J TAPE	R092	1
AT370ZHBAE	BRFC161544Z	R:CARBON FIXED CHIP	150K 1/16W J TAPE	R034	1
AT370ZHBAE	BRFC161554Z	R:CARBON FIXED CHIP	1.5M 1/16W J TAPE	R071	1
AT370ZHBAE	BRFC161824Z	R:CARBON FIXED CHIP	1.8K 1/16W J TAPE	R013	1
AT370ZHBAE	BRFC161824Z	R:CARBON FIXED CHIP	1.8K 1/16W J TAPE	R210	1
AT370ZHBAE	BRFC162204Z	R:CARBON FIXED CHIP	22 1/16W J TAPE	R207	1
AT370ZHBAE	BRFC162214Z	R:CARBON FIXED CHIP	220 1/16W J TAPE	R018	1
AT370ZHBAE	BRFC162214Z	R:CARBON FIXED CHIP	220 1/16W J TAPE	R080	1
AT370ZHBAE	BRFC162214Z	R:CARBON FIXED CHIP	220 1/16W J TAPE	R084	1
AT370ZHBAE	BRFC162214Z	R:CARBON FIXED CHIP	220 1/16W J TAPE	R088	1
AT370ZHBAE	BRFC162214Z	R:CARBON FIXED CHIP	220 1/16W J TAPE	R094	1
AT370ZHBAE	BRFC162214Z	R:CARBON FIXED CHIP	220 1/16W J TAPE	R211	1
AT370ZHBAE	BRFC162214Z	R:CARBON FIXED CHIP	220 1/16W J TAPE	R214	1
AT370ZHBAE	BRFC162214Z	R:CARBON FIXED CHIP	220 1/16W J TAPE	R363	1
AT370ZHBAE	BRFC162224Z	R:CARBON FIXED CHIP	2.2K 1/16W J TAPE	R003	1
AT370ZHBAE	BRFC162224Z	R:CARBON FIXED CHIP	2.2K 1/16W J TAPE	R005	1
AT370ZHBAE	BRFC162224Z	R:CARBON FIXED CHIP	2.2K 1/16W J TAPE	R020	1
AT370ZHBAE	BRFC162224Z	R:CARBON FIXED CHIP	2.2K 1/16W J TAPE	R027	1
AT370ZHBAE	BRFC162224Z	R:CARBON FIXED CHIP	2.2K 1/16W J TAPE	R226	1
AT370ZHBAE	BRFC162224Z	R:CARBON FIXED CHIP	2.2K 1/16W J TAPE	R229	1
AT370ZHBAE	BRFC162224Z	R:CARBON FIXED CHIP	2.2K 1/16W J TAPE	R231	1
AT370ZHBAE	BRFC162224Z	R:CARBON FIXED CHIP	2.2K 1/16W J TAPE	R235	1
AT370ZHBAE	BRFC162224Z	R:CARBON FIXED CHIP	2.2K 1/16W J TAPE	R251	1
AT370ZHBAE	BRFC162224Z	R:CARBON FIXED CHIP	2.2K 1/16W J TAPE	R253	1
AT370ZHBAE	BRFC162224Z	R:CARBON FIXED CHIP	2.2K 1/16W J TAPE	R260	1
AT370ZHBAE	BRFC162224Z	R:CARBON FIXED CHIP	2.2K 1/16W J TAPE	R261	1
AT370ZHBAE	BRFC162224Z	R:CARBON FIXED CHIP	2.2K 1/16W J TAPE	R262	1
AT370ZHBAE	BRFC162224Z	R:CARBON FIXED CHIP	2.2K 1/16W J TAPE	R300	1
AT370ZHBAE	BRFC162224Z	R:CARBON FIXED CHIP	2.2K 1/16W J TAPE	R302	1
AT370ZHBAE	BRFC162224Z	R:CARBON FIXED CHIP	2.2K 1/16W J TAPE	R320	1
AT370ZHBAE	BRFC162224Z	R:CARBON FIXED CHIP	2.2K 1/16W J TAPE	R323	1
AT370ZHBAE	BRFC162224Z	R:CARBON FIXED CHIP	2.2K 1/16W J TAPE	R330	1
AT370ZHBAE	BRFC162224Z	R:CARBON FIXED CHIP	2.2K 1/16W J TAPE	R331	1
AT370ZHBAE	BRFC162224Z	R:CARBON FIXED CHIP	2.2K 1/16W J TAPE	R332	1
AT370ZHBAE	BRFC162224Z	R:CARBON FIXED CHIP	2.2K 1/16W J TAPE	R410	1
AT370ZHBAE	BRFC162234Z	R:CARBON FIXED CHIP	22K 1/16W J TAPE	R049	1
AT370ZHBAE	BRFC162234Z	R:CARBON FIXED CHIP	22K 1/16W J TAPE	R213	1
AT370ZHBAE	BRFC162234Z	R:CARBON FIXED CHIP	22K 1/16W J TAPE	R345	1
AT370ZHBAE	BRFC162234Z	R:CARBON FIXED CHIP	22K 1/16W J TAPE	R364	1
AT370ZHBAE	BRFC162244Z	R:CARBON FIXED CHIP	220K 1/16W J TAPE	R234	1
AT370ZHBAE	BRFC162244Z	R:CARBON FIXED CHIP	220K 1/16W J TAPE	R402	1
AT370ZHBAE	BRFC162254Z	R:CARBON FIXED CHIP	2.2M 1/16W J TAPE	R056	1

MODEL	HARRY II ASC	TOTAL	711		
ASSY CODE	PARTS CODE	DESCRIPTION	SPEC	REF NO	QTY
AT370ZHBAE	BRFC162294Z	R:CARBON FIXED CHIP	2.2 1/16W J TAPE	R076	1
AT370ZHBAE	BRFC162714Z	R:CARBON FIXED CHIP	270 1/16W J TAPE	R009	1
AT370ZHBAE	BRFC162714Z	R:CARBON FIXED CHIP	270 1/16W J TAPE	R011	1
AT370ZHBAE	BRFC162714Z	R:CARBON FIXED CHIP	270 1/16W J TAPE	R309	1
AT370ZHBAE	BRFC162714Z	R:CARBON FIXED CHIP	270 1/16W J TAPE	R310	1
AT370ZHBAE	BRFC162714Z	R:CARBON FIXED CHIP	270 1/16W J TAPE	R311	1
AT370ZHBAE	BRFC162714Z	R:CARBON FIXED CHIP	270 1/16W J TAPE	R312	1
AT370ZHBAE	BRFC162714Z	R:CARBON FIXED CHIP	270 1/16W J TAPE	R313	1
AT370ZHBAE	BRFC162714Z	R:CARBON FIXED CHIP	270 1/16W J TAPE	R314	1
AT370ZHBAE	BRFC162714Z	R:CARBON FIXED CHIP	270 1/16W J TAPE	R315	1
AT370ZHBAE	BRFC162714Z	R:CARBON FIXED CHIP	270 1/16W J TAPE	R316	1
AT370ZHBAE	BRFC162714Z	R:CARBON FIXED CHIP	270 1/16W J TAPE	R371	1
AT370ZHBAE	BRFC162724Z	R:CARBON FIXED CHIP	2.7K 1/16W J TAPE	R074	1
AT370ZHBAE	BRFC162724Z	R:CARBON FIXED CHIP	2.7K 1/16W J TAPE	R407	1
AT370ZHBAE	BRFC162744Z	R:CARBON FIXED CHIP	270K 1/16W J TAPE	R045	1
AT370ZHBAE	BRFC163304Z	R:CARBON FIXED CHIP	33 1/16W J TAPE	R204	1
AT370ZHBAE	BRFC163304Z	R:CARBON FIXED CHIP	33 1/16W J TAPE	R206	1
AT370ZHBAE	BRFC163314Z	R:CARBON FIXED CHIP	330 1/16W J TAPE	R230	1
AT370ZHBAE	BRFC163324Z	R:CARBON FIXED CHIP	3.3K 1/16W J TAPE	R062	1
AT370ZHBAE	BRFC163324Z	R:CARBON FIXED CHIP	3.3K 1/16W J TAPE	R066	1
AT370ZHBAE	BRFC163324Z	R:CARBON FIXED CHIP	3.3K 1/16W J TAPE	R209	1
AT370ZHBAE	BRFC163324Z	R:CARBON FIXED CHIP	3.3K 1/16W J TAPE	R248	1
AT370ZHBAE	BRFC163324Z	R:CARBON FIXED CHIP	3.3K 1/16W J TAPE	R357	1
AT370ZHBAE	BRFC163324Z	R:CARBON FIXED CHIP	3.3K 1/16W J TAPE	R380	1
AT370ZHBAE	BRFC163324Z	R:CARBON FIXED CHIP	3.3K 1/16W J TAPE	R388	1
AT370ZHBAE	BRFC163324Z	R:CARBON FIXED CHIP	3.3K 1/16W J TAPE	R389	1
AT370ZHBAE	BRFC163334Z	R:CARBON FIXED CHIP	33K 1/16W J TAPE	R051	1
AT370ZHBAE	BRFC163334Z	R:CARBON FIXED CHIP	33K 1/16W J TAPE	R069	1
AT370ZHBAE	BRFC163334Z	R:CARBON FIXED CHIP	33K 1/16W J TAPE	R217	1
AT370ZHBAE	BRFC163334Z	R:CARBON FIXED CHIP	33K 1/16W J TAPE	R239	1
AT370ZHBAE	BRFC163334Z	R:CARBON FIXED CHIP	33K 1/16W J TAPE	R240	1
AT370ZHBAE	BRFC163334Z	R:CARBON FIXED CHIP	33K 1/16W J TAPE	R255	1
AT370ZHBAE	BRFC163394Z	R:CARBON FIXED CHIP	3.3 1/16W J TAPE	R090	1
AT370ZHBAE	BRFC163394Z	R:CARBON FIXED CHIP	3.3 1/16W J TAPE	R205	1
AT370ZHBAE	BRFC163914Z	R:CARBON FIXED CHIP	390 1/16W J TAPE	R223	1
AT370ZHBAE	BRFC163914Z	R:CARBON FIXED CHIP	390 1/16W J TAPE	R362	1
AT370ZHBAE	BRFC163914Z	R:CARBON FIXED CHIP	390 1/16W J TAPE	R408	1
AT370ZHBAE	BRFC163914Z	R:CARBON FIXED CHIP	390 1/16W J TAPE	R411	1
AT370ZHBAE	BRFC163924Z	R:CARBON FIXED CHIP	3.9K 1/16W J TAPE	R334	1
AT370ZHBAE	BRFC163924Z	R:CARBON FIXED CHIP	3.9K 1/16W J TAPE	R347	1
AT370ZHBAE	BRFC163924Z	R:CARBON FIXED CHIP	3.9K 1/16W J TAPE	R359	1
AT370ZHBAE	BRFC163934Z	R:CARBON FIXED CHIP	39K 1/16W J TAPE	R238	1
AT370ZHBAE	BRFC163934Z	R:CARBON FIXED CHIP	39K 1/16W J TAPE	R249	1
AT370ZHBAE	BRFC163934Z	R:CARBON FIXED CHIP	39K 1/16W J TAPE	R413	1
AT370ZHBAE	BRFC163944Z	R:CARBON FIXED CHIP	390K 1/16W J TAPE	R036	1
AT370ZHBAE	BRFC164704Z	R:CARBON FIXED CHIP	47 1/16W J TAPE	R035	1
AT370ZHBAE	BRFC164704Z	R:CARBON FIXED CHIP	47 1/16W J TAPE	R075	1
AT370ZHBAE	BRFC164714Z	R:CARBON FIXED CHIP	470 1/16W J TAPE	R089	1
AT370ZHBAE	BRFC164714Z	R:CARBON FIXED CHIP	470 1/16W J TAPE	R360	1
AT370ZHBAE	BRFC164714Z	R:CARBON FIXED CHIP	470 1/16W J TAPE	R396	1
AT370ZHBAE	BRFC164724Z	R:CARBON FIXED CHIP	4.7K 1/16W J TAPE	R024	1
AT370ZHBAE	BRFC164724Z	R:CARBON FIXED CHIP	4.7K 1/16W J TAPE	R043	1
AT370ZHBAE	BRFC164724Z	R:CARBON FIXED CHIP	4.7K 1/16W J TAPE	R057	1
AT370ZHBAE	BRFC164724Z	R:CARBON FIXED CHIP	4.7K 1/16W J TAPE	R073	1
AT370ZHBAE	BRFC164724Z	R:CARBON FIXED CHIP	4.7K 1/16W J TAPE	R095	1
AT370ZHBAE	BRFC164724Z	R:CARBON FIXED CHIP	4.7K 1/16W J TAPE	R245	1
AT370ZHBAE	BRFC164724Z	R:CARBON FIXED CHIP	4.7K 1/16W J TAPE	R306	1
AT370ZHBAE	BRFC164724Z	R:CARBON FIXED CHIP	4.7K 1/16W J TAPE	R355	1
AT370ZHBAE	BRFC164734Z	R:CARBON FIXED CHIP	47K 1/16W J TAPE	R023	1
AT370ZHBAE	BRFC164734Z	R:CARBON FIXED CHIP	47K 1/16W J TAPE	R058	1
AT370ZHBAE	BRFC164734Z	R:CARBON FIXED CHIP	47K 1/16W J TAPE	R215	1
AT370ZHBAE	BRFC164734Z	R:CARBON FIXED CHIP	47K 1/16W J TAPE	R259	1
AT370ZHBAE	BRFC164734Z	R:CARBON FIXED CHIP	47K 1/16W J TAPE	R319	1
AT370ZHBAE	BRFC164734Z	R:CARBON FIXED CHIP	47K 1/16W J TAPE	R354	1

MODEL	HARRY II ASC	TOTAL	711		
ASSY CODE	PARTS CODE	DESCRIPTION	SPEC	REF NO	QTY
AT370ZHBAE	BRFC164734Z	R:CARBON FIXED CHIP	47K 1/16W J TAPE	R358	1
AT370ZHBAE	BRFC164734Z	R:CARBON FIXED CHIP	47K 1/16W J TAPE	R361	1
AT370ZHBAE	BRFC164734Z	R:CARBON FIXED CHIP	47K 1/16W J TAPE	R370	1
AT370ZHBAE	BRFC164744Z	R:CARBON FIXED CHIP	470K 1/16W J TAPE	R040	1
AT370ZHBAE	BRFC165604Z	R:CARBON FIXED CHIP	56 1/16W J TAPE	R077	1
AT370ZHBAE	BRFC165604Z	R:CARBON FIXED CHIP	56 1/16W J TAPE	R093	1
AT370ZHBAE	BRFC165604Z	R:CARBON FIXED CHIP	56 1/16W J TAPE	R208	1
AT370ZHBAE	BRFC165604Z	R:CARBON FIXED CHIP	56 1/16W J TAPE	R212	1
AT370ZHBAE	BRFC165614Z	R:CARBON FIXED CHIP	560 1/16W J TAPE	R010	1
AT370ZHBAE	BRFC165614Z	R:CARBON FIXED CHIP	560 1/16W J TAPE	R014	1
AT370ZHBAE	BRFC165614Z	R:CARBON FIXED CHIP	560 1/16W J TAPE	R025	1
AT370ZHBAE	BRFC165614Z	R:CARBON FIXED CHIP	560 1/16W J TAPE	R041	1
AT370ZHBAE	BRFC165614Z	R:CARBON FIXED CHIP	560 1/16W J TAPE	R047	1
AT370ZHBAE	BRFC165614Z	R:CARBON FIXED CHIP	560 1/16W J TAPE	R202	1
AT370ZHBAE	BRFC165624Z	R:CARBON FIXED CHIP	5.6K 1/16W J TAPE	R042	1
AT370ZHBAE	BRFC165624Z	R:CARBON FIXED CHIP	5.6K 1/16W J TAPE	R044	1
AT370ZHBAE	BRFC165624Z	R:CARBON FIXED CHIP	5.6K 1/16W J TAPE	R072	1
AT370ZHBAE	BRFC165624Z	R:CARBON FIXED CHIP	5.6K 1/16W J TAPE	R224	1
AT370ZHBAE	BRFC165624Z	R:CARBON FIXED CHIP	5.6K 1/16W J TAPE	R237	1
AT370ZHBAE	BRFC165624Z	R:CARBON FIXED CHIP	5.6K 1/16W J TAPE	R243	1
AT370ZHBAE	BRFC165624Z	R:CARBON FIXED CHIP	5.6K 1/16W J TAPE	R254	1
AT370ZHBAE	BRFC165624Z	R:CARBON FIXED CHIP	5.6K 1/16W J TAPE	R377	1
AT370ZHBAE	BRFC165624Z	R:CARBON FIXED CHIP	5.6K 1/16W J TAPE	R405	1
AT370ZHBAE	BRFC165634Z	R:CARBON FIXED CHIP	56K 1/16W J TAPE	R037	1
AT370ZHBAE	BRFC165634Z	R:CARBON FIXED CHIP	56K 1/16W J TAPE	R083	1
AT370ZHBAE	BRFC165634Z	R:CARBON FIXED CHIP	56K 1/16W J TAPE	R085	1
AT370ZHBAE	BRFC165644Z	R:CARBON FIXED CHIP	560K 1/16W J TAPE	R064	1
AT370ZHBAE	BRFC165644Z	R:CARBON FIXED CHIP	560K 1/16W J TAPE	R419	1
AT370ZHBAE	BRFC166814Z	R:CARBON FIXED CHIP	680 1/16W J TAPE	R006	1
AT370ZHBAE	BRFC166814Z	R:CARBON FIXED CHIP	680 1/16W J TAPE	R321	1
AT370ZHBAE	BRFC166814Z	R:CARBON FIXED CHIP	680 1/16W J TAPE	R322	1
AT370ZHBAE	BRFC166814Z	R:CARBON FIXED CHIP	680 1/16W J TAPE	R368	1
AT370ZHBAE	BRFC166814Z	R:CARBON FIXED CHIP	680 1/16W J TAPE	R372	1
AT370ZHBAE	BRFC166824Z	R:CARBON FIXED CHIP	6.8K 1/16W J TAPE	R004	1
AT370ZHBAE	BRFC166824Z	R:CARBON FIXED CHIP	6.8K 1/16W J TAPE	R068	1
AT370ZHBAE	BRFC166824Z	R:CARBON FIXED CHIP	6.8K 1/16W J TAPE	R070	1
AT370ZHBAE	BRFC166834Z	R:CARBON FIXED CHIP	68K 1/16W J TAPE	R030	1
AT370ZHBAE	BRFC166834Z	R:CARBON FIXED CHIP	68K 1/16W J TAPE	R409	1
AT370ZHBAE	BRFC166834Z	R:CARBON FIXED CHIP	68K 1/16W J TAPE	R412	1
AT370ZHBAE	BRFC168214Z	R:CARBON FIXED CHIP	820 1/16W J TAPE	R328	1
AT370ZHBAE	BRFC168224Z	R:CARBON FIXED CHIP	8.2K 1/16W J TAPE	R008	1
AT370ZHBAE	BRFC168224Z	R:CARBON FIXED CHIP	8.2K 1/16W J TAPE	R055	1
AT370ZHBAE	BRFC168224Z	R:CARBON FIXED CHIP	8.2K 1/16W J TAPE	R216	1
AT370ZHBAE	BRFC168234Z	R:CARBON FIXED CHIP	82K 1/16W J TAPE	R082	1
AT370ZHBAE	BRFC188204Z	R:CARBON FIXED CHIP	82 1/8W J TAPE	R375	1
AT370ZHBAE	BRFT141034Z	R:CARBON AXIAL LEAD (52)	10K 1/4W J TAPE	R378	1
AT370ZHBAE	BRFT141034Z	R:CARBON AXIAL LEAD (52)	10K 1/4W J TAPE	R398	1
AT370ZHBAE	BRFT141044Z	R:CARBON AXIAL LEAD (52)	100K 1/4W J TAPE	R060	1
AT370ZHBAE	BRFT143334Z	R:CARBON AXIAL LEAD (52)	33K 1/4W J TAPE	R054	1
AT370ZHBAE	BRPA611034Z	R:CARBON AXIAL LEAD (26)	10K 1/6W J TAPE	R335	1
AT370ZHBAE	BRPA611034Z	R:CARBON AXIAL LEAD (26)	10K 1/6W J TAPE	R338	1
AT370ZHBAE	BRPA611034Z	R:CARBON AXIAL LEAD (26)	10K 1/6W J TAPE	R340	1
AT370ZHBAE	BRPA615614Z	R:CARBON AXIAL LEAD (26)	560 1/6W J TAPE	R232	1
AT370ZHBAE	BRSJ001014Z	R:METAL OXIDE	100 1WS J	R220	1
AT370ZHBAE	BRSJ005604Z	RESISTOR:METAL OXIDE	56 1WS J	R395	1
AT370ZHBAE	BRSJ008204Z	R:METAL OXIDE	82 1WS J	R218	1
AT370ZHBAE	BRSJ008204Z	R:METAL OXIDE	82 1WS J	R219	1
AT370ZHBAE	BRSJ034794Z	RESISTOR:METAL OXIDE	4.7 3WS J	R086	1
AT370ZHBAE	BRTY0569102	R:SEMI-FIXED	RT-569 PVZ3A102A01R00	RT204	1
AT370ZHBAE	BRTY0569102	R:SEMI-FIXED	RT-569 PVZ3A102A01R00	RT401	1
AT370ZHBAE	BRTY0569103	R:SEMI-FIXED	RT-569 PVZ3A103A01R00	RT201	1
AT370ZHBAE	BRTY0569222	R:SEMI-FIXED	RT-569 PVZ3A222A01R00	RT001	1
AT370ZHBAE	BRTY0569222	R:SEMI-FIXED	RT-569 PVZ3A222A01R00	RT002	1
AT370ZHBAE	BRTY0569222	R:SEMI-FIXED	RT-569 PVZ3A222A01R00	RT202	1

MODEL	HARRY II ASC	TOTAL	711		
ASSY CODE	PARTS CODE	DESCRIPTION	SPEC	REF NO	QTY
AT370ZHBAE	BRTY0569222	R:SEMI-FIXED	RT-569 PVZ3A222A01R00	RT203	1
AT370ZHBAE	BRTY0569222	R:SEMI-FIXED	RT-569 PVZ3A222A01R00	RT205	1
AT370ZHBAE	BRTY0569472	R:SEMI-FIXED	RT-569 PVZ3A472A01R00	RT206	1
AT370ZHBAE	BTFY0157001	TRANSFORMER:AF CHOKE	TF-157	T301	1
AT370ZHBAE	BTFY0215001	TRANS	TF-215	T302	1
AT370ZHBAE	BTPY0122001	TEST PIN	TP-122 1820-01-PP1	TP001	1
AT370ZHBAM	HHSK352447Z	HEAT SINK (COMP)	C2680(BSP)		1
AT370ZHBAM	HHSK452777Z	HEAT SINK	C2680(BSP)		0
AT370ZHBAM	HHSK452778Z	HEAT SINK	C2680(BSP)		0
AT370ZHBAM	HSDC452454Z	SHIELD CASE	SPTTE		1
AT370ZHBAW	CUAH014041Z	WIRE	UL1007 #24 10-140- 3 GR Y	W001	1
AT370ZHBAW	CUAJ014041Z	WIRE	UL 1007 #24 10-140- 3 WHT	W002	1
AT370ZHBAW	CUPJ003022Z	WIRE W-004	UL 1571 #26 5- 30- 5 WHT	W003	1
AT370ZHBBE	BCML811025Z	C:CERAMIC M/L (1608) TAPE	0.001UF 50V K B	C555	1
AT370ZHBBE	BCML811025Z	C:CERAMIC M/L (1608) TAPE	0.001UF 50V K B	C560	1
AT370ZHBBE	BCML811035Z	C:CERAMIC M/L (1608) TAPE	0.01UF 50V K B	C551	1
AT370ZHBBE	BCML811035Z	C:CERAMIC M/L (1608) TAPE	0.01UF 50V K B	C552	1
AT370ZHBBE	BCML811035Z	C:CERAMIC M/L (1608) TAPE	0.01UF 50V K B	C553	1
AT370ZHBBE	BCML811035Z	C:CERAMIC M/L (1608) TAPE	0.01UF 50V K B	C554	1
AT370ZHBBE	BCML811035Z	C:CERAMIC M/L (1608) TAPE	0.01UF 50V K B	C556	1
AT370ZHBBE	BCML811035Z	C:CERAMIC M/L (1608) TAPE	0.01UF 50V K B	C557	1
AT370ZHBBE	BCML811035Z	C:CERAMIC M/L (1608) TAPE	0.01UF 50V K B	C558	1
AT370ZHBBE	BCML811035Z	C:CERAMIC M/L (1608) TAPE	0.01UF 50V K B	C559	1
AT370ZHBBE	BDAG1261001	DIODE:LED	DA-1261 BD2-40TYG-A12U	D551	1
AT370ZHBBE	BDAY1082015	DIODE:ZENER	UDZS7.5B TE-17	D552	1
AT370ZHBBE	BDAY1082015	DIODE:ZENER	UDZS7.5B TE-17	D553	1
AT370ZHBBE	BDAY1082015	DIODE:ZENER	UDZS7.5B TE-17	D554	1
AT370ZHBBE	BLDY0087001	COIL	LD-087 BF04-3*5*1	L551	1
AT370ZHBBE	BLDY0087001	COIL	LD-087 BF04-3*5*1	L554	1
AT370ZHBBE	BLDY0087001	COIL	LD-087 BF04-3*5*1	L555	1
AT370ZHBBE	BLZY0041100	INDUCTOR:MOLDED	LZ-041 10UH K	L552	1
AT370ZHBBE	BLZY0041100	INDUCTOR:MOLDED	LZ-041 10UH K	L553	1
AT370ZHBBE	BPAG0435AA2	PCB:FRONT	PA-435AA 2/4	B551	1
AT370ZHBBE	BRFC161024Z	R:CARBON FIXED CHIP	1K 1/16W J TAPE	R551	1
AT370ZHBBE	BRFC161024Z	R:CARBON FIXED CHIP	1K 1/16W J TAPE	R552	1
AT370ZHBBE	BRFC161024Z	R:CARBON FIXED CHIP	1K 1/16W J TAPE	R553	1
AT370ZHBBE	BRFC161024Z	R:CARBON FIXED CHIP	1K 1/16W J TAPE	R555	1
AT370ZHBBE	BRFC164724Z	R:CARBON FIXED CHIP	4.7K 1/16W J TAPE	R556	1
AT370ZHBBE	BRFC166824Z	R:CARBON FIXED CHIP	6.8K 1/16W J TAPE	R554	1
AT370ZHBBE	BSWY0557001	SWITCH:SLIDE	SW-557 SSFYP22-14.5B	S551	1
AT370ZHBBE	BSWY0557001	SWITCH:SLIDE	SW-557 SSFYP22-14.5B	S552	1
AT370ZHBBE	BSWY0557001	SWITCH:SLIDE	SW-557 SSFYP22-14.5B	S553	1
AT370ZHBBM	GHDL418694A	HOLDER:LED	ABS BLACK		1
AT370ZHBCE	BCML811035Z	C:CERAMIC M/L (1608) TAPE	0.01UF 50V K B	C701	1
AT370ZHBCE	BCML811035Z	C:CERAMIC M/L (1608) TAPE	0.01UF 50V K B	C702	1
AT370ZHBCE	BPAG0435AA3	PCB:SW	PA-435AA 3/4	B701	1
AT370ZHBCE	BRFC161024Z	R:CARBON FIXED CHIP	1K 1/16W J TAPE	R701	1
AT370ZHBCE	BRFC161024Z	R:CARBON FIXED CHIP	1K 1/16W J TAPE	R702	1
AT370ZHBCE	BSRG0458001	SWITCH:ROTARY	SR-458 SR10030F-30F-F7-008	S701	1
AT370ZHBDE	BPAG0435AA4	PCB:VOLUME	PA-435AA 4/4	B801	1
AT370ZHBDE	BRVY0903001	R:VARIABLE(TP96N00N 25F A503)	RV-903 RY-6467 50KA/S	VR801	1
AT370ZHBDE	CZDZ072065Z	WIRES ASSEMBLED	W-072065	WA801	1
AT370ZHBYE	BDBB1135117	TRANSISTOR	DB-147 2SB1135R	Q503	1
AT370ZHBYE	BDBC2078105	TRANSISTOR	DB-791 2SC2078E	Q501	1
AT370ZHBYE	BDEY0919001	INTEGRATED CIRCUIT	IDA2003V	IC501	1
AT370ZHBYE	BDEY0924001	INTEGRATED CIRCUIT	L7808CV	IC502	1
AT370ZHBYE	BJKY0425002	JACK:W/O LUG	JK-425 M-RM-L 102	J501	1
AT370ZHBYE	BJKY0649001	JACK	JK-649 6S-L113-02A	J502	1
AT370ZHBYE	BRVY0672001	RESISTOR:VARIABLE	RV-672 5KB	VR501	1
AT370ZHBYE	BRVY0672001	RESISTOR:VARIABLE	RV-672 5KB	VR502	1
AT370ZHBYE	BSPY0238001	SPEAKER	SP-238 77R90T0403	SP501	1
AT370ZHBYE	BWZY1105001	CORD:DC CORD	WZ-1105 1500 W/P	WA501	1
AT370ZHBYE	BYDY0019003	BUSHING	YD-019 B312D-11-A	YI503	1
AT370ZHBYE	BYYY0027001	INSULATION SHEET	YY-027	Y501	1

MODEL	HARRY II ASC	TOTAL		711	
ASSY CODE	PARTS CODE	DESCRIPTION	SPEC	REF NO	QTY
AT370ZHBYE	BYYY0027001	INSULATION SHEET	YY-027	Y502	1
AT370ZHBYM	GCAS2B9768Z	PANEL:FRONT	ABS		1
AT370ZHBYM	GNBC418695Z	KNOB:CHANNEL	ABS,BLACK		1
AT370ZHBYM	GNBY418593A	KNOB	ABS,BLACK		3
AT370ZHBYM	HCAS3B9766Z	COVER:BOTTOM	VINY TOP		1
AT370ZHBYM	HCMT318698C	COVER:TOP	VINYTOP E,0.75T,BLACK		1
AT370ZHBYM	HCSY2B9763Z	CHASSIS	SECC		1
AT370ZHBYM	HHSK4B9767Z	HEAT SINK	A1070P(AL)		1
AT370ZHBYM	HSDC352448Z	SHIELD PLATE	C5210(PBSP)		1
AT370ZHBYM	KDPZ3C0840Z	PLATE:DISPLAY	PC		1
AT370ZHBYM	PLBS459497Z	LABEL:ID	**		1
AT370ZHBYM	PLBS459498Z	LABEL:ID	PAPER		2
AT370ZHBYM	PLBZ474165Z	LABEL:TA	**		1
AT370ZHBYM	PLBZ493436Z	CB STICKER (S)	**		1
AT370ZHBYM	PLBZ493437A	WIRING STICKER	**		1
AT370ZHBYM	PLBZ4B1100Z	LABEL:INDICATION	PAPER		1
AT370ZHBYM	RCUN4B9842Z	CUSHION	NEOPRENE		1
AT370ZHBYM	RCUN4C0269Z	CUSHION	NEOPRENE		1
AT370ZHBYM	RETC490493A	SPACER	WOOL TACK,0.5T,BLACK		2
AT370ZHBYM	RUTC418435Z	WOOL-COATED PAPER:WOOL TACK	WOOL PAPER,100*5*0.3T		4
AT370ZHBYM	SSCW133005N	SCREW:FLAT HD +	M3X5 NI	1	2
AT370ZHBYM	SSCW193008D	SCREW:BIND HD +	M3X8 BZMC	1	4
AT370ZHBYM	SSCW193008N	SCREW:BIND HD +	M3X8 NI	1	1
AT370ZHBYM	SSCW193010N	SCREW:BIND HD +	M3X10 NI	1	5
AT370ZHBYM	SSCW343006D	SCREW:TAPTIGHT BIND HD +	M3X6 BZMC	1	8
AT370ZHBYM	SSCW343006N	SCREW:TAPTIGHT BIND HD +	M3X6 NI	1	4
AT370ZHBYM	SSCW430030N	HEX NUT	M3.0 NI	1	5
AT370ZHBYM	SSCW480030Z	NUT:FLANGE	M3 ZMC	1	4
AT370ZHBYM	TSTD0200003	SPRING PLATE:KNOB	D6.02XL9.53		4
AT370ZHXYE	BMKY0540001	MICROPHONE	MK-540 EMC502-027	MC951	1
AT370ZHXYM	GMSC480407A	SCREW:MOUNTING	ABS,BLACK		2
AT370ZHXYM	HBCT418696A	MOUNTING BRACKET	SPCC 1.2T MFZN3		1
AT370ZHXYM	HMHG402919Z	HANGER:MICROPHONE	SPCC,1.0T,NI		1
AT370ZHXYM	SSCW293508N	SCREW:TAPPING ROUND HD +	D3.5X8 NI	1	2
AT370ZHXYM	SSCW295010N	SCREW:TAPPING ROUND HD +	D5X10 NI	1	2
AT370ZHXYM	SSCW530035N	WASHER:LOCK	D3.5 NI	1	2
AT370ZHXYM	SSCW540050N	WASHER:STAR	D5 NI	1	2
AT370ZHXYM	UTZZ01370ZZ	OWNERS MANUAL	**		1
AT370ZHXYM	VNYL2404080	VINYL BAG	400X400X800X0.07T		0,083
AT370ZHXYM	VNYL3101500	VINYL BAG	100X150X0.1T		1
AT370ZHXYM	VNYL3102500	VINYL BAG	100X250X0.1T		1
AT370ZHXYM	VNYL3203000	VINYL BAG	200X300X0.1T		2
AT370ZHXYM	WBXZ3C0002Z	DISPLAY BOX	**		1
AT370ZHXYM	WCTZ3C0281A	SHIPPING CARTON BOX	**		0,083
AT370ZHXYM	WSLV3C0280Z	SLEEVE	**		1
AT370ZHXYM	WSLV4C0278Z	SLEEVE	**		1
AT370ZHXYM	WSLV4C0279Z	SLEEVE	**		1

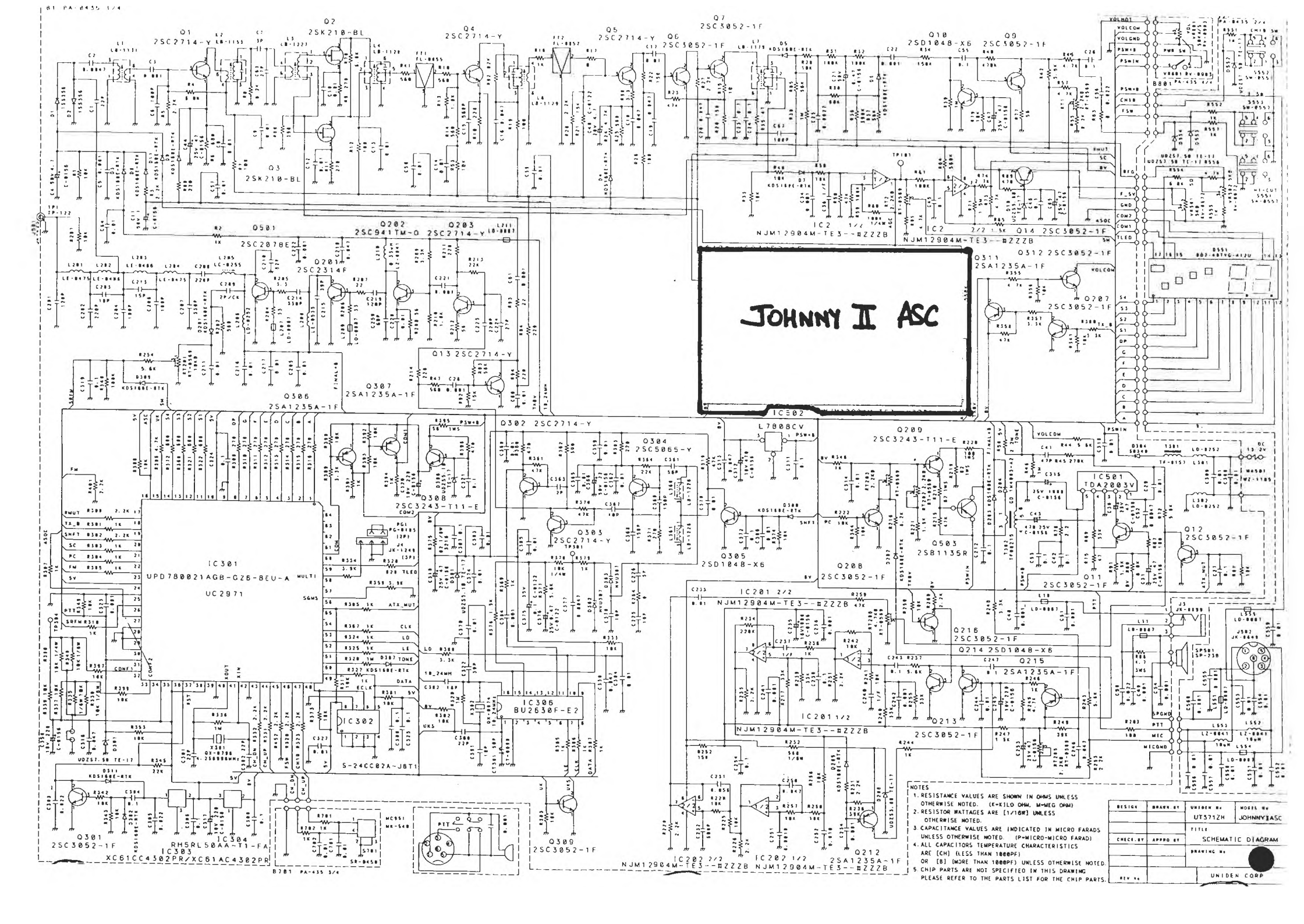

JOHNNY II ASC

- NOTES**
1. RESISTANCE VALUES ARE SHOWN IN OHMS UNLESS OTHERWISE NOTED. (K=KILO OHM, M=MEG OHM)
 2. RESISTOR WATTAGES ARE [1/10W] UNLESS OTHERWISE NOTED.
 3. CAPACITANCE VALUES ARE INDICATED IN MICRO FARADS UNLESS OTHERWISE NOTED. (P=PICO-MICRO FARAD)
 4. ALL CAPACITORS TEMPERATURE CHARACTERISTICS ARE [C] (LESS THAN 100PPF) OR [B] (MORE THAN 100PPF) UNLESS OTHERWISE NOTED.
 5. CHIP PARTS ARE NOT SPECIFIED IN THIS DRAWING. PLEASE REFER TO THE PARTS LIST FOR THE CHIP PARTS.

DESIGN	DRAWN BY	UNIDEN NO.	MODEL NO.
		UT5712H	JOHNNY2ASC
CHECK BY	APPROV BY	TITLE	
		SCHEMATIC DIAGRAM	
			DRAWING NO.
			UNIDEN CORP

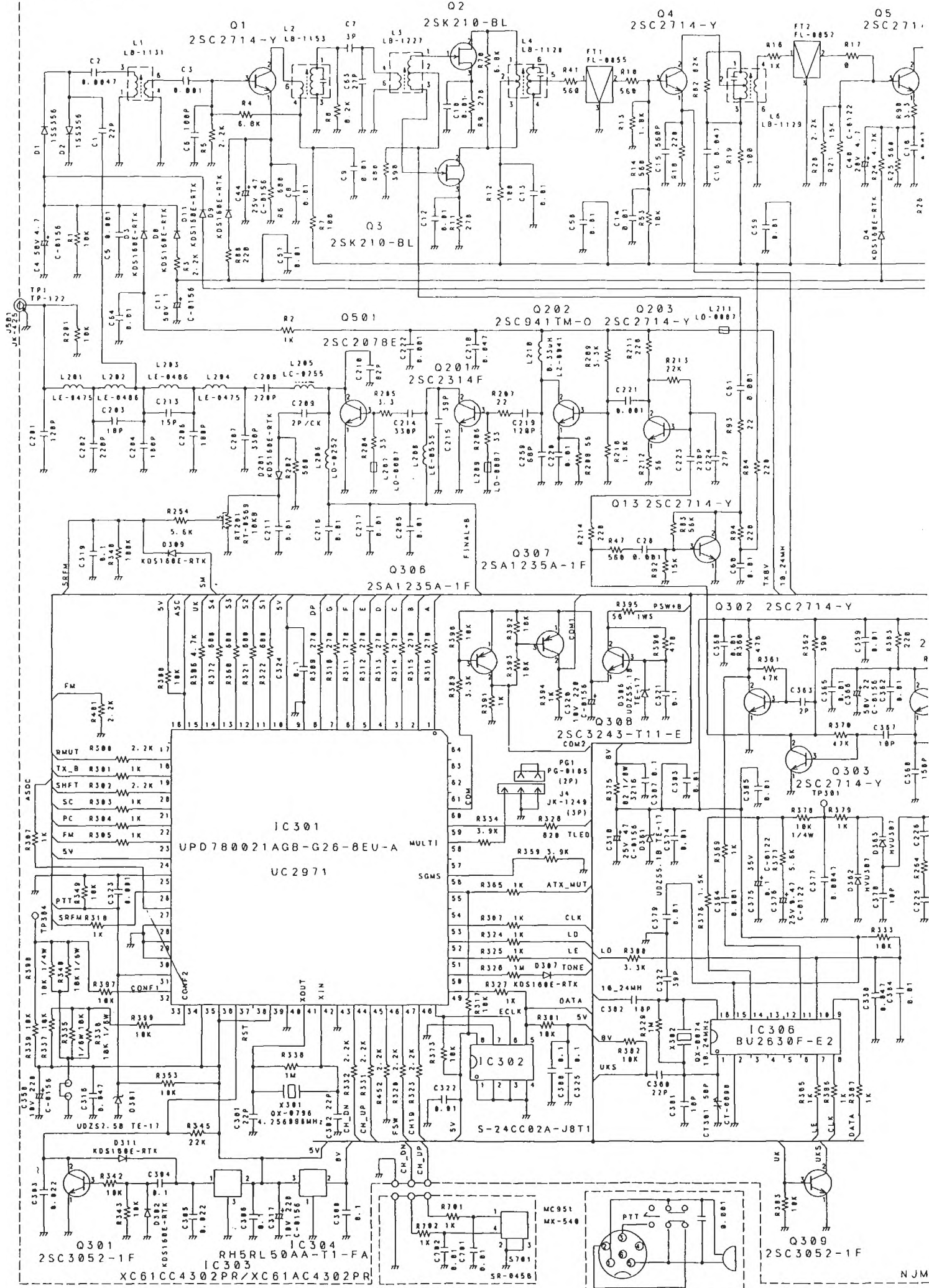

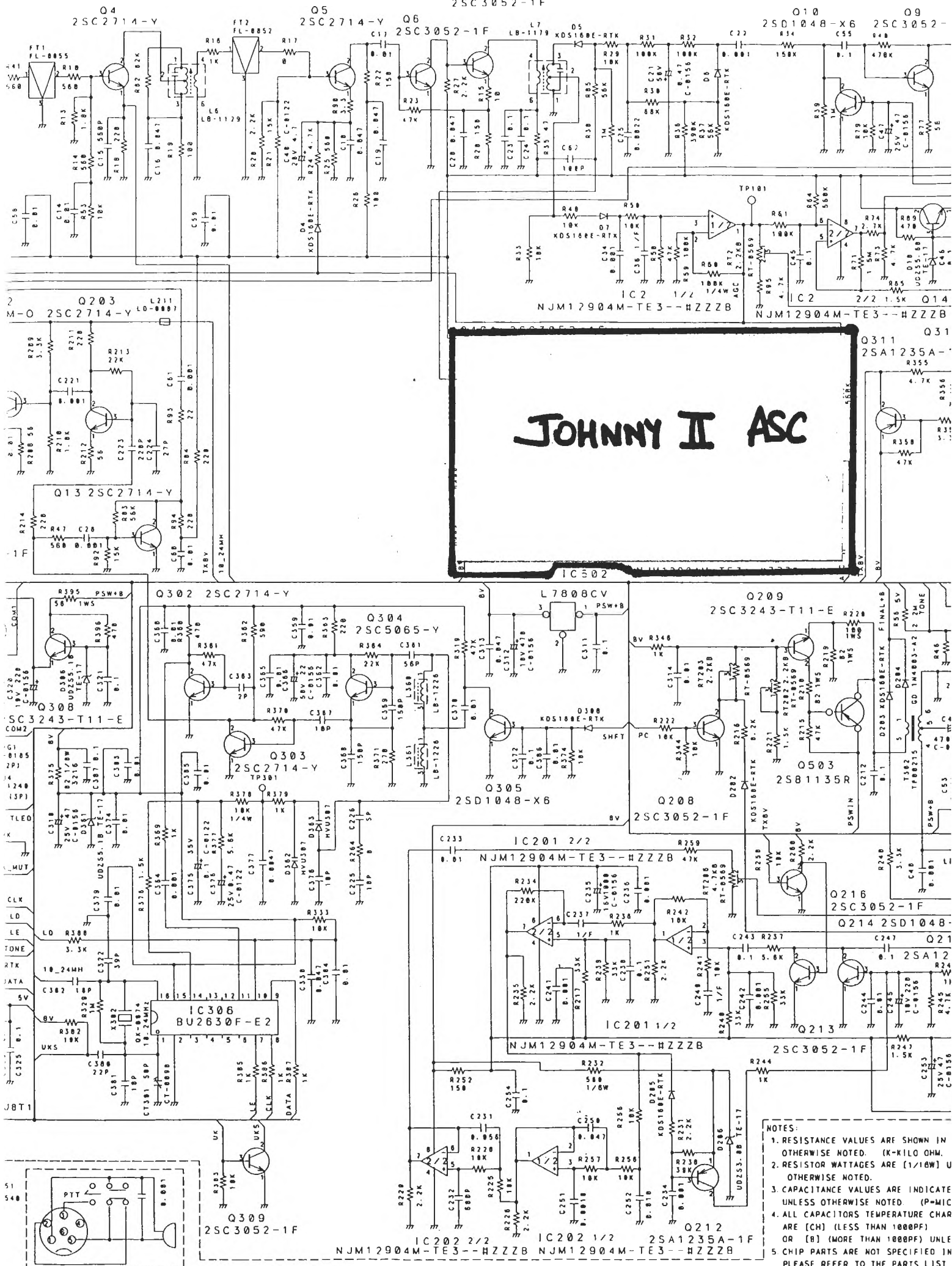

JOHNNY II ASC

- NOTES:
1. RESISTANCE VALUES ARE SHOWN IN OTHERWISE NOTED. (K=1000, M=1000000)
 2. RESISTOR WATTAGES ARE [1/16W] UNLESS OTHERWISE NOTED.
 3. CAPACITANCE VALUES INDICATE UNLESS OTHERWISE NOTED (P=MIC)
 4. ALL CAPACITORS TEMPERATURE CHAR ARE [CH] (LESS THAN 1000PF) OR [B] (MORE THAN 1000PF) UNLESS OTHERWISE NOTED.
 5. CHIP PARTS ARE NOT SPECIFIED IN THIS LIST PLEASE REFER TO THE PARTS LIST

JOHNNY II ASC

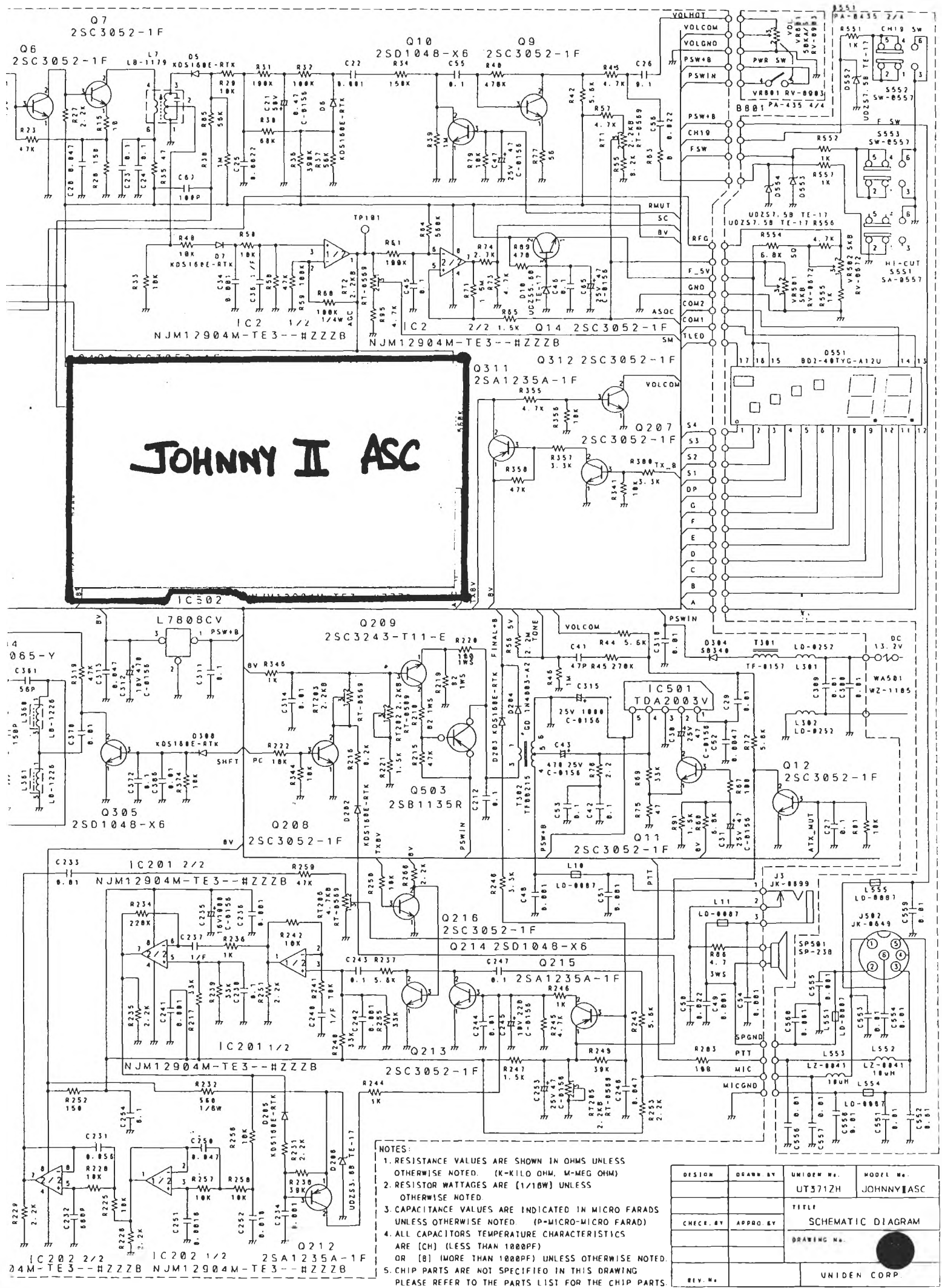

- NOTES:**
1. RESISTANCE VALUES ARE SHOWN IN OHMS UNLESS OTHERWISE NOTED. (K-KILO OHM, M-MEG OHM)
 2. RESISTOR WATTAGES ARE [1/16W] UNLESS OTHERWISE NOTED
 3. CAPACITANCE VALUES ARE INDICATED IN MICRO FARADS UNLESS OTHERWISE NOTED. (P-MICRO-MICRO FARAD)
 4. ALL CAPACITORS TEMPERATURE CHARACTERISTICS ARE [CH] (LESS THAN 1000PF) OR [0] (MORE THAN 1000PF) UNLESS OTHERWISE NOTED.
 5. CHIP PARTS ARE NOT SPECIFIED IN THIS DRAWING PLEASE REFER TO THE PARTS LIST FOR THE CHIP PARTS

DESIGN	DRAWN BY	UNIFORM NO.	MODEL NO.
		UT5712H	JOHNNY II ASC
TITLE			
SCHEMATIC DIAGRAM			
DRAWING No.			
UNIDEN CORP.			

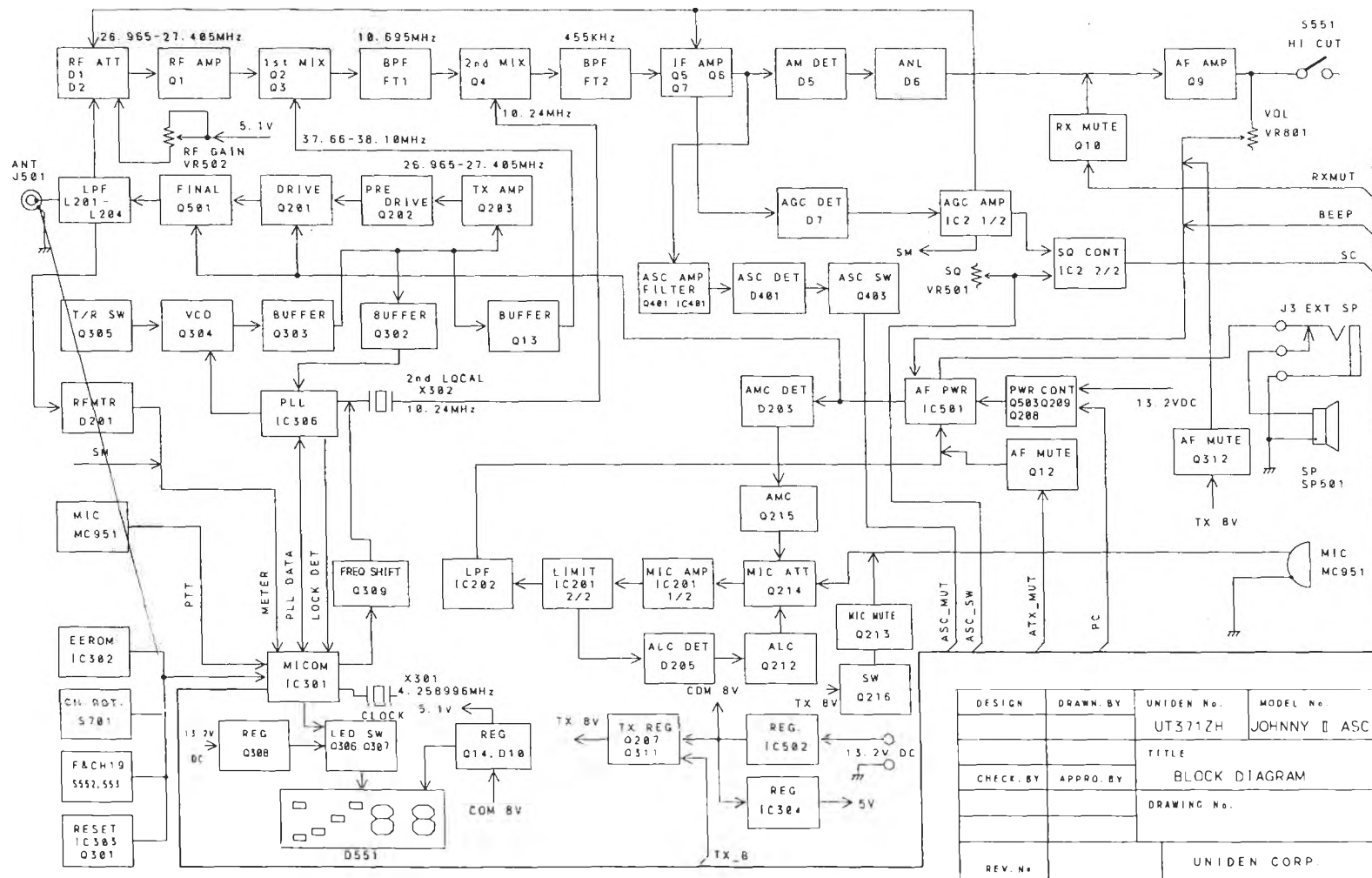

DESIGN	DRAWN BY	UNIDEN No.	MODEL No.
		UT371ZH	JOHNNY II ASC
TITLE			
BLOCK DIAGRAM			
DRAWING No.			
REV. No.			
UNIDEN CORP.			

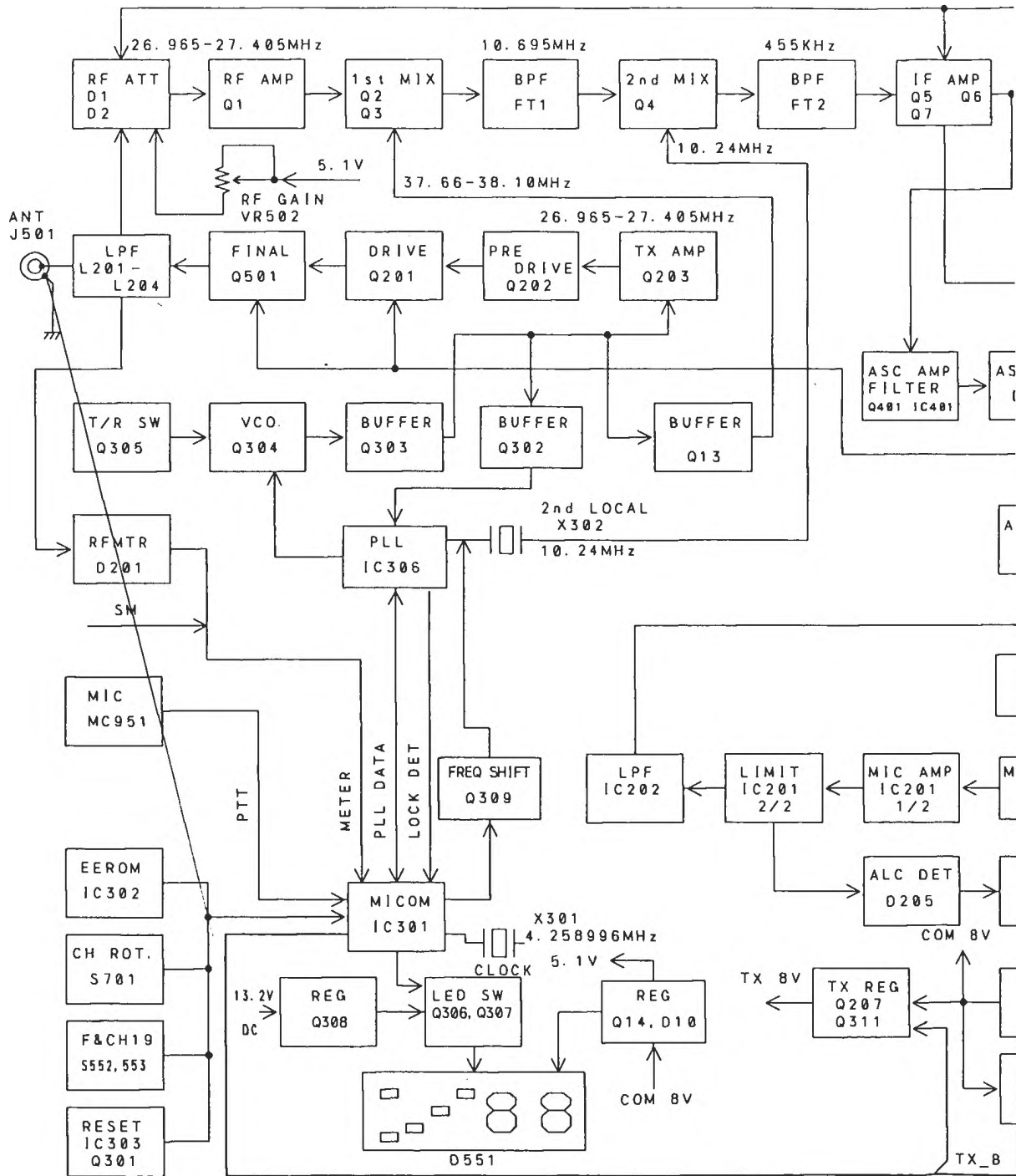

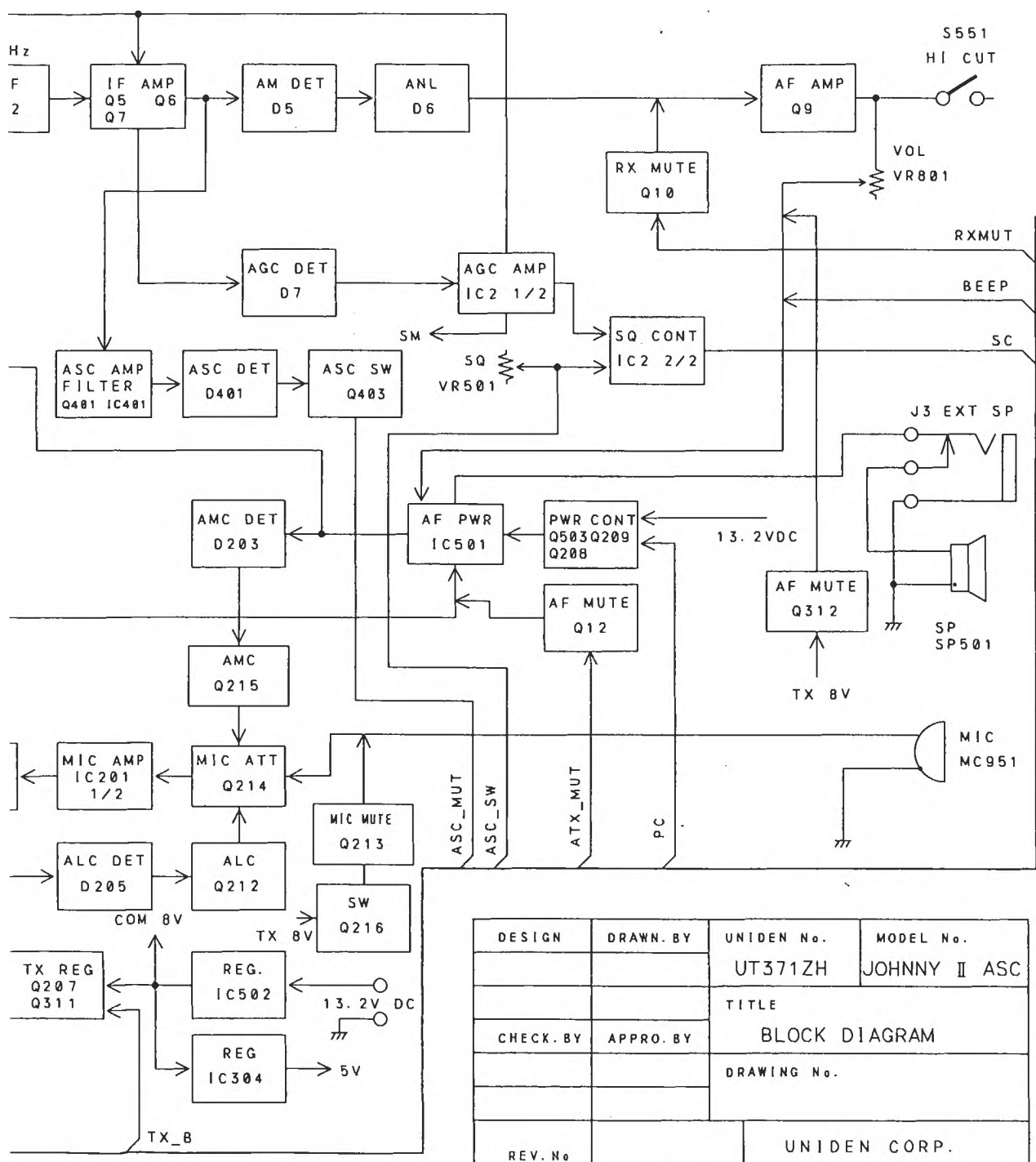

DESIGN	DRAWN. BY	UNIDEN No.	MODEL No.
		UT371ZH	JOHNNY II ASC
TITLE			
BLOCK DIAGRAM			
CHECK. BY	APPRO. BY	DRAWING No.	
REV. No.		UNIDEN CORP.	



PUT JAPANESE TAPE
UNDER J3

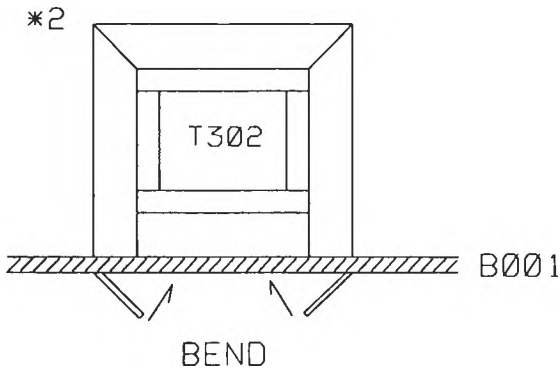
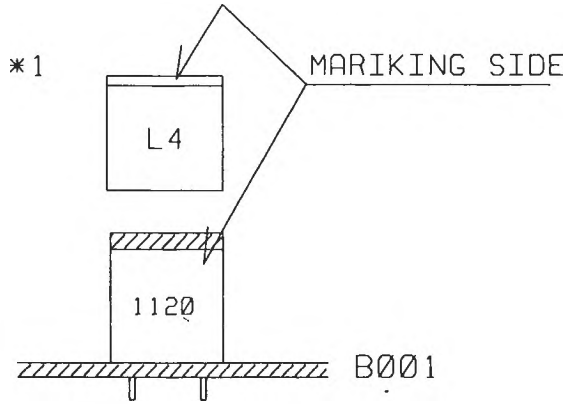

PUT IRRAX TUBE

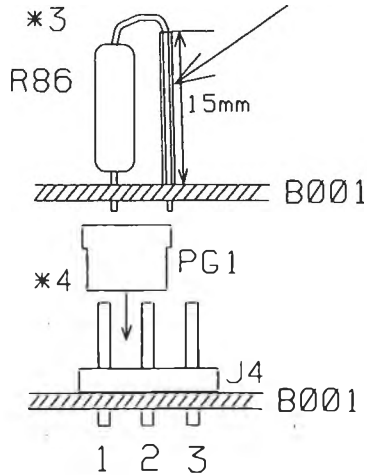

: YELLOW BOND LOCK(SC-121)

C004	4.7UF 50V	C-0156
C011	1UF 50V	C-0156
C021	0.47UF 50V	C-0156
C030	47UF 25V	C-0158
C031	47UF 25V	C-0158
C043	470UF 25V	C-0158
C044	47UF 25V	C-0158
C047	47UF 25V	C-0158
C065	47UF 25V	C-0158
C235	1000UF 16V	C-0158
C245	220UF 10V	C-0158
C253	47UF 25V	C-0158
C310	47UF 25V	C-0158
C312	470UF 10V	C-0158
C315	1000UF 25V	C-0158
C317	220UF 10V	C-0158
C320	220UF 10V	C-0158
C350	220UF 10V	C-0158
C368	22UF 50V	C-0158
CT301	CT-090 ECA-LA050M52 50PF	
D204	GD 1N4003-A2	
D304	SB340	
FT001	FL-055 10M07A2	
FT002	FL-052 LTS455HTW	
J003	JK-099 JH3501-0200	
J004	JK-1249 IMSA-0210B-1-0320	
L001	LB-1131 KS2484F	
L002	LB-1153 KS2485NC	
L003	LB-1227 KS2553N	
L004	LB-1120 KS2482AC	
L006	LB-1129 7PL4A151N	
L007	LB-1179 7MK4A033N	
L010	LD-007 BF04-3*5*1	
L011	LD-007 BF04-3*5*1	
L201	LE-475 AC1979	
L202	LE-408 AC1973	
L203	LE-408 AC1973	
L204	LE-475 AC1979	
L205	LC-255 MD146-08F42	
L206	LD-252 3A1737RH	
L207	LD-007 BF04-3*5*1	
L208	LE-535	
L209	LD-007 BF04-3*5*1	
L210	LZ-041 0.33UH	
L211	LD-007 BF04-3*5*1	
L301	LD-252 3A1737RH	
L302	LD-252 3A1737RH	
L360	LB-1226 KY1107R	
L361	LB-1226 KY1107R	
PG001	PG-185 IMSA-0215H-T	
Q201	OB-792 2SC2314F	
Q202	OB-301 2SC941TM-0	
Q209	OB-867 2SC3243-T11-E	
Q308	OB-867 2SC3243-T11-E	
R060	100K 1/4W	
R086	4.7 3WS	
R218	02 1WS	
R219	02 1WS	
R220	100 1WS	
R335	10K 1/6W	
R338	10K 1/6W	
R340	10K 1/6W	

ESE TAPE

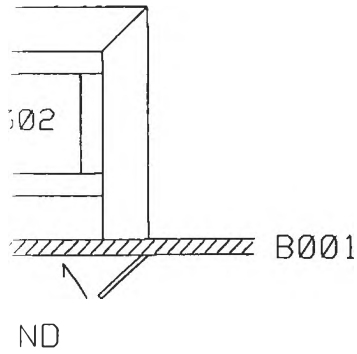
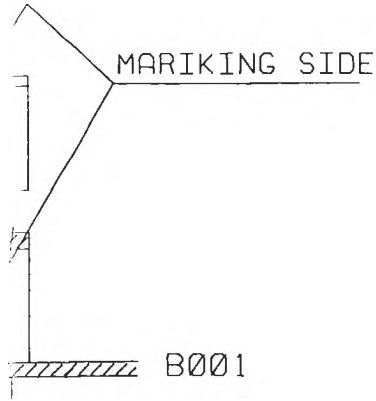

BRAX TUBE

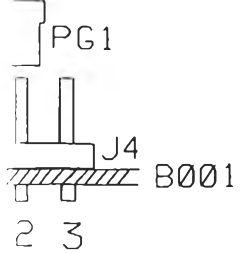
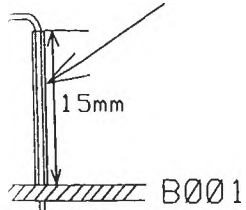

OND LOCK(SC-121)

C004	4.7UF 50V	C-0156
C011	1UF 50V	C-0156
C021	0.47UF 50V	C-0156
C030	47UF 25V	C-0156
C031	47UF 25V	C-0156
C043	470UF 25V	C-0156
C044	47UF 25V	C-0156
C047	47UF 25V	C-0156
C065	47UF 25V	C-0156
C235	1000UF 16V	C-0156
C245	220UF 10V	C-0156
C253	47UF 25V	C-0156
C310	47UF 25V	C-0156
C312	470UF 10V	C-0156
C315	1000UF 25V	C-0156
C317	220UF 10V	C-0156
C320	220UF 10V	C-0156
C350	220UF 10V	C-0156
C366	22UF 50V	C-0156
CT301	CT-090 ECA-LA050HS2	50PF
D204	GD 1N4003-A2	
D304	SB340	
FT001	FL-055 10M07A2	
FT002	FL-852 LTS455HTV	
J003	JX-899 JH3501-0200	
J004	JK-1249 IMSA-9210B-1-0320	
L001	LB-1131 KS24B4F	
L002	LB-1153 KS24B5NC	
L003	LB-1227 KS2553N	
L004	LB-1120 KS24B2AC	
L006	LB-1129 7PL4A151N	
L007	LB-1179 7MK4A033N	
L010	LD-087 BF04-3*5*1	
L011	LD-087 BF04-3*5*1	
L201	LE-475 AC1979	
L202	LE-486 AC1973	
L203	LE-486 AC1973	
L204	LE-475 AC1979	
L205	LC-255 MD146-08F42	
L206	LD-252 3A1737RH	
L207	LD-087 BF04-3*5*1	
L208	LE-535	
L209	LD-087 BF04-3*5*1	
L210	LZ-041 0.33UH	
L211	LD-087 BF04-3*5*1	
L301	LD-252 3A1737RH	
L302	LD-252 3A1737RH	
L360	LB-1226 KY1107R	
L361	LB-1226 KY1107R	
PG001	PG-185 IMSA-9215H-T	
Q201	QB-792 2SC2314F	
Q202	QB-301 2SC9411M-0	
Q209	QB-867 2SC3243-T11-E	
Q308	QB-867 2SC3243-T11-E	
R060	100K 1/4W	
R086	4.7 3WS	
R218	82 1WS	
R219	82 1WS	
R220	100 1WS	
R335	10K 1/6W	
R338	10K 1/6W	
R340	10K 1/6W	

R378	10K 1/4W
R395	56 1WS
R398	10K 1/4W
T301	TF-157
T302	TF-215
TP001	TP-122 1820-01-PP1
W001	UL1007 #24 10-140-3 GRAY
W002	UL1007 #24 10-140-3 WHT
W003	UL1571 #26 5-30-5 WHT
X301	QX-796 4.258996MHZ
X302	QX-074 10.240MHZ

NOTES:

1. RESISTANCE VALUES ARE SHOWN IN OHMS UNLESS OTHERWISE NOTED. (K-KILO OHM, M-MEG OHM)
2. CAPACITANCE VALUES ARE INDICATED IN MICRO FARADS UNLESS OTHERWISE NOTED.

DESIGN. BY	DRAWN. BY	UNIDEN NO.	MODEL NO.
		UT371ZH	J.DHNNY II ASC
		TITLE MAIN PCB	
CHECK. BY	APPRO. BY	PARTS ASS'Y TOP VIEW	
		DRAWING NO.	
REV. NO.		UNIDEN CORP.	

B001: PA-435AA 1/4 (TOP VIEW)

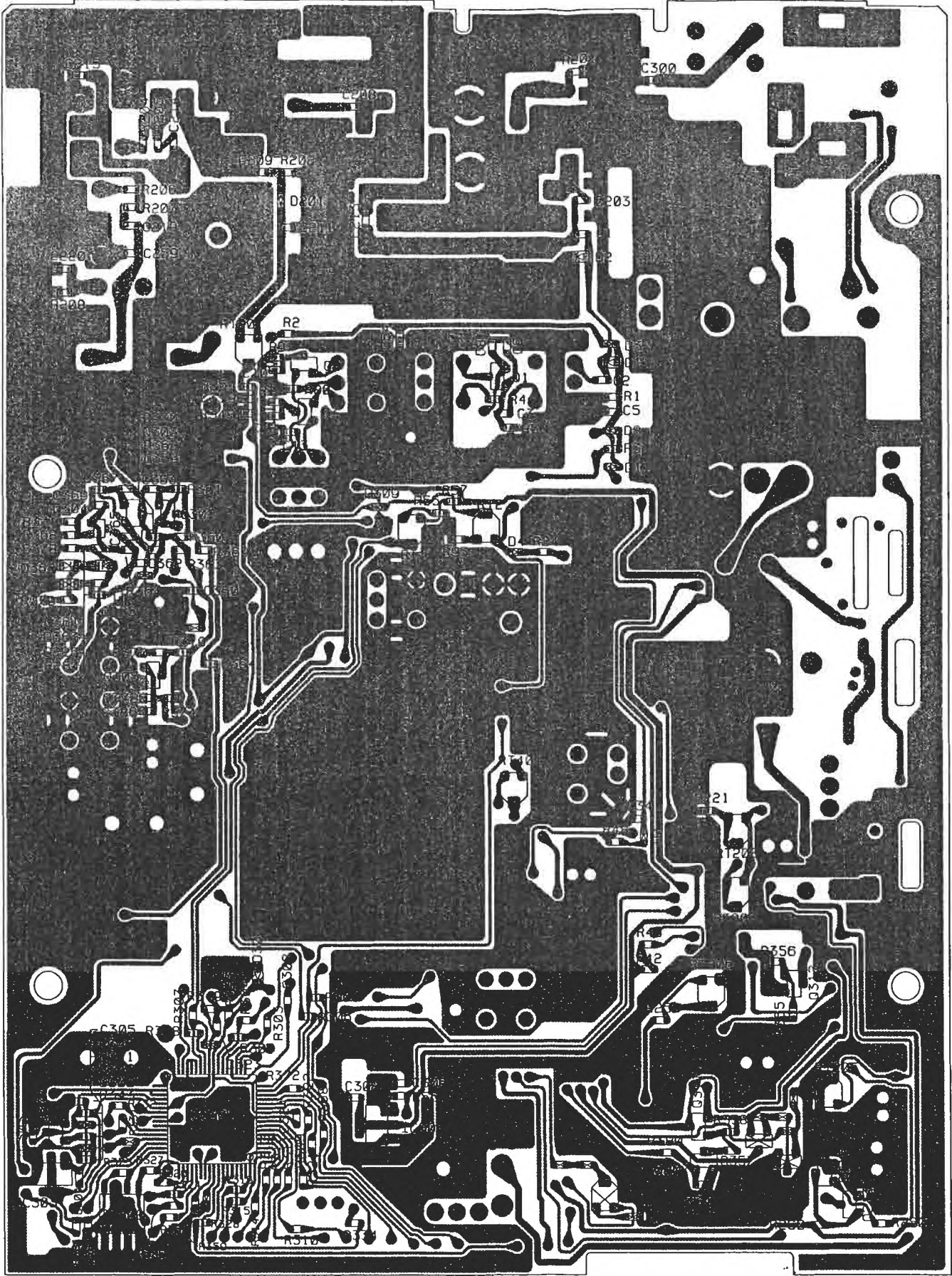

REVISIONS	REV. CODE	△	△	△	△	△	△	△	△	△	△	△	△	△	△	△	△	△
	DATE																	
	LOT#/RN#																	
	REVISED BY																	
CHECKED BY																		

DESIGN. BY	DRAWN. BY	UNIDEN NO.	M
		UT371ZH	J
CHECK. BY	APPRO. BY	TITLE	DRAWING NO.
		MAIN PCB CHIP LAYOUT	
REV. NO.			UNIDEN

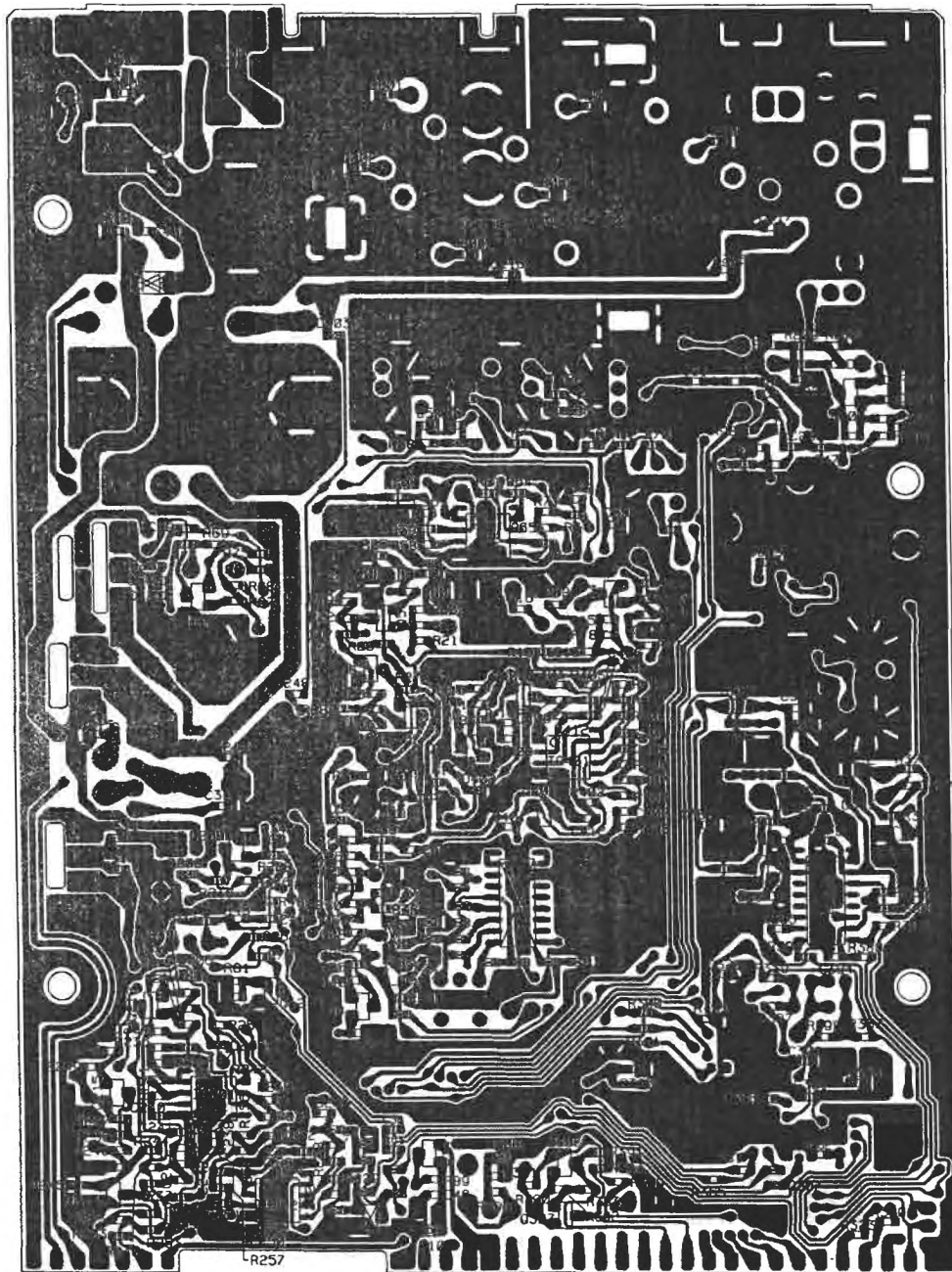

REV. NO.	REV. CODE																					
	DATE																					
	LOT#/RN#																					
	REVISED BY																					
	CHECKED BY																					

DESIGN BY	DRAWN BY	UNIDEN NO.	MODEL NO.
		U13712H	JOHNNY X ASC
CHECK BY	APPROD BY	TITLE MAIN PCB 1/2 CHIP LAYOUT BOTTOM VIEW	
		DRAWING NO.	
REV. NO.		UNIDEN CORP.	

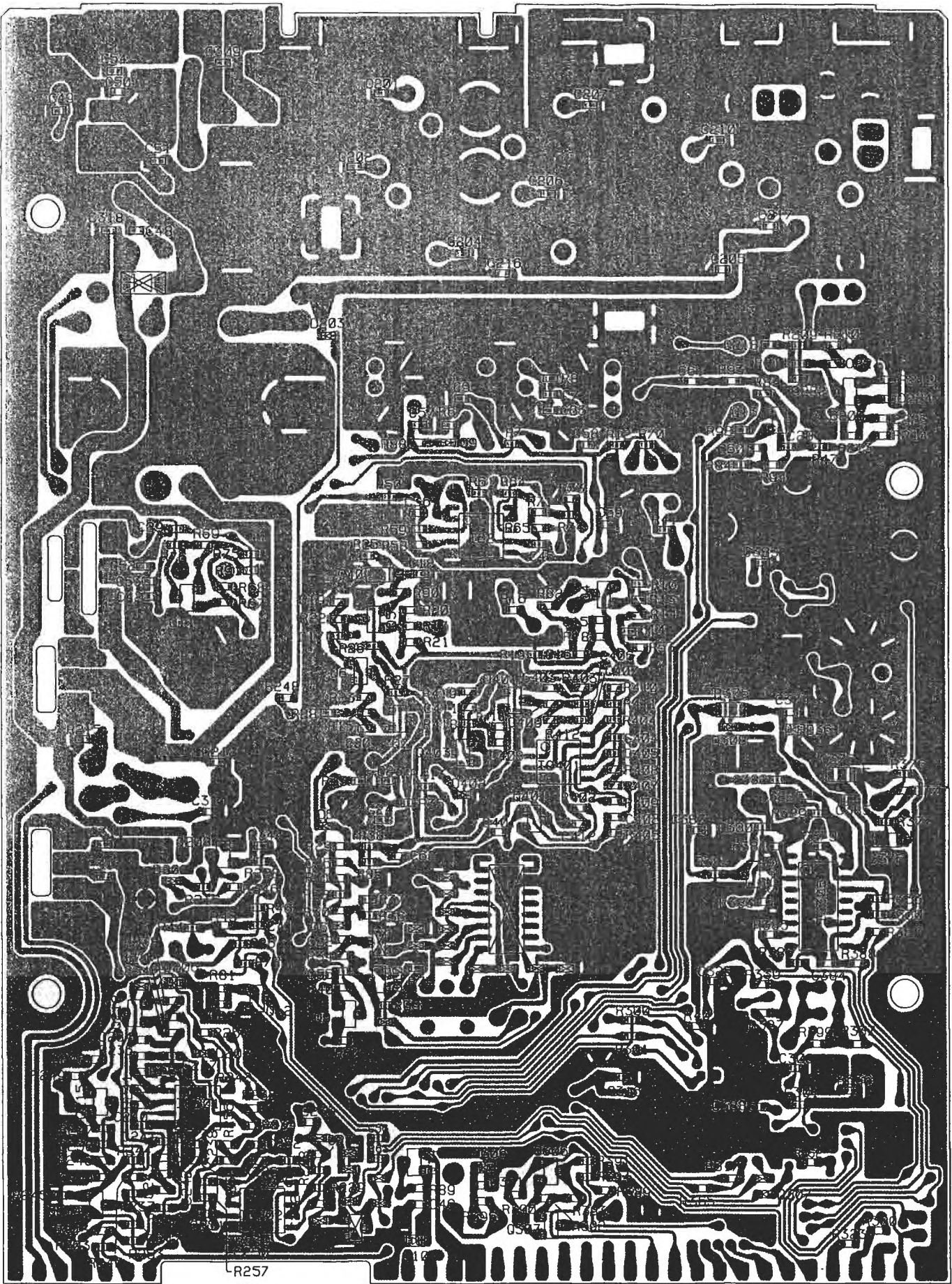

REVISIONS	REV. CODE	△	△	△	△	△	△	△	△	△	△	△	△	△	△	△	△	△	△	△	△
	DATE																				
	LOT#/RN#																				
	REVISED BY																				
	CHECKED BY																				

DESIGN. BY	DRAWN. BY	UNIDEN NO.
		UT371ZH
CHECK. BY	APPRO. BY	TITLE MAIN P.
		CHIP LAYOUT
		DRAWING NO.
REV. NO.		UNI