

SOMMERKAMP[®]

CITIZENS BAND
TRANSCEIVER

MODEL
TS-5612

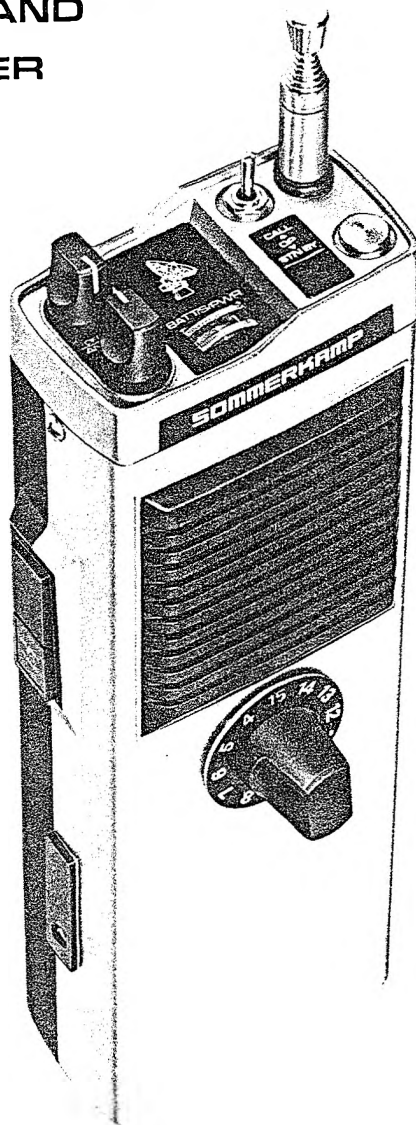

INSTRUCTION MANUAL

CONTROL LOCATIONS:

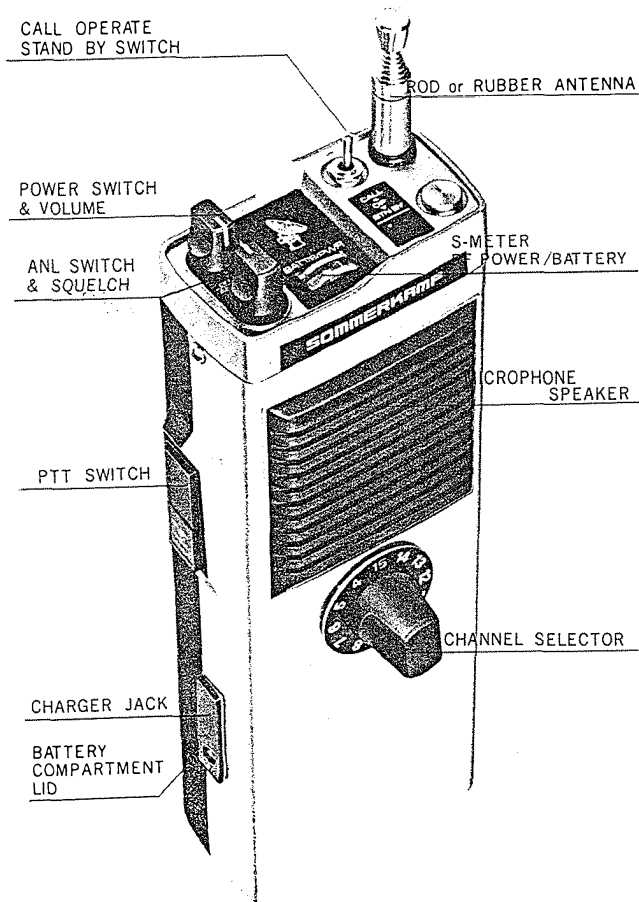

PACKING LIST:

Beside this manual, the carton shall contain the following items:

- 1 Transceiver TS-5612
- 1 Carrying case with shoulder strap
- 1 Earphone case with earphone
- 2 pcs. dummy batteries inside the batterie case

GENERAL :

Your SOMMERKAMP TS-5612 transceiver has been designed for continuous heavy duty portable application. The transceiver is designed to operate with internal dry cells or rechargeable nickel-cadmium batteries such as N500AA set with the 12360 charger.

To prevent excessive battery drain, this transceiver has a stand-by switch in combination with the operate and call switch, which by a timing circuit and a switching transistor switches the receiver on for 2 seconds and off for 10 seconds. This device extends the battery life 6 times longer compared with continuous squelched stand-by operation. It is necessary, however, for a calling station to call by minimum 10-15 seconds before reception and contact is possible.

RECEIVER SECTION:

The receiver section is designed to receive amplitude modulated (AM/A3) signals in the 26.965 to 27.275MHz. (11 meter) citizens band. The unique combination of low noise Field Effect Transistors(FET), single conversion, a combination of mechanical ceramic, and L/C filters, fully automatic noise limiter and a hifi quality speaker amplifier will give you exceptional reception quality in this fine piece of equipment.

In addition, the above combination of the latest technology provides you with a sensitivity and unwanted signal rejection and noise suppression available previously only in space and military communication equipment.

The power supply of the receiver section is stabilized by an extreme sharp cut-off Zener diode controlled series stabilizer to obtain the high sensitivity and unwanted signal rejection. The fully automatic series gate noise limiter, which virtually cuts off the audio output during ignition noise pulses, is defeatable to make even the weakest signal audible which otherwise would be cut off by the threshold level of the ANL switching diode.

The high squelch sensitivity is achieved by using a separate squelch detector and switching circuit with a carefully balanced hysteresis. The transformerless hifi quality audio power amplifier will drive any load between 32 ohms and indefinite such as internal speaker/microphone combination or external speaker/microphone or headset combinations having the above impedances.

The meter indicates the field strength during reception of a signal. and without signal the battery condition.

TRANSMITTER & MODULATOR SECTION:

The transmitter section is designed for continuous heavy duty transmission of amplitude modulated (AM/A3) signals on any of the 6 channels in the 26.965 to 27.275MHz. (11 meter) citizens band.

The modulator consists of an active audio filter type speech processor, integrated pre-and power amplifier and modulation transformer. This gives you the lowest possible modulation distortion and up to 100% modulation. The input is designed for the 32 ohm speaker/microphone combination.

RECEIVE/TRANSMIT SWITCHING:

The receive/transmit switching is done by a single pole, single throw micro switch with a life time of about 5 million operations and a combination of NPN and PNP switching transistors which also function in the receive mode as series voltage stabilizer. For remote switching, a parallel contact is provided at the accessory jack.

METER:

The combination meter provides you with the following functions:

During receive mode.....it indicates the incoming signal strength, and without incoming signals the battery condition.

During transmit mode...it indicates the output power.

STAND-BY:

The stand-by feature is incorporated to reduce battery drain during monitoring of a channel if no continuous communication is necessary.

POWER SUPPLY:

This transceiver is designed to operate with a nominal 12V DC power supply such as the internal dry cells or nickel-cadmium rechargeable batteries.

UNPACKING AND CHECKOUT

Unpack the carton carefully and check for exterior damages.

Check that the volume control is in the OFF position, the squelch control in the ANL-OFF position and the standby-operate-call switch in OPERATE position.

press the dent of the battery compartment lid and pull it out toward the bottom.

Lift out the battery holder and insert 8 dry cells into the holder as indicated. \oplus to \oplus , \ominus to \ominus pole. Leave the 2 dummy batteries in the holder as they are. If you use rechargeable batteries, insert 10 pieces of them in the same manner as above but remove the dummy batteries.

Snap the battery holder onto the snap connector provided and reinsert the holder into the compartment.

Replace the compartment lid by inserting it straight from the bottom up until it snaps in rightly.

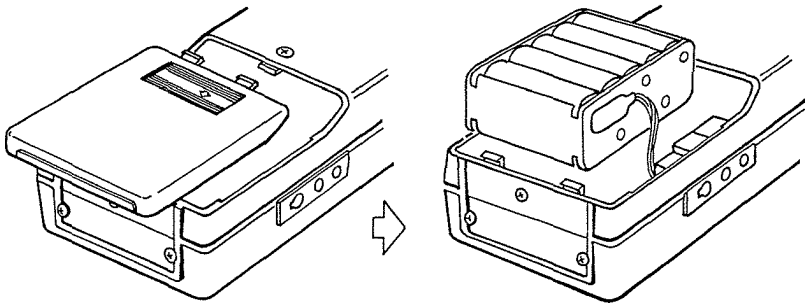

Then switch the transceiver ON by rotating the volume control clockwise and check that the meter needle moves into the red field. If the meter needle does not move, switch OFF immediately and check if the standby-operate-call switch is in the OPERATE position. If this is the case, open the battery compartment to remove the battery holder to ensure that the batteries are correctly inserted.

Now turn the volume control until noise is heard from the speaker. Then extend the rod antenna to the full length.

Switch the standby-operate-call switch to STANDBY. The noise from the speaker shall cease and the meter needle shall move to the black field. Within 10-15 seconds, the noise from the speaker shall be heard again and the meter needle moves to the red field. Wait for this cycle to repeat itself several times, then switch to OPERATE.

Rotate the channel switch step by step from channel 4 to 15 and check that some noise and/or signal is heard on each channel.

Push the push-to-talk (PTT) switch and observe the meter needle. It shall move into the red field. Now whistle into the speaker/microphone. The needle shall move a little. The same applies while pressing and releasing the call switch between operate and call.

Repeat this check on each channel. This completes the checkout.

OPERATION

Extend the rod antenna completely and switch the transceiver ON by rotating the volume control clockwise.

Rotate the channel switch to the desired channel.

Adjust the volume control to a comfortable level.

Press the PTT switch and talk with a normal voice into the speaker/microphone from a distance of 5-10 cm. After completing your transmission, release the PTT switch, and the transceiver is ready for reception. Always remember that your opposite party cannot hear you while he is transmitting.

Adjust the squelch control so that the background noise just disappears during non-transmitting periods of your opposite party.

For stand-by operation, switch the STANDBY-OPERATE-CALL switch to STANDBY. Remember that the transceiver is 10 seconds OFF and 2 seconds ON and that your opposite party has to call for at least 10-15 seconds so that you can receive the call. Call either by voice or by the built-in tone call for this duration.

To answer the received call, switch to OPERATE, push the PTT switch and talk into the speaker/microphone.

To receive weak signals, turn the squelch control fully counter-clockwise so that the ANL is switched OFF.

To switch the transceiver OFF, turn the volume control fully counter-clockwise until a click is heard and the meter needle moves into the black field.

Important:

If you will not operate the transceiver for a long time, remove the batteries from the equipment so that they will not corrode and damage the transceiver.

ACCESSORIES

To install N500AA rechargeable nickel-cadmium batteries, follow the instructions under the Chapter UNPACKING AND CHECKOUT of this manual.

Charge the N500AA nickel-cadmium batteries by plugging the 1236 charger into the charger jack. Charge for 14 hours. It is not possible to operate the transceiver during charging.

PRINTED CIRCUIT BOARD PARTS LAYOUT

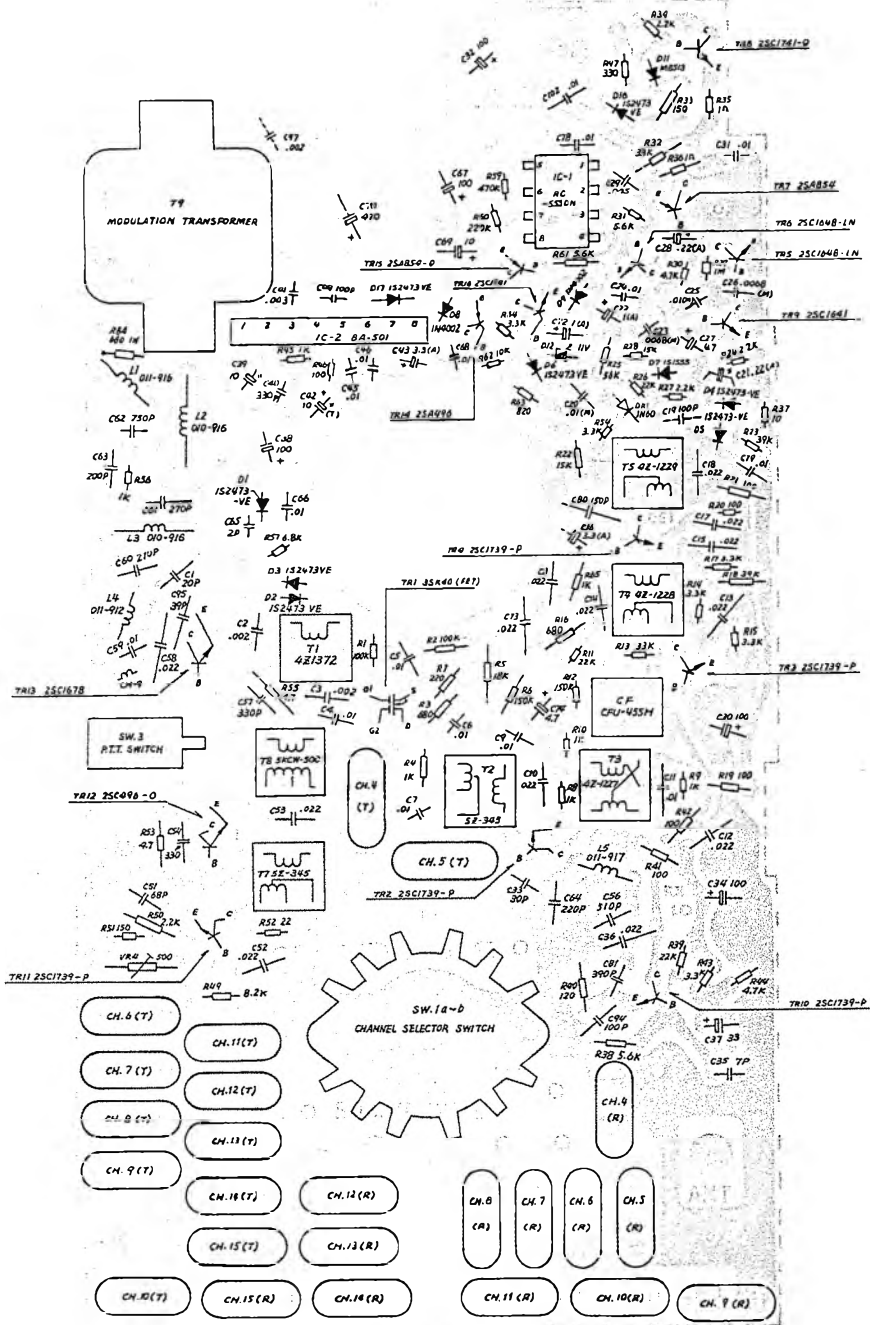

BLOCK DIAGRAM

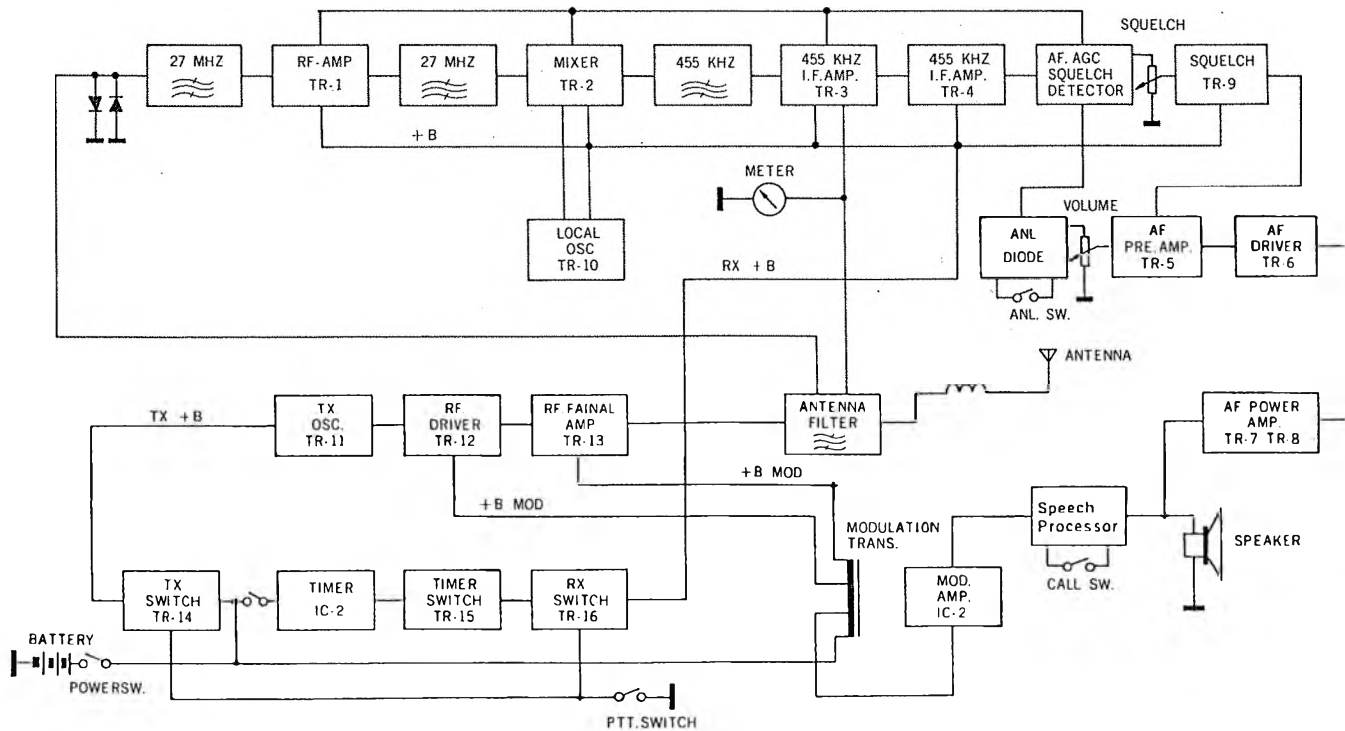

WIRING LAYOUT BOTTOM VIEW

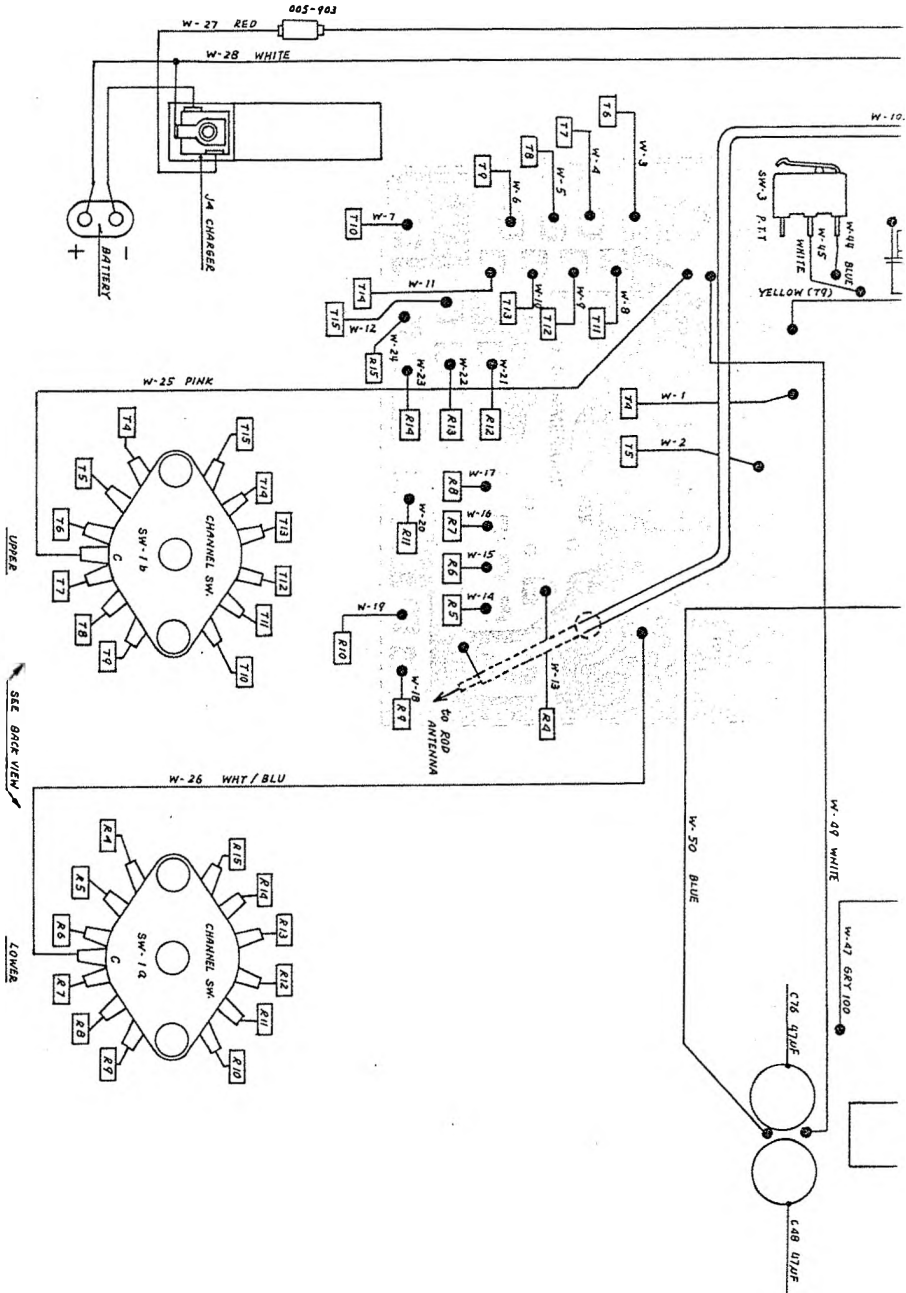

CIRCUIT DIAGRAM

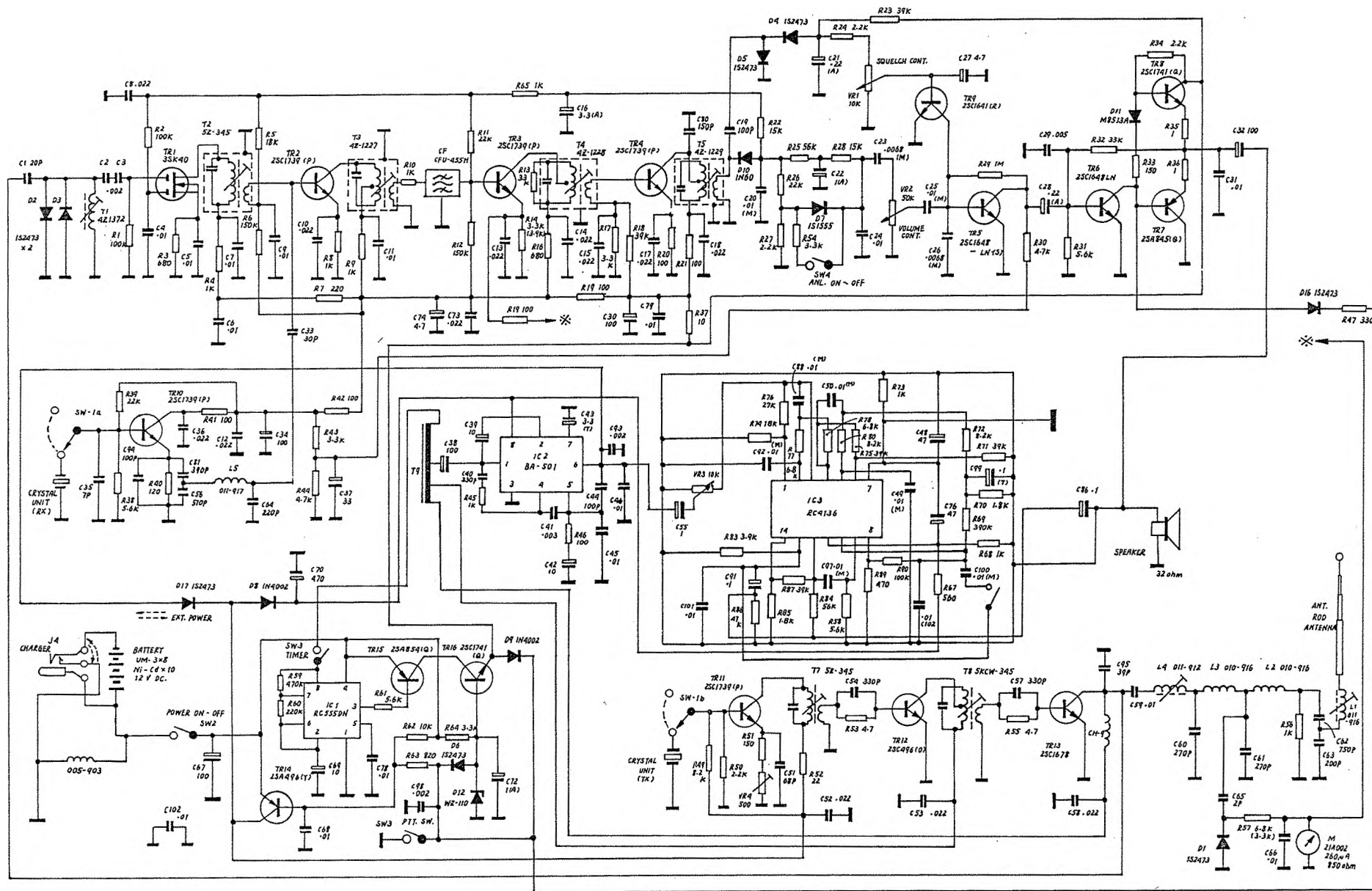

ELECTROLYTIC CONDENSER

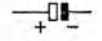

WIRING LAYOUT BOTTOM VIEW

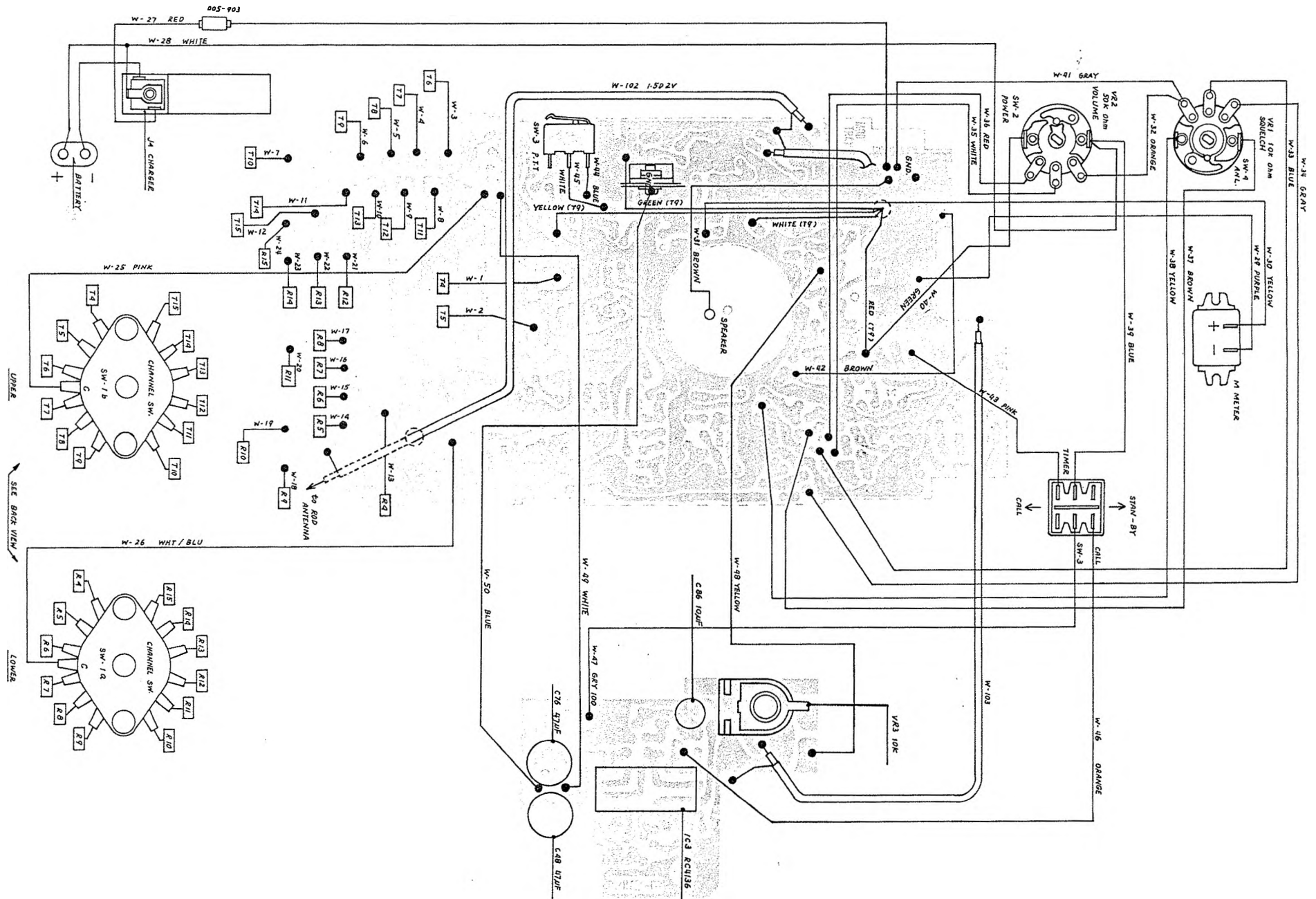

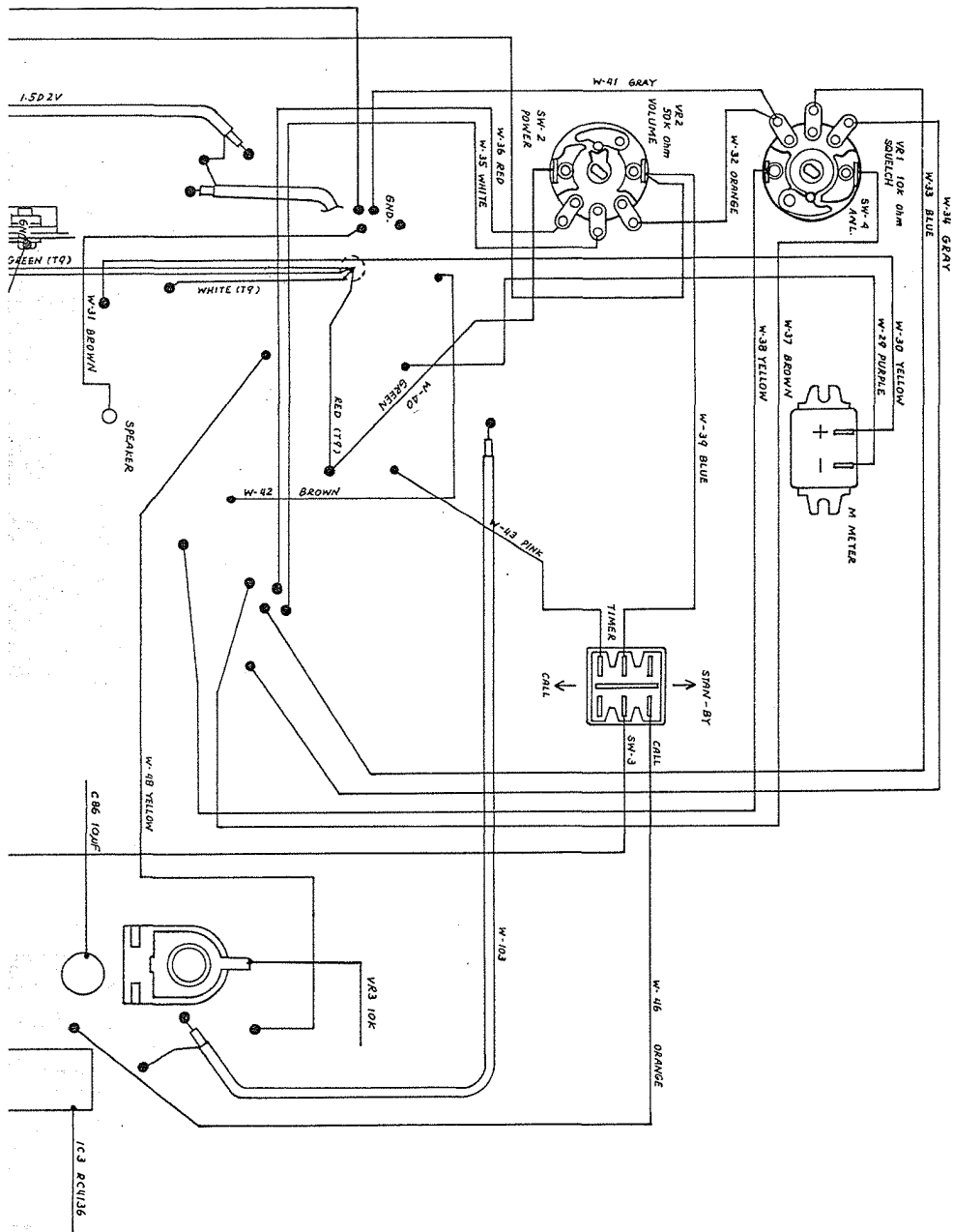

PARTS LIST for TS-5612

DESIGNATION	PARTS NAME	PARTS NO.
MP-5601	Cabinet Front	492023
MP-5602	Cabinet Top	493037
MP-5603	Cabinet Back	492021
MP-5604	Cabinet Cover for BATT.	493039
MP-5605	Speaker Grill	493038
MP-5606	Bushing for Rod Antenna	494205
MP-5607	Knob for VOL/SQU Control	494199
MP-5608	P. T. T. Button Assembly	494200
MP-5609	Cabinet Bottom Plate	494198
MP-5610	Mounting Bracket for Rod Antenna	494202
MP-5612	Frame for P. C. B.	494196
MP-5613	Heatsink for 2SC1237	494215
MP-5614	Mounting Bracket for Microswitch	494216
MP-209	Mounting Bracket for Speaker	474009
MP-5615	Brand plate	494212
MP-5616	P. T. T. Button Plate	494211
MP-5617	VOL/SQU Plate	494208
MP-5617	Toggle Switch plate	494210
MP-5619	Back plate	494213
MP-5621	Channel Indicator plate	494231
MP-5622	Battery Case Holder	494207
MP-5623	Supporter for P. C. B.	494227
MP-5624	Speaker Net	494229
MP-5625	Rod Antenna Cover	494219
MP-5626	Knob for Channel Selector	494226
PP-5601	Carrying Case	CC-5632
PP-5612IM	Instruction Manual	IM-5606
PP-5612G	Gift Box	GB-5606
TRI	FET	3SK40
TR7, 15	Transistor	2SA854
TR14	Transistor	2SA496-Y
TR8, 16	Transistor	2SC1741-Q
TR5, 6	Transistor	2SC1648-LN-S
TR9	Transistor	2SC1641-R
TR2,3,4,10,11	Transistor	2SC1739
TR13	Transistor	2SC1678
TR12	Transistor	2SC496-0

PARTS LIST for TS-5612

DESIGNATION	PARTS NAME	PARTS NO.
IC-1	IC.	RC555DM
IC-2	IC.	BA-501
D1,2,3,4,5,6,17	Silicon Diode	1S2473-VE
D8,9	Silicon Diode	1N4002
D11	Varistor Diode	M8513A
D12	Zener Diode	WZ11V
D10	Germanium Diode	1N60
D7	Silicon Diode	1S1555
MF	Ceramic Filter	CFU-455H
VR2	Variable Resistor (Volume) 50K ohm	13-50KAS
VR1	Variable Resistor (Squelch) 10K ohm	13-10BBS
SW3	Micro Switch (P. T. T.)	SS-5
SW5	Toggle Switch	8A2051
SW1	Rotary Switch	M26S
EP-301	Crystal Socket	XS-1P
SP	Speaker 57 $\frac{m}{m}$ 32 ohm IMP.	57P-15-7
J4	Tri Jack	C-G-0112-02
T9	Modulation Transformer	T-5606
M	Meter	21A002
ANT	Rod Antenna	A-32
EP-500	Battery Case UM-3 \times 10	BC3-10
L1	ANT. Loading Coil	011-916
L2	TX Final π Matching Coil	010-916
L3	TX Final π Matching Coil	010-916
L4	TX Final Tuning Coil	011-912
L5	RX OSC. Filfer Coil	011-917
T1	RX Tuning Coil	4Z-1372
T2,7	RX RF OUT Tuning Coil	5Z-345
T3	IFT. 455 KHZ (YELLOW)	4Z-1227
T4	IFT. 455 KHZ (WHITE)	4Z-1228
T5	IFT. 455 KHZ (BLACK)	4Z-1229
IC-3	IC.	RC-4136
VR-3	Semi Variable Resistor 10K ohm	SVR010KS3

SPECIFICATIONS

GENERAL:

Dimensions	230 (h) × 78 (w) × 43.5 (d) mm
Weight	800 grams without batteries
Powersupply	8 penlight dry cells (12 volts) or 10 penlight rechargeable nickel-cadmium batteries (12.5 volts)
Cabinet	Aluminium die cast front and high impact ABS back
Channels	12 channels
Controls	volume; squelch; ANL; standby; operate; call; channel
Microphone	internal microphone/speaker combination
Semiconductors	2 integrated circuits; 16 transistors; 2 FET; 17 diodes
Special Features	Electronic T/R switching; 12 channels; standby battery saver; switchable automatic noise limiter; S, power and battery meter; active audio filter type speech processor.

RECEIVER:

Frequency range	27.005 to 27.135 MHz
Sensitivity	0.5 μ V for 10dB S + N/N and 100 mW output at 30% 1KHz modulation
Selectivity	6KHz at -6 dB
Adjacent channel rej	better than 50 dB average
Audio output at 10%	250 mW
Spurious response	more than 50 dB down
Intermodulation	more than 50 dB down
Crossmodulation	more than 50 dB down
Squelch sensitivity	less than 0.1 μ V
Noise limiter	automatic series gate
Power consumption	Receive mode (standby) 8 mA Receive mode (full audio) 60 mA

TRANSMITTER:

Frequency range	27.005 to 27.135
Modulation capability	100 %
Modulation distortion	less than 5% at 95% modulation
Frequency tolerance	1,200 Hz at -20 to +50 degrees C

T5	IFT. 455 KHZ (I
IC-3	IC.

ELECTRONIC SAS

CH-6903 LUGAND, P. O. BOX 176
SWITZERLAND
TEL. 91 688543 TELEX: 79314