

MOTHER BOARD F3056101A

IF UNIT F305710

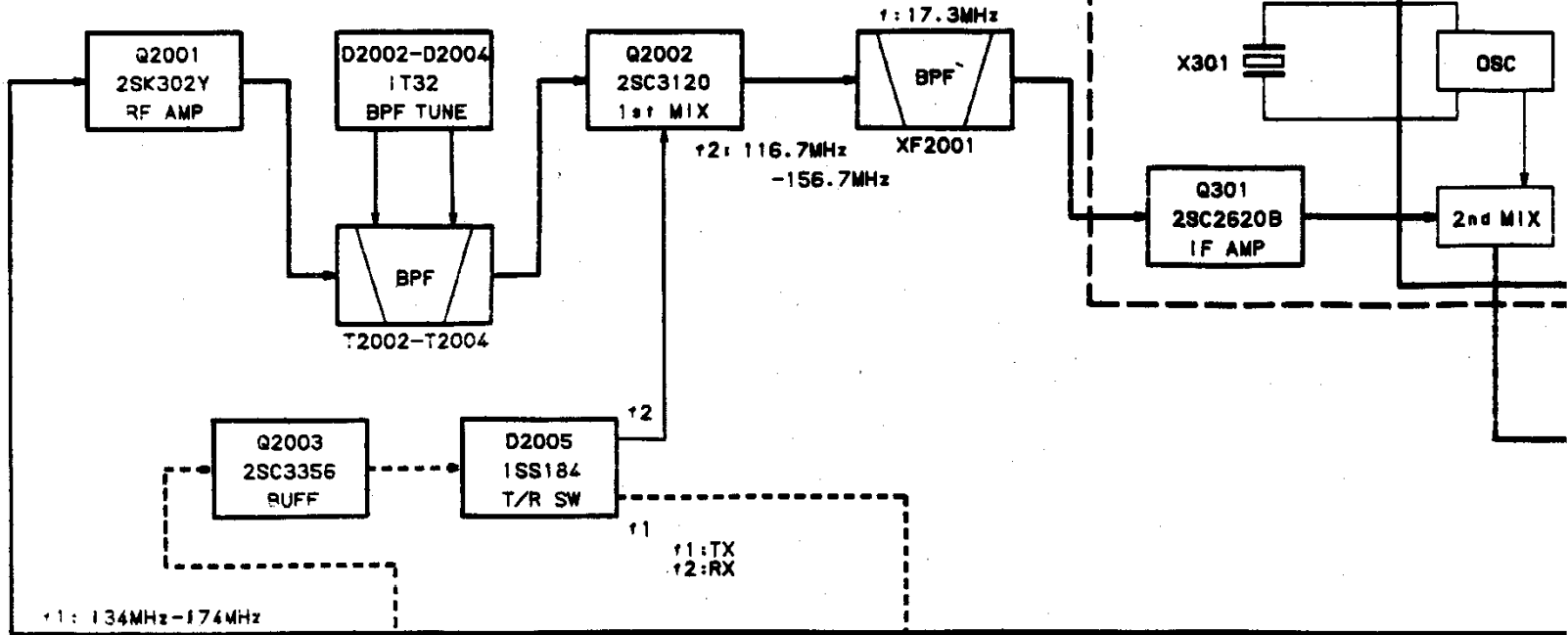

VCO BUF UNIT F3057104

VCO OSC UNIT F3057103

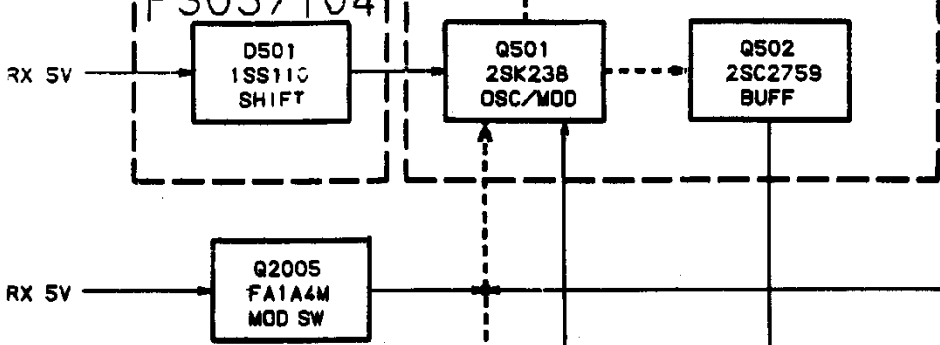

Atype: M57796MA
Ctype: M57798H

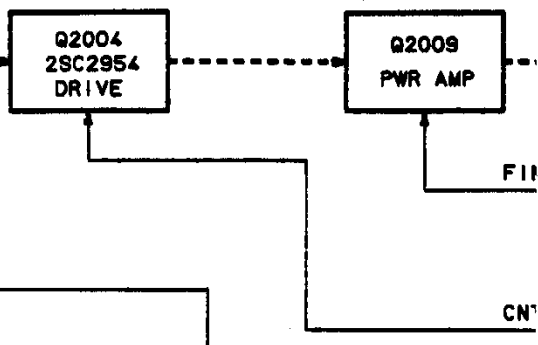

LIM AMP/LPF

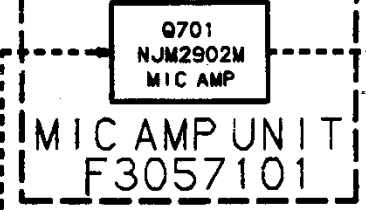

Q401 MC12017 PRESCALER

PLL UNIT F3057106A

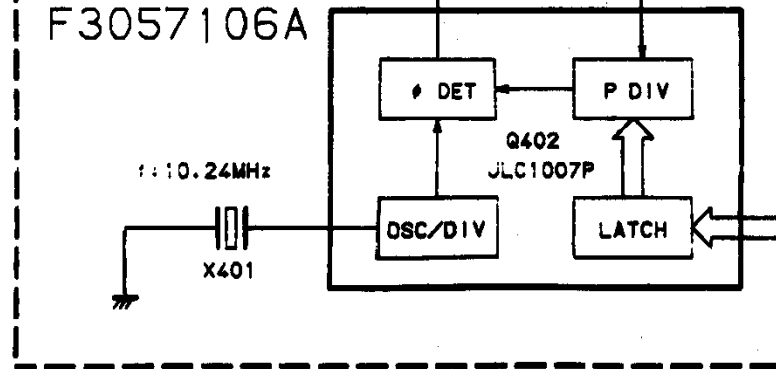

CNTL UNIT F305610

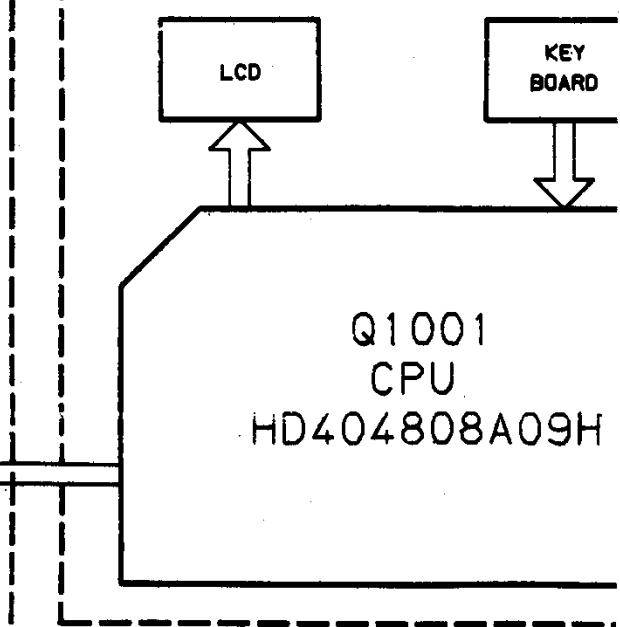

FTH-2008 BLOCK DIAGRAM

2A

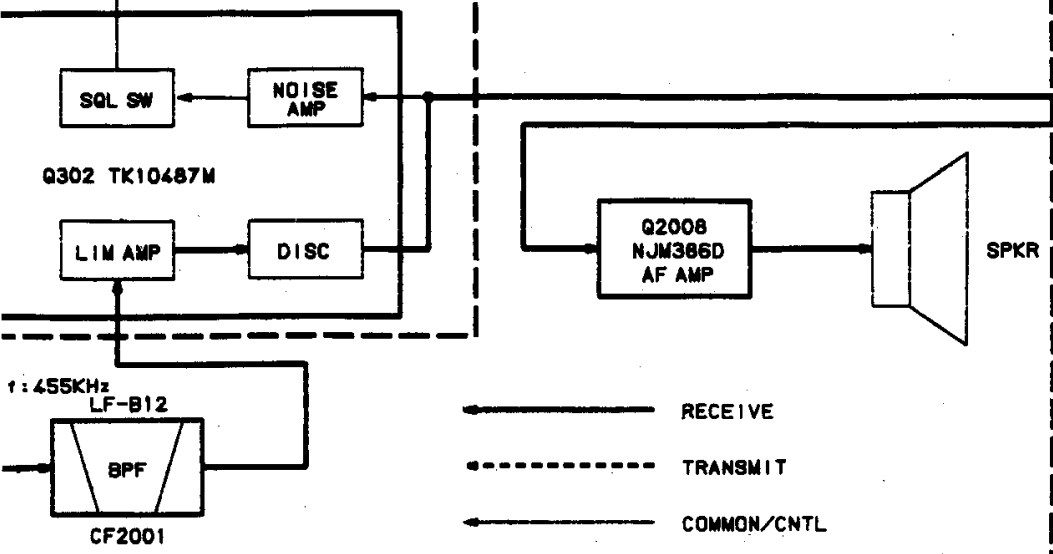

← RECEIVE
 - - - TRANSMIT
 ← COMMON/CNTL

Q901, Q905 2SB799ML
 Q902, Q903, Q904 2SC2712GR

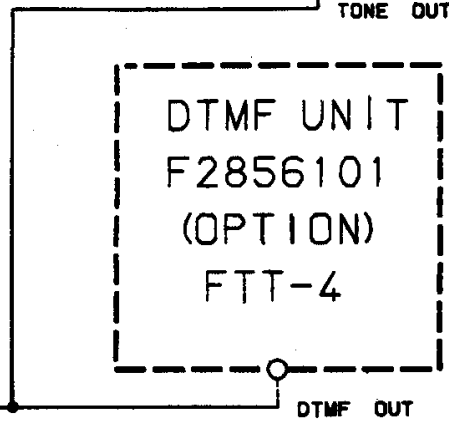
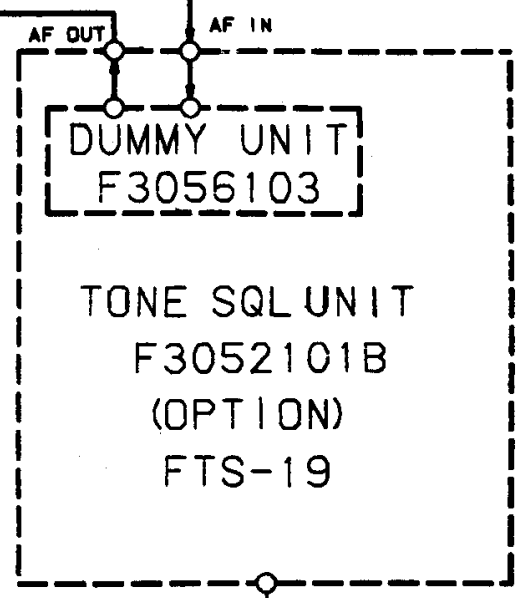
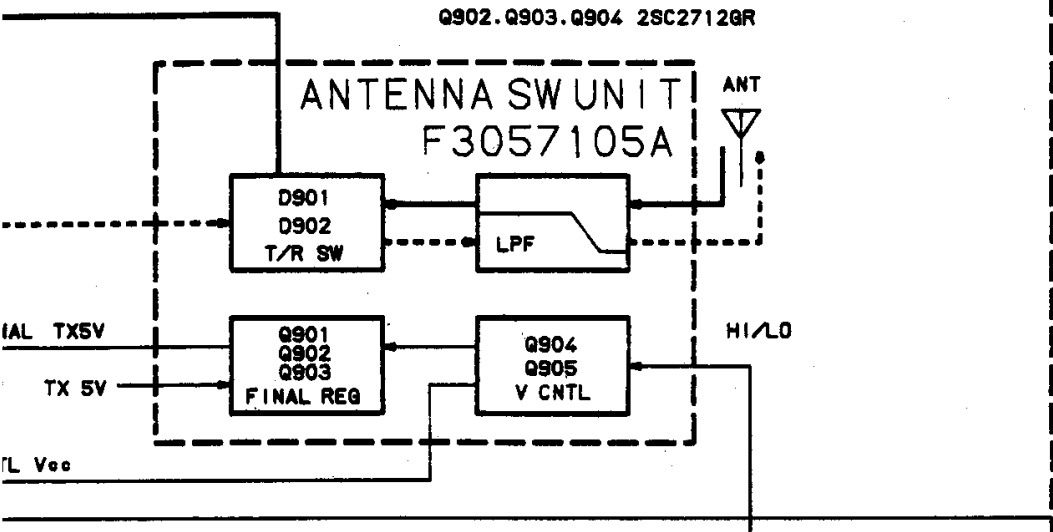

2A

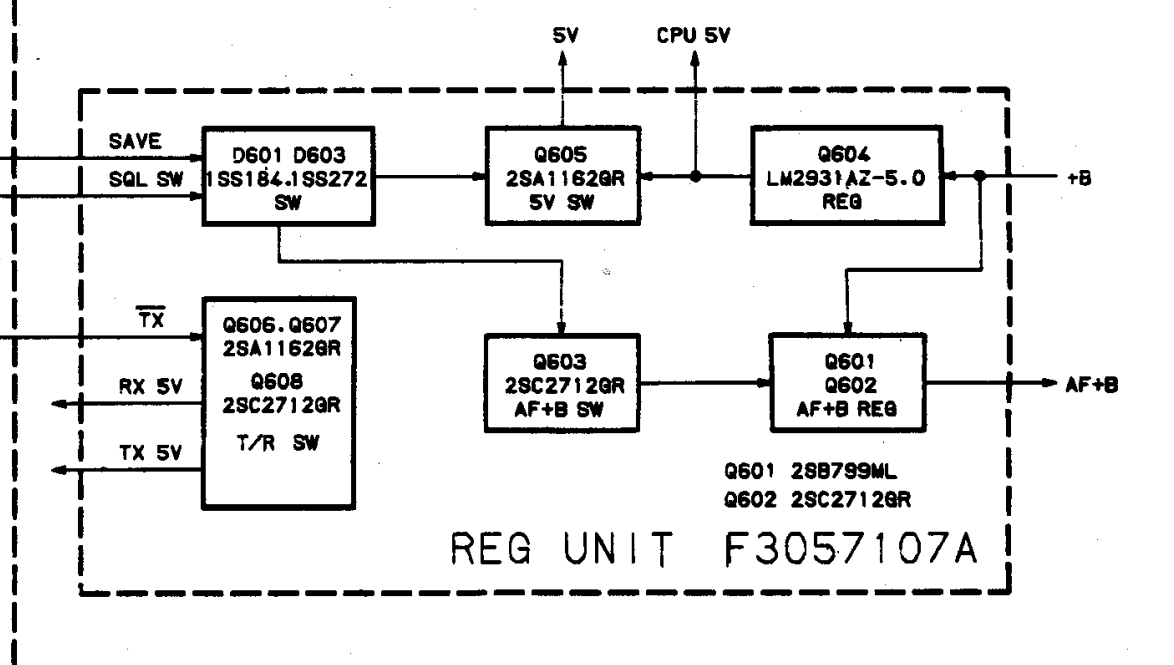
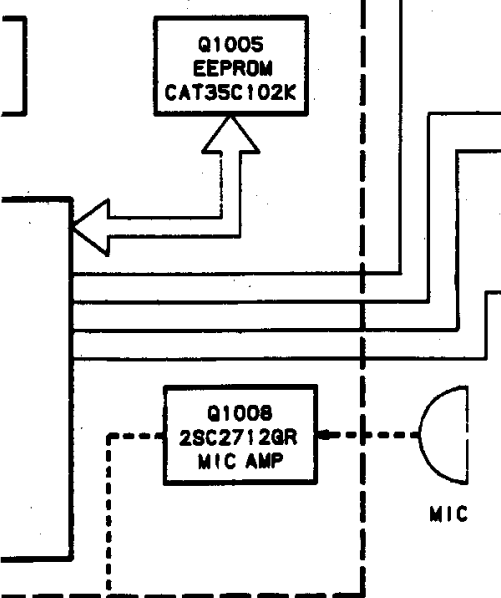

Q601 2SB799ML
 Q602 2SC2712GR

REG UNIT F3057107A

F3056101B Printed Circuit Board

CA0022001 PCB W/Components
CA0022002 PCB W/Components

TYP A

TYP C

C 2001	K22170203	CHIP CAP.	GRM40CK020C50PT	2pF	50V	CK	TYP C
C 2001	K22170204	CHIP CAP.	GRM40CJ030C50PT	3pF	50V	CJ	TYP A
C 2002	K22144802	CHIP CAP.	GRM39B103M25PT	0.01uF	25V	B	
C 2003	K22174809	CHIP CAP.	GRM39B102M50PT	0.001uF	50V	B	
C 2004	K22170223	CHIP CAP.	GRM40CH330J50PT	33pF	50V	CH	TYP A
C 2004	K22170221	CHIP CAP.	GRM40CH270J50PT	27pF	50V	CH	TYP C
C 2005	K22170203	CHIP CAP.	GRM40CK020C50PT	2pF	50V	CK	
C 2006	K22170202	CHIP CAP.	GRM40CK010C50PT	1pF	50V	CK	TYP C
C 2006	K22170204	CHIP CAP.	GRM40CJ030C50PT	3pF	50V	CJ	TYP A
C 2008	K22170223	CHIP CAP.	GRM40CH330J50PT	33pF	50V	CH	TYP A
C 2008	K22170221	CHIP CAP.	GRM40CH270J50PT	27pF	50V	CH	TYP C
C 2009	K22170223	CHIP CAP.	GRM40CH330J50PT	33pF	50V	CH	TYP A
C 2009	K22170221	CHIP CAP.	GRM40CH270J50PT	27pF	50V	CH	TYP C
C 2010	K22170223	CHIP CAP.	GRM40CH330J50PT	33pF	50V	CH	TYP A
C 2010	K22170221	CHIP CAP.	GRM40CH270J50PT	27pF	50V	CH	TYP C
C 2011	K22174809	CHIP CAP.	GRM39B102M50PT	0.001uF	50V	B	
C 2013	K22174809	CHIP CAP.	GRM39B102M50PT	0.001uF	50V	B	
C 2014	K22170202	CHIP CAP.	GRM40CK010C50PT	1pF	50V	CK	
C 2015	K22170229	CHIP CAP.	GRM40CH560J50PT	56pF	50V	CH	
C 2017	K22170817	CHIP CAP.	GRM40B103M50PT	0.01uF	50V	B	
C 2018	K22170817	CHIP CAP.	GRM40B103M50PT	0.01uF	50V	B	
C 2019	K22170208	CHIP CAP.	GRM40CH070D50PT	7pF	50V	CH	
C 2022	K22120805	CHIP CAP.	GRM40R683M16PT	0.068uF	16V	R	
C 2023	K40089023	AL. ELECTRO. CAP.	RC2-6V470MS	47uF	6.3V		
C 2024	K40129059	AL. ELECTRO. CAP.	RC3-16V4R7MS	4.7uF	16V		
C 2025	K22174809	CHIP CAP.	GRM39B102M50PT	0.001uF	50V	B	
C 2026	K40109026	AL. ELECTRO. CAP.	10VB-100(M)CC	100uF	10V		
C 2027	K22120805	CHIP CAP.	GRM40R683M16PT	0.068uF	16V	R	
C 2028	K70107476	TANTALUM CAP.	DN1A470M1S	47uF	10V		
C 2029	K22174809	CHIP CAP.	GRM39B102M50PT	0.001uF	50V	B	
C 2030	K40129052	AL. ELECTRO. CAP.	RC2-16V100MS	10uF	16V		
C 2031	K40129038	AL. ELECTRO. CAP.	RC2-16V101MS	100uF	16V		
C 2032	K22174809	CHIP CAP.	GRM39B102M50PT	0.001uF	50V	B	
C 2033	K78100002	CHIP TA CAP.	F951A335MSAAF1Q2	3.3uF	10V		
C 2034	K22141808	CHIP CAP.	GRM42-6B473M25PT	0.047uF	25V	B	
C 2035	K22170221	CHIP CAP.	GRM40CH270J50PT	27pF	50V	CH	
C 2036	K22170805	CHIP CAP.	GRM40B102M50PT	0.001uF	50V	B	
C 2037	K22144802	CHIP CAP.	GRM39B103M25PT	0.01uF	25V	B	
C 2038	K22144802	CHIP CAP.	GRM39B103M25PT	0.01uF	25V	B	
C 2039	K22170215	CHIP CAP.	GRM40CH150J50PT	15pF	50V	CH	TYP C
C 2039	K22170221	CHIP CAP.	GRM40CH270J50PT	27pF	50V	CH	TYP A
C 2040	K22170211	CHIP CAP.	GRM40CH100D50PT	10pF	50V	CH	TYP A
C 2041	K22174235	CHIP CAP.	GRM39CH101J50PT	100pF	50V	CH	
C 2043	K22170805	CHIP CAP.	GRM40B102M50PT	0.001uF	50V	B	
C 2044	K22170805	CHIP CAP.	GRM40B102M50PT	0.001uF	50V	B	
C 2045	K22174809	CHIP CAP.	GRM39B102M50PT	0.001uF	50V	B	
C 2046	K22174809	CHIP CAP.	GRM39B102M50PT	0.001uF	50V	B	
C 2047	K22174809	CHIP CAP.	GRM39B102M50PT	0.001uF	50V	B	
C 2048	K22174809	CHIP CAP.	GRM39B102M50PT	0.001uF	50V	B	
C 2049	K22120805	CHIP CAP.	GRM40R683M16PT	0.068uF	16V	R	
C 2050	K22144802	CHIP CAP.	GRM39B103M25PT	0.01uF	25V	B	
C 2051	K22170203	CHIP CAP.	GRM40CK020C50PT	2pF	50V	CK	TYP A
C 2053	K22170817	CHIP CAP.	GRM40B103M50PT	0.01uF	50V	B	
C 2054	K78080015	CHIP TA CAP.	F950J226MWCFA1	22uF	6.3V		

C 2055	K22170225	CHIP CAP.	GRM40CH390J50PT	39pF	50V	CH
CF2001	H3900280	CERAMIC FILTER	LF-B12			
D 2001	G2070003	DIODE	1SS226 TE85R			
D 2002	G2070035	DIODE	1T32-T8			
D 2003	G2070035	DIODE	1T32-T8			
D 2004	G2070035	DIODE	1T32-T8			
D 2005	G2070009	DIODE	1SS184 TE85R			
D 2006	G2070003	DIODE	1SS226 TE85R			
D 2007	G2070026	DIODE	1SS196 TE85R			
J 2001	P0090599	CONNECTOR	IL-Y-5P-S15T2-EF			
J 2002	P0090601	CONNECTOR	IL-Y-14P-S15T2-EF			
J 2003	P0090598	CONNECTOR	IL-Y-4P-S15T2-EF			
J 2004	P0090609	CONNECTOR	SB20-02WS			
L 2002	L1190342	M. RFC	LAL02KRR22M	0.22uH		
L 2003	L1020671	RFC				TYP A
L 2003	L0020744	COIL				TYP C
L 2004	L1190342	M. RFC	LAL02KRR22M	0.22uH		TYP C
Q 2001	G3803027Y	FET	2SK302-Y TE85R			
Q 2002	G3331207	TRANSISTOR	2SC3120 TE85R			
Q 2003	G3333567	TRANSISTOR	2SC3356-T2B			
Q 2004	G3329547	TRANSISTOR	2SC2954-T2			
Q 2005	G3070001	TRANSISTOR	FA1A4M-T2B			
Q 2007	G3327127G	TRANSISTOR	2SC2712GR TE85R			
Q 2008	G1090920	IC	NJM386D			
Q 2009	G1090768	IC	M57796H			TYP C
Q 2009	G1090732	IC	M57796MA			TYP A
R 2001	J24185101	CHIP RES.	RMC1/16 101JATP	100	1/16W	
R 2002	J24205560	CHIP RES.	RMC1/10T 560J	56	1/10W	
R 2003	J24185105	CHIP RES.	RMC1/16 105JATP	1M	1/16W	
R 2004	J24185104	CHIP RES.	RMC1/16 104JATP	100K	1/16W	
R 2005	J24185104	CHIP RES.	RMC1/16 104JATP	100K	1/16W	
R 2006	J24185474	CHIP RES.	RMC1/16 474JATP	470K	1/16W	
R 2007	J24185564	CHIP RES.	RMC1/16 564JATP	560K	1/16W	
R 2008	J24185152	CHIP RES.	RMC1/16 152JATP	1.5K	1/16W	TYP C
R 2008	J24185471	CHIP RES.	RMC1/16 471JATP	470	1/16W	TYP A
R 2009	J24185222	CHIP RES.	RMC1/16 222JATP	2.2K	1/16W	
R 2010	J24185101	CHIP RES.	RMC1/16 101JATP	100	1/16W	
R 2011	J24205473	CHIP RES.	RMC1/10T 473J	47K	1/10W	
R 2014	J24205104	CHIP RES.	RMC1/10T 104J	100K	1/10W	
R 2016	J24185470	CHIP RES.	RMC1/16 470JATP	47	1/16W	
R 2017	J24205473	CHIP RES.	RMC1/10T 473J	47K	1/10W	
R 2018	J24185223	CHIP RES.	RMC1/16 223JATP	22K	1/16W	
R 2019	J24205100	CHIP RES.	RMC1/10T 100J	10	1/10W	
R 2020	J24185333	CHIP RES.	RMC1/16 333JATP	33K	1/16W	TYP A
R 2020	J24185153	CHIP RES.	RMC1/16 153JATP	15K	1/16W	TYP C
R 2021	J24185221	CHIP RES.	RMC1/16 221JATP	220	1/16W	TYP A
R 2022	J24205331	CHIP RES.	RMC1/10T 331J	330	1/16W	
R 2023	J24185152	CHIP RES.	RMC1/16 152JATP	1.5K	1/16W	TYP C
R 2023	J24185332	CHIP RES.	RMC1/16 332JATP	3.3K	1/16W	TYP A
R 2024	J24205479	CHIP RES.	RMC1/10T 4R7J	4.7	1/10W	
R 2025	J24205150	CHIP RES.	RMC1/10T 150J	15	1/10W	
R 2026	J24205223	CHIP RES.	RMC1/10T 223J	22K	1/10W	
R 2027	J24185103	CHIP RES.	RMC1/16 103JATP	10K	1/16W	
R 2028	J24185000	CHIP RES.	RMC1/16 000JATP	0	1/16W	
R 2030	J24205000	CHIP RES.	RMC1/10T 000J	0	1/10W	

R 2031	J24185101	CHIP RES.	RMC1/16 101JATP	100	1/16W	
R 2032	J01225220	CARBON FILM RES.	RD16PJ220	22	1/6W	TYP C
T 2001	L0021416	COIL				
T 2002	L0021418	COIL				
T 2003	L0021418	COIL				
T 2004	L0021418	COIL				
T 2005	L0021947	COIL				
TP2001	Q5000016	TERMINAL	TP-E/MS-60124		TP-E	
VR2001	J50781203	POT.	EVN-D2AA03B 20KB		20KB	
VR2002	J60800166	POT.	RK0971110 20KA		20KA	
VR2004	J51778473	POT.	RH03AYAS4X 47K		47K	
VR2005	J51778473	POT.	RH03AYAS4X 47K		47K	
XF2001	H1102154	XTAL FILTER	17N15BU			
XF2002	H1102154	XTAL FILTER	17N15BU			

MOTHER BOARD UNIT(No.2***)

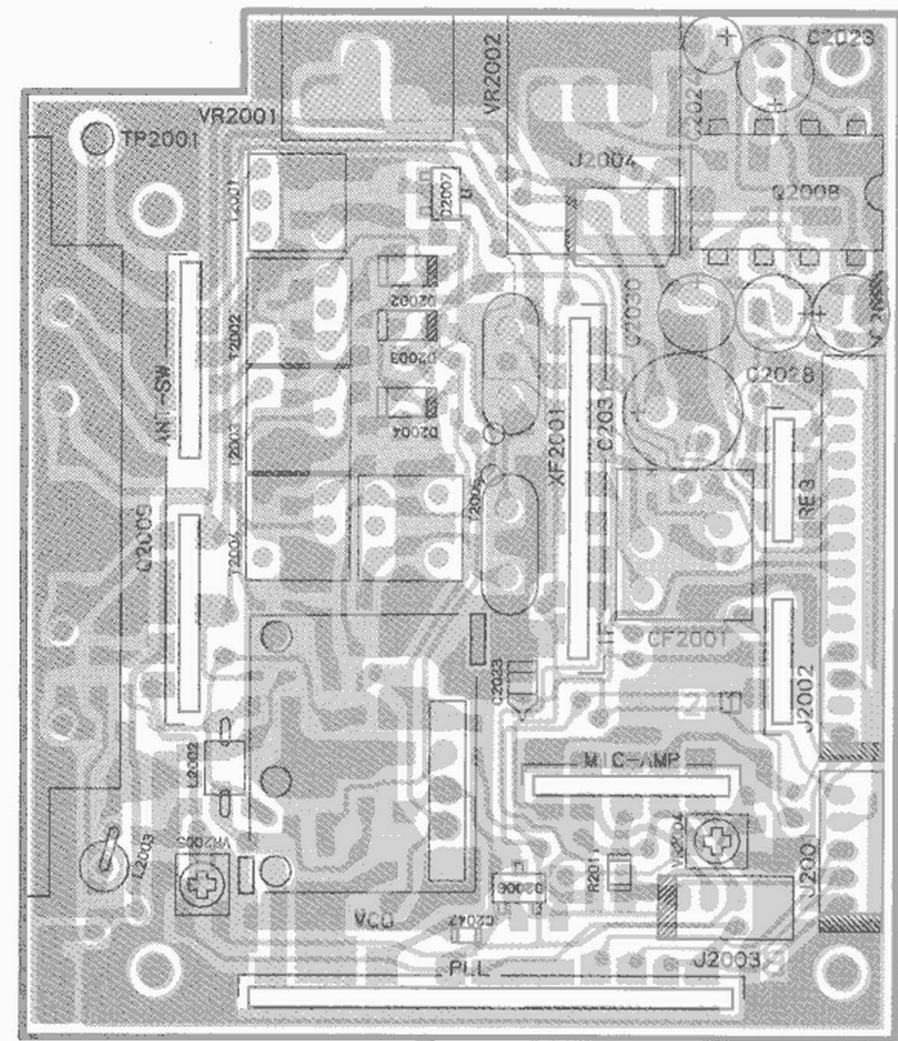

obverse view "component" side

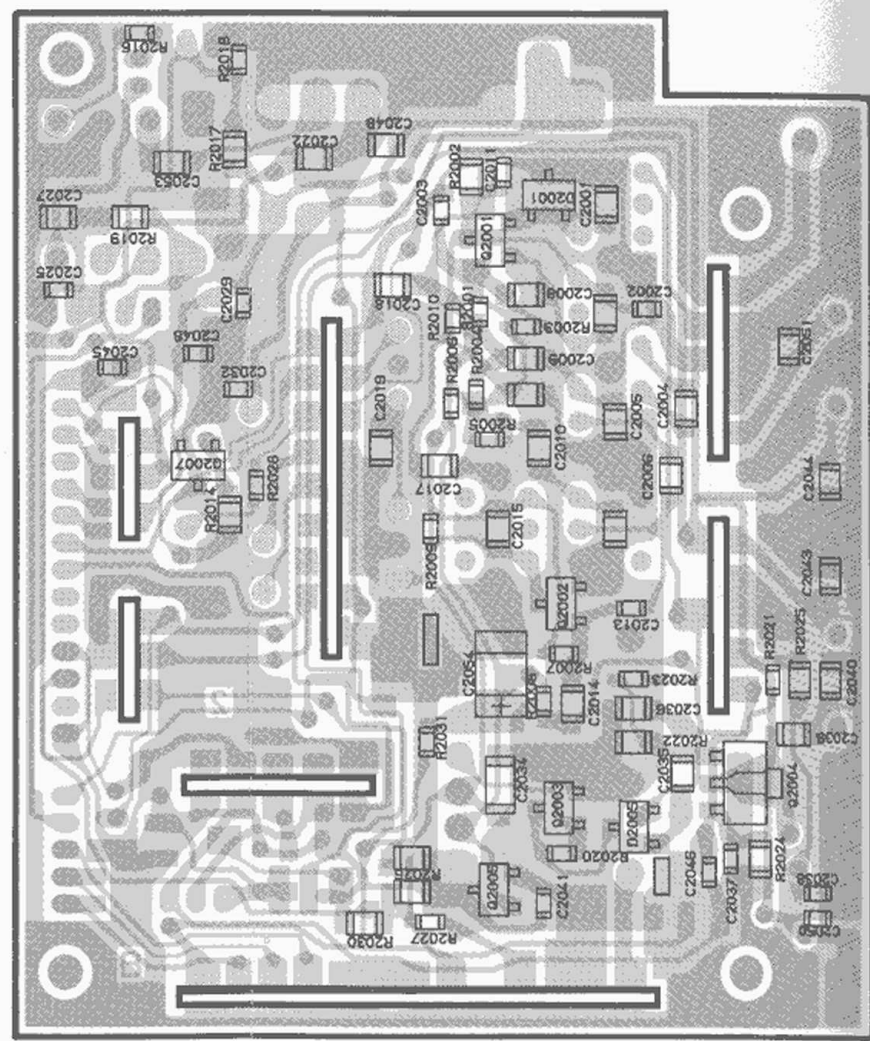

obverse view "chip-only" side

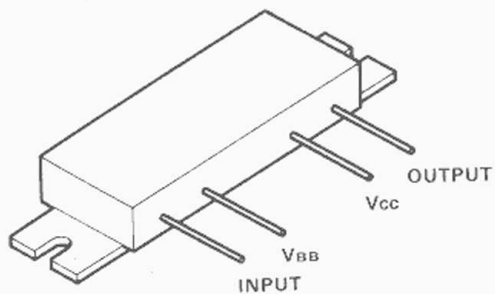

TYP A: M57796MA(Q2009)
TYP C: M57796H(Q2009)

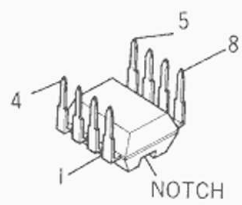

NJM386D(Q2008)

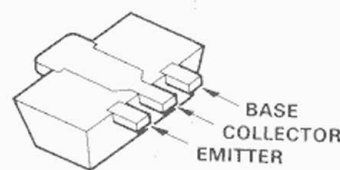

2SC2954(QK)(Q2004)

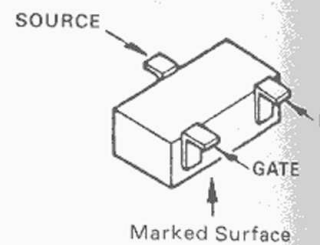

2SK302Y(TY)(Q2001)

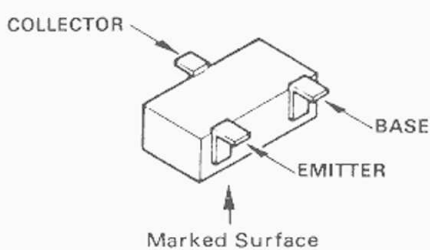

2SC2712GR(LG)(Q2007)
2SC3120(HB)(Q2002)
FA1A4M(L33)(Q2005)
2SC3356(R25)(Q2003)

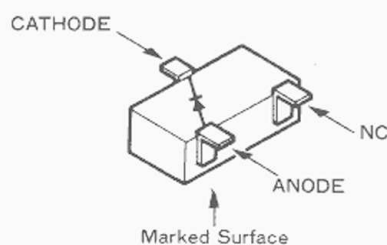

1SS196(G3)(D2007)

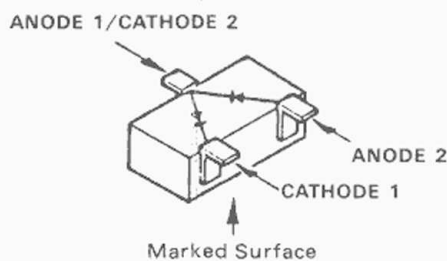

1SS226(C3)(D2001, D2006)

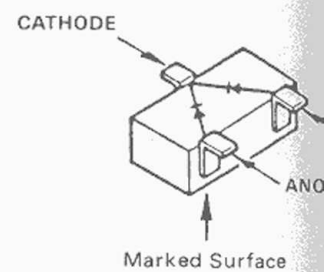

1SS184(B3)(D2005)

MOTHER-BOARD UNIT

F3056101A

RESISTOR VALUES ARE IN Ω , 1/16W;
CAPACITOR VALUES ARE IN μ F, 50V;
UNLESS OTHERWISE NOTED.

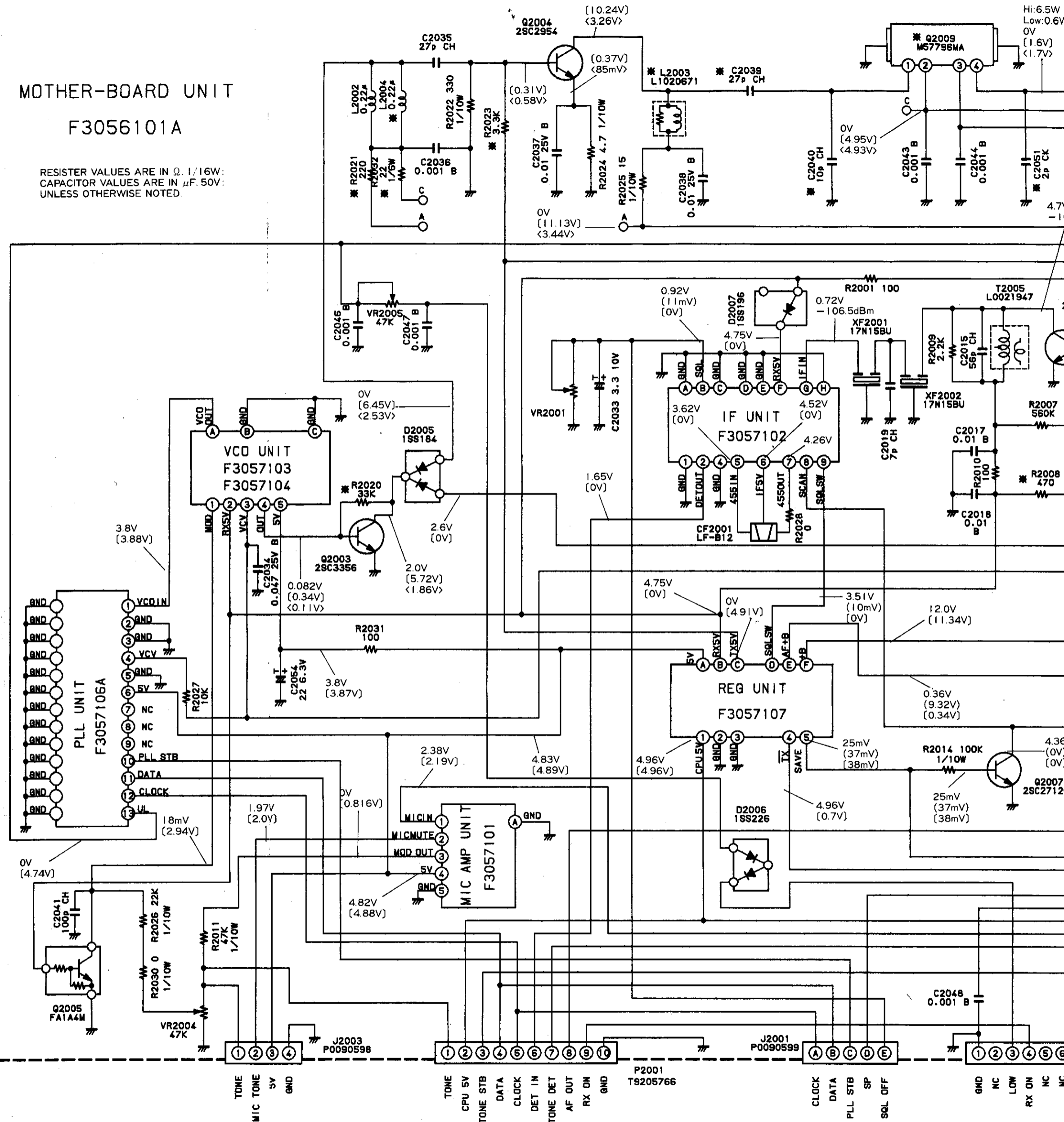

LINE	C2001	C2004	C2006	C2008	C2009	C2010	C2039	C2040	C2051	C1	Q2009	L2003	L2004	R2008	R2020	R2021	R2023	R2032	
A	3pCH	33pCH	3pCH	33pCH	33pCH	33pCH	27pCH	10pCH	2pCH	—	M57796MA	L1020671	—	470 Ω	33K Ω	220 Ω	3.3K Ω	—	A-A
C	2pCH	27pCH	1pCH	27pCH	27pCH	27pCH	15pCH	—	—	18pCH	M57796H	L0020744	L1190342	1.5K Ω	15K Ω	—	1.5K Ω	22 Ω 1/6W	C-C

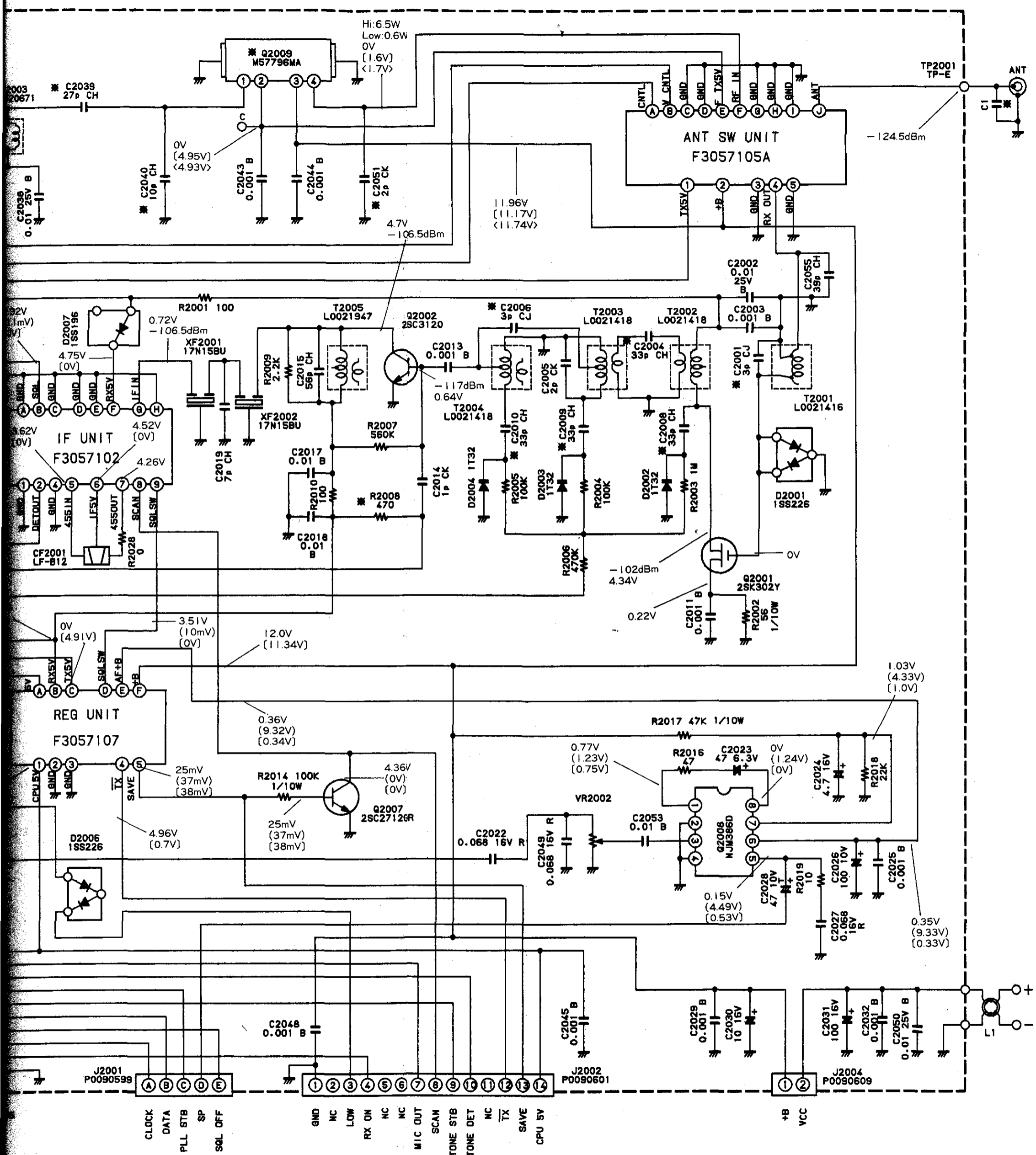

Q08	R2020	R2021	R2023	R2032	LINE
33K	33K	220	3.3K	—	A-A
15K	—	—	1.5K	22 1/6W	C-C

F3057102A Printed Circuit Board

CA0025001 PCB W/Components

C 0301	K22144802	CHIP CAP.	GRM39B103M25PT	0.01uF	25V	B
C 0302	K22174809	CHIP CAP.	GRM39B102M50PT	0.001uF	50V	B
C 0303	K22170207	CHIP CAP.	GRM40CH060D50PT	6pF	50V	CH
C 0304	K22170229	CHIP CAP.	GRM40CH560J50PT	56pF	50V	CH
C 0305	K22170237	CHIP CAP.	GRM40CH121J50PT	120pF	50V	CH
C 0306	K22120805	CHIP CAP.	GRM40R683M16PT	0.068uF	16V	R
C 0307	K22120805	CHIP CAP.	GRM40R683M16PT	0.068uF	16V	R
C 0308	K78080002	CHIP TA CAP.	F950J475MSAAF1Q2	4.7uF	6.3V	
C 0309	K22144802	CHIP CAP.	GRM39B103M25PT	0.01uF	25V	B
C 0310	K22170233	CHIP CAP.	GRM40CH820J50PT	82pF	50V	CH
C 0312	K22144802	CHIP CAP.	GRM39B103M25PT	0.01uF	25V	B
C 0313	K22120805	CHIP CAP.	GRM40R683M16PT	0.068uF	16V	R
C 0314	K22170247	CHIP CAP.	GRM40CH331J50PT	330pF	50V	CH
C 0315	K22170247	CHIP CAP.	GRM40CH331J50PT	330pF	50V	CH
C 0316	K22120805	CHIP CAP.	GRM40R683M16PT	0.068uF	16V	R
CD0301	H7900180	CERAMIC DISC	CDB455C7			
D 0301	G2070003	DIODE	1SS226 TE85R			
D 0302	G2070003	DIODE	1SS226 TE85R			
L 0301	L1690017	COIL	32CS 380LB-2R2M=P	2.2uH		
Q 0301	G3326207B	TRANSISTOR	2SC2620QBTR			
Q 0302	G1090859	IC	TK10487M			
R 0301	J24185152	CHIP RES.	RMC1/16 152JATP	1.5K		1/16W
R 0302	J24185224	CHIP RES.	RMC1/16 224JATP	220K		1/16W
R 0303	J24185473	CHIP RES.	RMC1/16 473JATP	47K		1/16W
R 0304	J24185471	CHIP RES.	RMC1/16 471JATP	470		1/16W
R 0305	J24185470	CHIP RES.	RMC1/16 470JATP	47		1/16W
R 0306	J24185683	CHIP RES.	RMC1/16 683JATP	68K		1/16W
R 0307	J24185102	CHIP RES.	RMC1/16 102JATP	1K		1/16W
R 0308	J24185182	CHIP RES.	RMC1/16 182JATP	1.8K		1/16W
R 0309	J24185102	CHIP RES.	RMC1/16 102JATP	1K		1/16W
R 0310	J24185564	CHIP RES.	RMC1/16 564JATP	560K		1/16W
R 0311	J24185153	CHIP RES.	RMC1/16 153JATP	15K		1/16W
R 0312	J24185332	CHIP RES.	RMC1/16 332JATP	3.3K		1/16W
R 0313	J24185102	CHIP RES.	RMC1/16 102JATP	1K		1/16W
R 0314	J24185562	CHIP RES.	RMC1/16 562JATP	5.6K		1/16W
R 0315	J24185000	CHIP RES.	RMC1/16 000JATP	0		1/16W
R 0318	J24185000	CHIP RES.	RMC1/16 000JATP	0		1/16W
X 0301	H0102913	XTAL	UM-1			16.845MHZ

IF UNIT(No.3**)

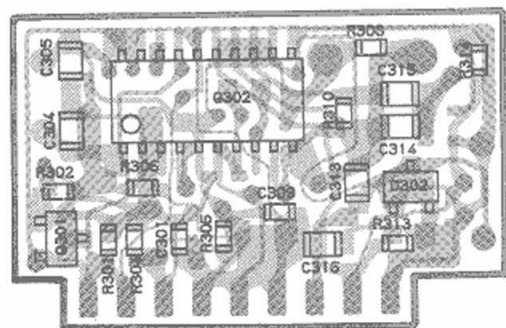
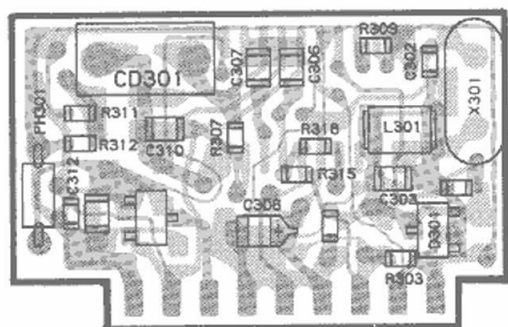

obverse view "mixed-component" side

obverse view "chip-only" side

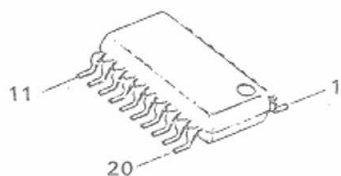

TK10487M(Q302)

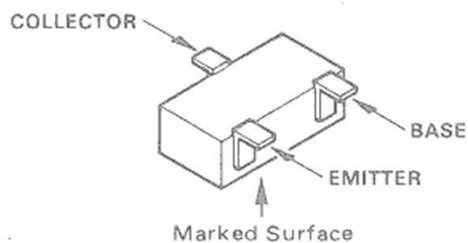

2SC2620(QB)(Q301)

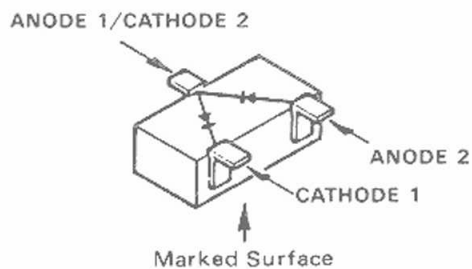

1SS226(C3)(D301,302)

IF UNIT F3057102A

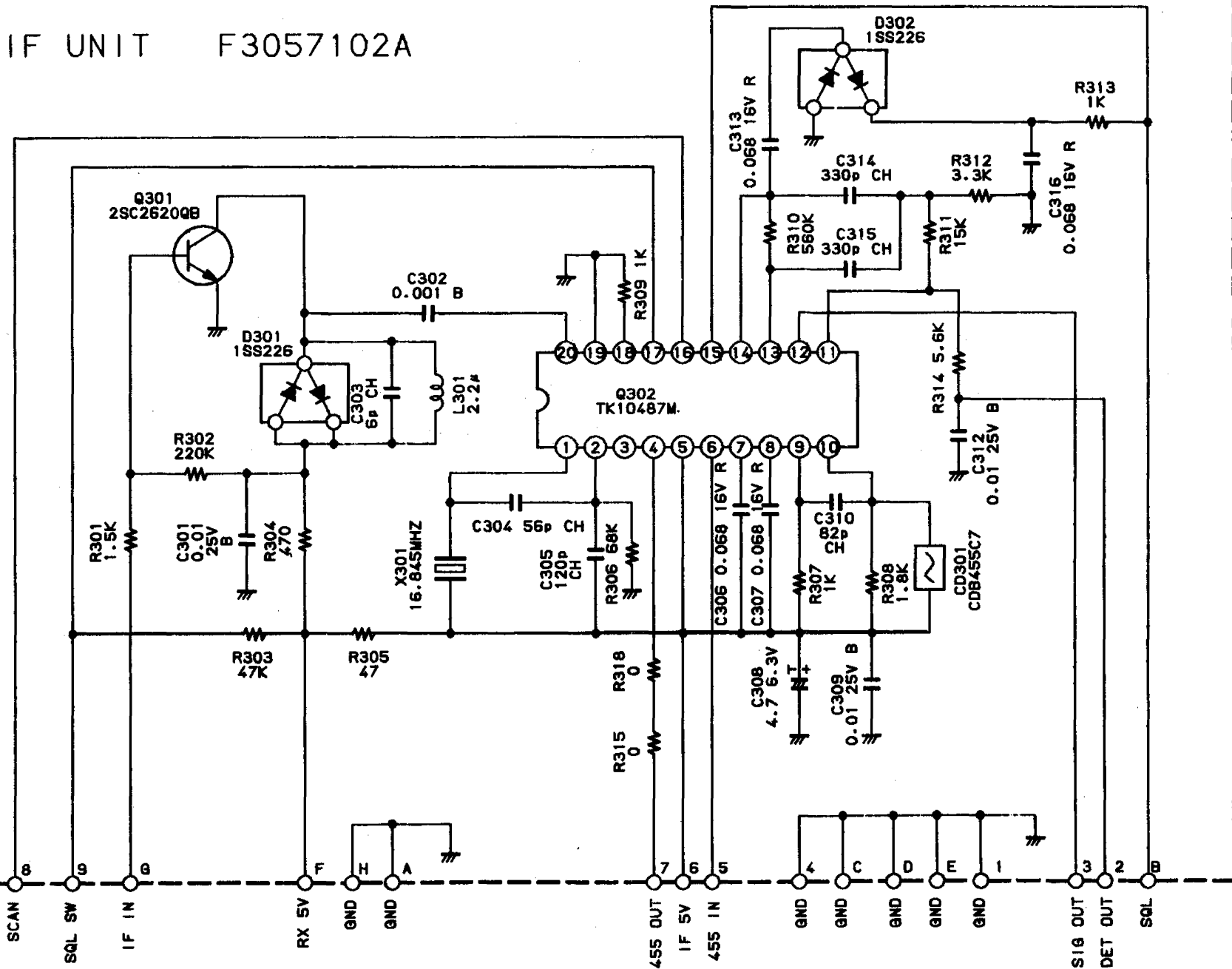

NOTE:
 RESISTOR VALUES ARE IN Ω./16W ;
 CAPACITOR VALUES ARE IN µF. 50V ;
 (T) CAPACITOR VALUES ARE TANTALUM ;
 INDUCTOR VALUES ARE IN H
 UNLESS OTHERWISE NOTED.

*** PLL UNIT ***

F3057106A Printed Circuit Board

CA0027001 PCB W/Components

C 0401	K22170206	CHIP CAP.	GRM40CH050C50PT	5pF	50V	CH
C 0402	K22170805	CHIP CAP.	GRM40B102M50PT	0.001uF	50V	B
C 0403	K22170805	CHIP CAP.	GRM40B102M50PT	0.001uF	50V	B
C 0404	K78080002	CHIP TA CAP.	F950J475MSAAF1Q2	4.7uF	6.3V	
C 0405	K22170805	CHIP CAP.	GRM40B102M50PT	0.001uF	50V	B
C 0406	K78080002	CHIP TA CAP.	F950J475MSAAF1Q2	4.7uF	6.3V	
C 0407	K22170805	CHIP CAP.	GRM40B102M50PT	0.001uF	50V	B
C 0408	K22170235	CHIP CAP.	GRM40CH101J50PT	100pF	50V	CH
C 0409	K22170235	CHIP CAP.	GRM40CH101J50PT	100pF	50V	CH
C 0410	K22170235	CHIP CAP.	GRM40CH101J50PT	100pF	50V	CH
C 0411	K22170231	CHIP CAP.	GRM40CH680J50PT	68pF	50V	CH
C 0412	K22170219	CHIP CAP.	GRM40CH220J50PT	22pF	50V	CH
C 0413	K22170805	CHIP CAP.	GRM40B102M50PT	0.001uF	50V	B
C 0414	K22170805	CHIP CAP.	GRM40B102M50PT	0.001uF	50V	B
C 0415	K22170805	CHIP CAP.	GRM40B102M50PT	0.001uF	50V	B
C 0416	K22141809	CHIP CAP.	GRM42-6B104M25PT	0.1uF	25V	B
C 0417	K22141809	CHIP CAP.	GRM42-6B104M25PT	0.1uF	25V	B
C 0418	K78100003	CHIP TA CAP.	F951A685MTAAF1Q2	6.8uF	10V	
C 0419	K22170235	CHIP CAP.	GRM40CH101J50PT	100pF	50V	CH
C 0420	K78080002	CHIP TA CAP.	F950J475MSAAF1Q2	4.7uF	6.3V	
C 0421	K22170204	CHIP CAP.	GRM40CJ030C50PT	3pF	50V	CJ
C 0422	K22170206	CHIP CAP.	GRM40CH050C50PT	5pF	50V	CH
D 0401	G2090118	DIODE	1SS97			
L 0401	L1190311	M.RFC	LAL02NA221K	220uH		
Q 0401	G1090725	IC	MC12017P			
Q 0402	G1090582	IC	MC145156			
R 0401	J24205103	CHIP RES.	RMC1/10T 103J	10K	1/10W	
R 0402	J24205220	CHIP RES.	RMC1/10T 220J	22	1/10W	
R 0403	J24185220	CHIP RES.	RMC1/16 220JATP	22	1/16W	
R 0404	J24205222	CHIP RES.	RMC1/10T 222J	2.2K	1/10W	
R 0405	J24205222	CHIP RES.	RMC1/10T 222J	2.2K	1/10W	
R 0406	J24205153	CHIP RES.	RMC1/10T 153J	15K	1/10W	STP 5
R 0406	J24205103	CHIP RES.	RMC1/10T 103J	10K	1/10W	STP 10
R 0406	J24205472	CHIP RES.	RMC1/10T 472J	4.7K	1/10W	STP 12.5
R 0407	J24205222	CHIP RES.	RMC1/10T 222J	2.2K	1/10W	
R 0408	J24205000	CHIP RES.	RMC1/10T 000J	0	1/10W	
R 0409	J24185102	CHIP RES.	RMC1/16 102JATP	1K	1/16W	
R 0410	J24185103	CHIP RES.	RMC1/16 103JATP	10K	1/16W	
X 0401	H0102800	XTAL	UM-2	10.240MHZ		STP 5
X 0401	H0102800	XTAL	UM-2	10.240MHZ		STP 10
X 0401	H0102799	XTAL	UM-2	12.800MHZ		STP 12.5

*** PLL UNIT ***

F3057106A Printed Circuit Board

CA0027001 PCB W/Components

C 0401	K22170206	CHIP CAP.	GRM40CH050C50PT	5pF	50V	CH
C 0402	K22170805	CHIP CAP.	GRM40B102M50PT	0.001uF	50V	B
C 0403	K22170805	CHIP CAP.	GRM40B102M50PT	0.001uF	50V	B
C 0404	K78080002	CHIP TA CAP.	F950J475MSAAF1Q2	4.7uF	6.3V	
C 0405	K22170805	CHIP CAP.	GRM40B102M50PT	0.001uF	50V	B
C 0406	K78080002	CHIP TA CAP.	F950J475MSAAF1Q2	4.7uF	6.3V	
C 0407	K22170805	CHIP CAP.	GRM40B102M50PT	0.001uF	50V	B
C 0408	K22170235	CHIP CAP.	GRM40CH101J50PT	100pF	50V	CH
C 0409	K22170235	CHIP CAP.	GRM40CH101J50PT	100pF	50V	CH
C 0410	K22170235	CHIP CAP.	GRM40CH101J50PT	100pF	50V	CH
C 0411	K22170231	CHIP CAP.	GRM40CH680J50PT	68pF	50V	CH
C 0412	K22170219	CHIP CAP.	GRM40CH220J50PT	22pF	50V	CH
C 0413	K22170805	CHIP CAP.	GRM40B102M50PT	0.001uF	50V	B
C 0414	K22170805	CHIP CAP.	GRM40B102M50PT	0.001uF	50V	B
C 0415	K22170805	CHIP CAP.	GRM40B102M50PT	0.001uF	50V	B
C 0416	K22141809	CHIP CAP.	GRM42-6B104M25PT	0.1uF	25V	B
C 0417	K22141809	CHIP CAP.	GRM42-6B104M25PT	0.1uF	25V	B
C 0418	K78100003	CHIP TA CAP.	F951A685MTAAF1Q2	6.8uF	10V	
C 0419	K22170235	CHIP CAP.	GRM40CH101J50PT	100pF	50V	CH
C 0420	K78080002	CHIP TA CAP.	F950J475MSAAF1Q2	4.7uF	6.3V	
C 0421	K22170204	CHIP CAP.	GRM40CJ030C50PT	3pF	50V	CJ
C 0422	K22170206	CHIP CAP.	GRM40CH050C50PT	5pF	50V	CH
D 0401	G2090118	DIODE	1SS97			
L 0401	L1190311	M.RFC	LAL02NA221K	220uH		
Q 0401	G1090725	IC	MC12017P			
Q 0402	G1090582	IC	MC145156			
R 0401	J24205103	CHIP RES.	RMC1/10T 103J	10K	1/10W	
R 0402	J24205220	CHIP RES.	RMC1/10T 220J	22	1/10W	
R 0403	J24185220	CHIP RES.	RMC1/16 220JATP	22	1/16W	
R 0404	J24205222	CHIP RES.	RMC1/10T 222J	2.2K	1/10W	
R 0405	J24205222	CHIP RES.	RMC1/10T 222J	2.2K	1/10W	
R 0406	J24205153	CHIP RES.	RMC1/10T 153J	15K	1/10W	STP 5
R 0406	J24205103	CHIP RES.	RMC1/10T 103J	10K	1/10W	STP 10
R 0406	J24205472	CHIP RES.	RMC1/10T 472J	4.7K	1/10W	STP 12.5
R 0407	J24205222	CHIP RES.	RMC1/10T 222J	2.2K	1/10W	
R 0408	J24205000	CHIP RES.	RMC1/10T 000J	0	1/10W	
R 0409	J24185102	CHIP RES.	RMC1/16 102JATP	1K	1/16W	
R 0410	J24185103	CHIP RES.	RMC1/16 103JATP	10K	1/16W	
X 0401	H0102800	XTAL	UM-2	10.240MHZ		STP 5
X 0401	H0102800	XTAL	UM-2	10.240MHZ		STP 10
X 0401	H0102799	XTAL	UM-2	12.800MHZ		STP 12.5

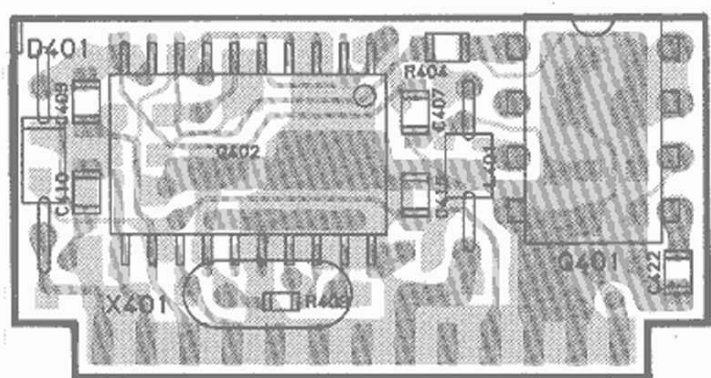

obverse view "mixed-component" side

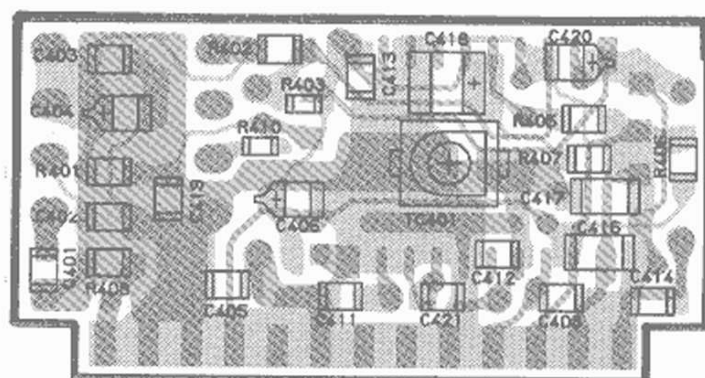

obverse view "chip-only" side

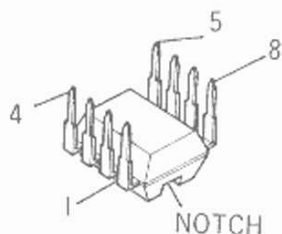

MC12017P(Q401)

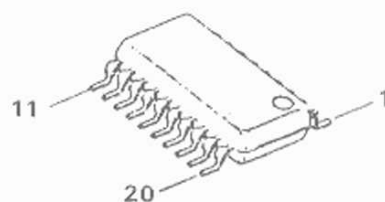

MC145156(Q402)

PLL UNIT F3057106A

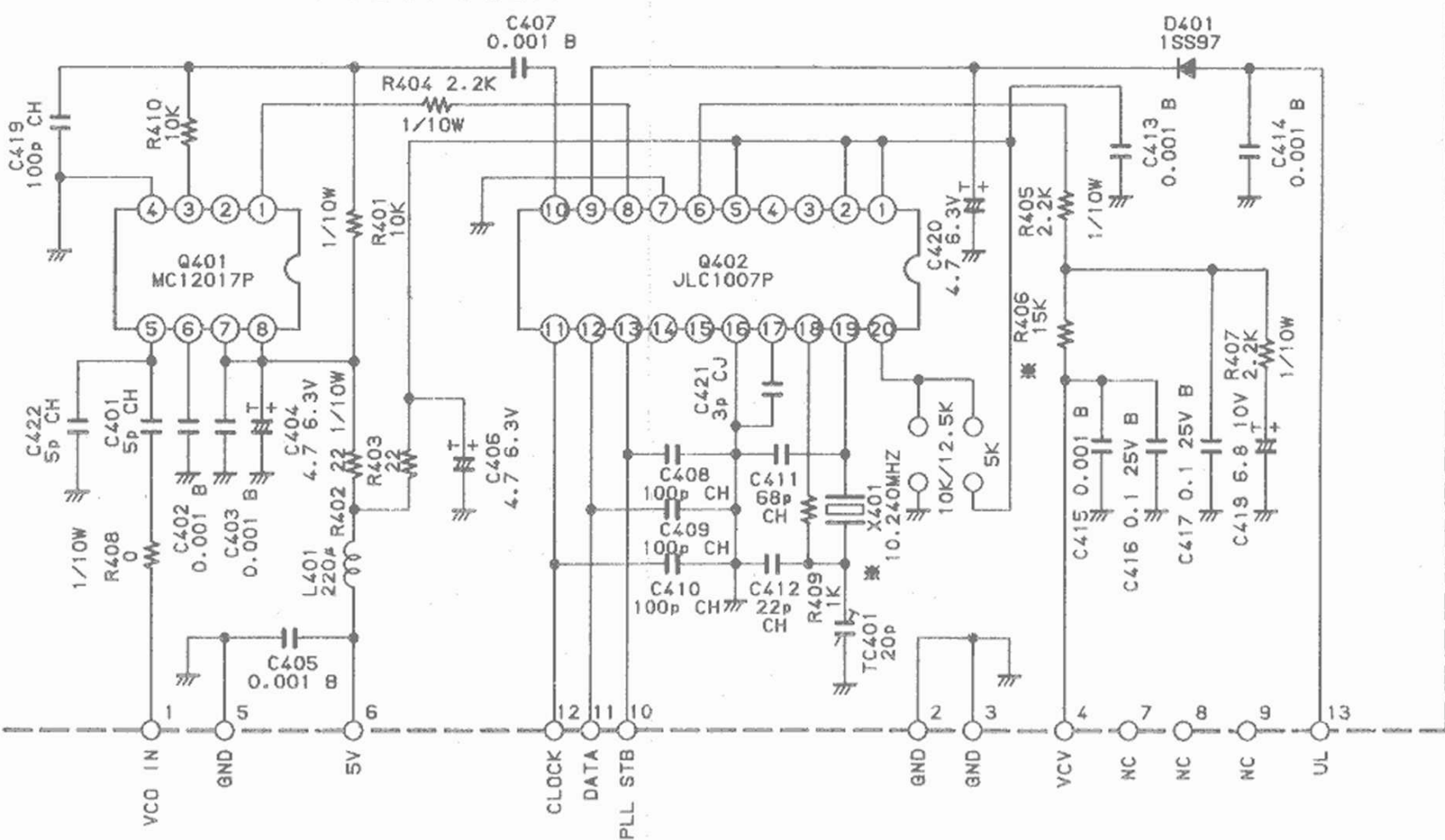

	5KHz	10KHz	12.5KHz
R406	15K	10K	4.7K
X401	10.24MHz	10.24MHz	12.8MHz
	H0102800	H0102800	H0102799

NOTE:
 RESISTOR VALUES ARE IN Ω, 1/16W ;
 CAPACITOR VALUES ARE IN μF, 50V ;
 (T) CAPACITOR VALUES ARE TANTALUM ;
 INDUCTOR VALUES ARE IN H
 UNLESS OTHERWISE NOTED.

F3057103 Printed Circuit Board(OSC)
Printed Circuit Board(BUF)

CP1944001 PCB W/Components(OSC,BUF)
CP1944002 PCB W/Components(OSC,BUF)

TYP A

TYP C

C 0501	K22170215	CHIP CAP.	GRM40CH150J50PT	15pF	50V	CH	TYP C
C 0501	K22170323	CHIP CAP.	GRM40UJ330J50PT	33pF	50V	UJ	TYP A
C 0502	K22170243	CHIP CAP.	GRM40CH221J50PT	220pF	50V	CH	
C 0503	K22170211	CHIP CAP.	GRM40CH100D50PT	10pF	50V	CH	
C 0504	K78080003	CHIP TA CAP.	F950J106MTAAF1Q2	10uF	6.3V		
C 0505	K22170805	CHIP CAP.	GRM40B102M50PT	0.001uF	50V	B	
C 0506	K22170306	CHIP CAP.	GRM40UJ050C50PT	5pF	50V	UJ	TYP A
C 0506	K22170311	CHIP CAP.	GRM40UJ100D50PT	10pF	50V	UJ	TYP C
C 0507	K22170311	CHIP CAP.	GRM40UJ100D50PT	10pF	50V	UJ	
C 0508	K22170201	CHIP CAP.	GRM40CK0R5C50PT	0.5pF	50V	CK	
C 0509	K78080002	CHIP TA CAP.	F950J475MSAAF1Q2	4.7uF	6.3V		
C 0510	K22170805	CHIP CAP.	GRM40B102M50PT	0.001uF	50V	B	
C 0511	K22170247	CHIP CAP.	GRM40CH331J50PT	330pF	50V	CH	

D 0501	G2090297	DIODE	1SS110				
D 0502	G2070040	DIODE	1T33-T7				
D 0503	G2070040	DIODE	1T33-T7				

L 0501	L1690016	COIL	32CS 380LB-1R0M=P	1uH			
L 0502	L1690016	COIL	32CS 380LB-1R0M=P	1uH			
L 0503	L1690016	COIL	32CS 380LB-1R0M=P	1uH			
L 0504	L1690025	COIL	32CS 380NB-R22M=P	0.22uH			

Q 0501	G3802387S	FET	2SK238-T2B K17				
Q 0502	G3327597B	TRANSISTOR	2SC2759 T2B-U22				

R 0501	J24205222	CHIP RES.	RMC1/10 222J	2.2K		1/10W	
R 0503	J24205103	CHIP RES.	RMC1/10 103J	10K		1/10W	
R 0504	J24205470	CHIP RES.	RMC1/10 470J	47		1/10W	
R 0505	J24205470	CHIP RES.	RMC1/10 470J	47		1/10W	
R 0506	J24205683	CHIP RES.	RMC1/10 683J	68K		1/10W	

T 0501	L0021709	COIL	R12-F474X			1/10W	TYP A
T 0501	L0021684A	COIL	R12-E991X				TYP C

TC0501	K91000152	TRIMMER CAP.	ECR-JA040G12X	40pF			
--------	-----------	--------------	---------------	------	--	--	--

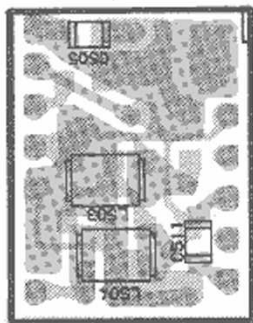

obverse view "top" side

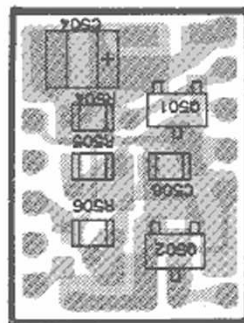

obverse view "bottom" side

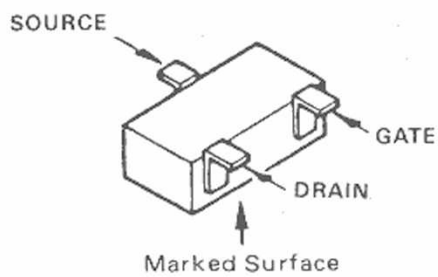

2SK238(K17) (Q501)

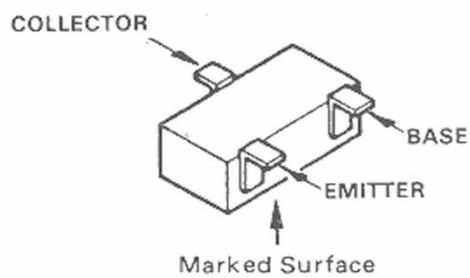

2SC2759 (U22) (Q502)

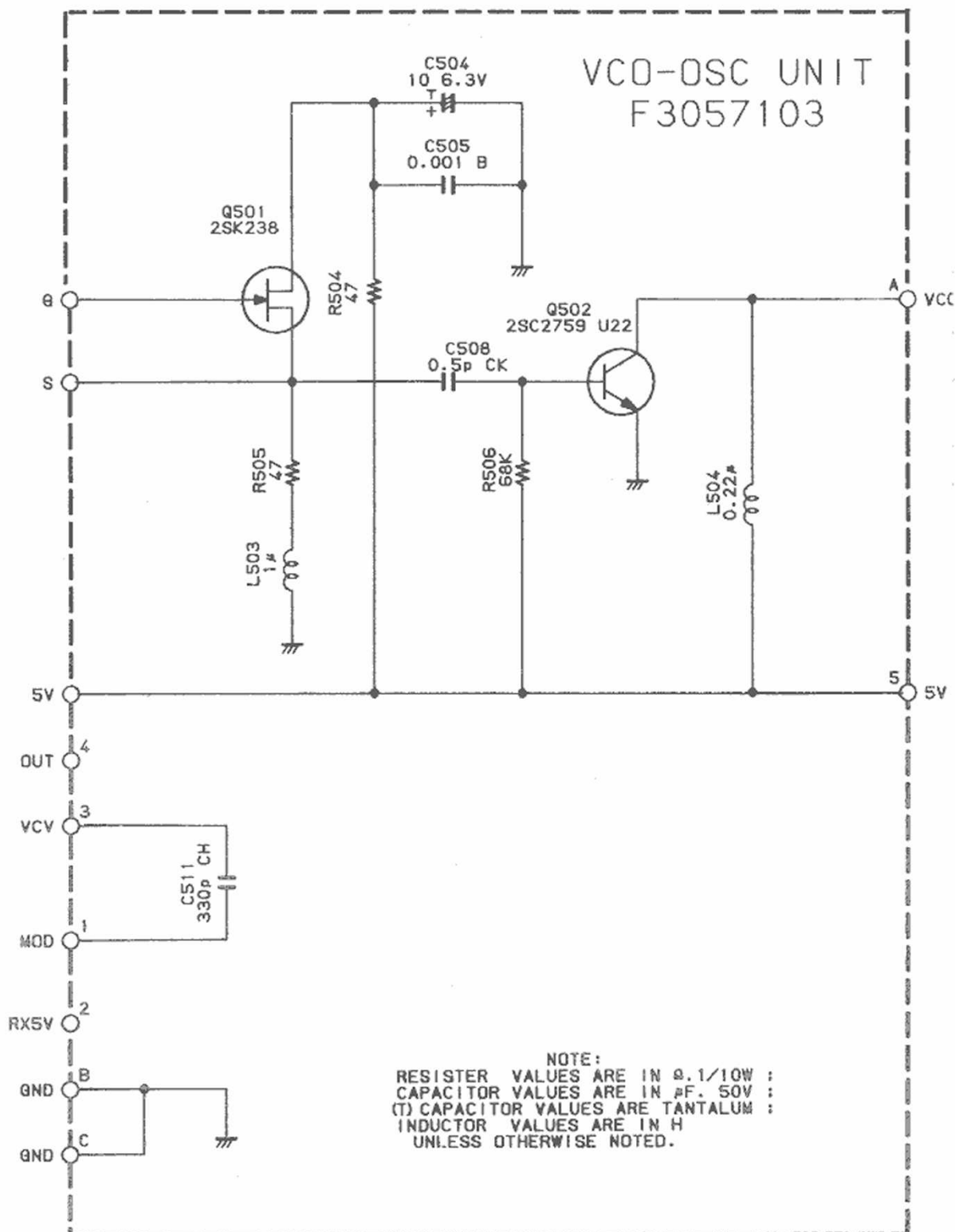

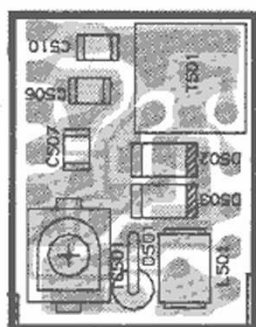

obverse view "top" side

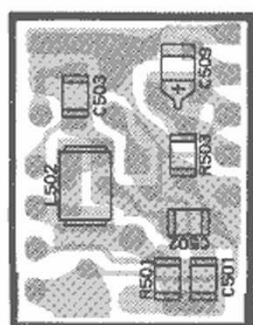

obverse view "bottom" side

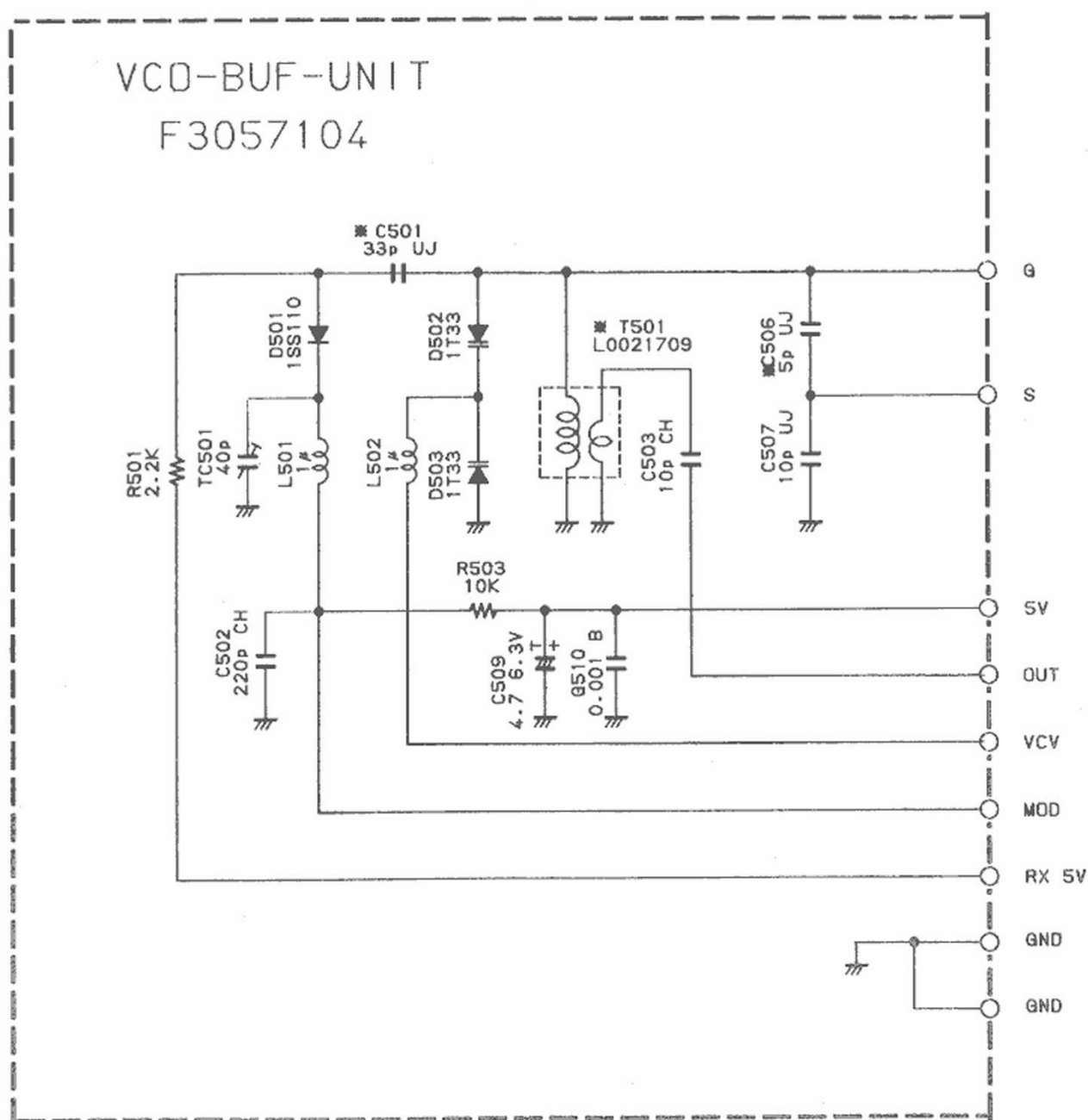

	A type	C type
C501	33p UJ	15p CH
C506	5p UJ	10p UJ
T501	L0021709	L0021684A

NOTE:
 RESISTER VALUES ARE IN Ω , 1/10W ;
 CAPACITOR VALUES ARE IN μ F, 50V ;
 (T) CAPACITOR VALUES ARE TANTALUM ;
 INDUCTOR VALUES ARE IN H
 UNLESS OTHERWISE NOTED.

F3057107A Printed Circuit Board

CA0028001 PCB W/Components

C 0601	K22174809	CHIP CAP.	GRM39B102M50PT	0.001uF	50V	B
C 0602	K78100003	CHIP TA CAP.	F951A685MTAAF1Q2	6.8uF	10V	
C 0603	K22174809	CHIP CAP.	GRM39B102M50PT	0.001uF	50V	B
C 0604	K22174809	CHIP CAP.	GRM39B102M50PT	0.001uF	50V	B
C 0605	K78120002	CHIP TA CAP.	F951C225MSAAF1Q2	2.2uF	16V	
C 0606	K22174809	CHIP CAP.	GRM39B102M50PT	0.001uF	50V	B
C 0607	K78080013	CHIP TA CAP.	F950J476MFCAF1	47uF	6.3V	
C 0608	K22174809	CHIP CAP.	GRM39B102M50PT	0.001uF	50V	B
C 0609	K22174809	CHIP CAP.	GRM39B102M50PT	0.001uF	50V	B
C 0610	K22174809	CHIP CAP.	GRM39B102M50PT	0.001uF	50V	B
C 0611	K22174809	CHIP CAP.	GRM39B102M50PT	0.001uF	50V	B
C 0612	K22174809	CHIP CAP.	GRM39B102M50PT	0.001uF	50V	B
C 0613	K22174809	CHIP CAP.	GRM39B102M50PT	0.001uF	50V	B
D 0601	G2070048	DIODE	1SS272 TE85R			
D 0602	G2090153	DIODE	RD10EB1			
D 0603	G2070009	DIODE	1SS184 TE85R			
Q 0601	G3207997L	TRANSISTOR	2SB799-T2ML			
Q 0602	G3327127G	TRANSISTOR	2SC2712GR TE85R			
Q 0603	G3327127G	TRANSISTOR	2SC2712GR TE85R			
Q 0604	G1090785	IC	LM2931AZ-5.0			
Q 0605	G3111627G	TRANSISTOR	2SA1162GR TE85R			
Q 0606	G3111627G	TRANSISTOR	2SA1162GR TE85R			
Q 0607	G3111627G	TRANSISTOR	2SA1162GR TE85R			
Q 0608	G3327127G	TRANSISTOR	2SC2712GR TE85R			
R 0601	J24205101	CHIP RES.	RMC 1/10T 101J	100		
R 0602	J01245829	CARBON FILM RES.	RD14TJ8R2 8.2	8.2		
R 0603	J24185223	CHIP RES.	RMC1/16 223JATP	22K		1/16W
R 0604	J24185104	CHIP RES.	RMC1/16 104JATP	100K		1/16W
R 0605	J24185103	CHIP RES.	RMC1/16 103JATP	10K		1/16W
R 0606	J24185472	CHIP RES.	RMC1/16 472JATP	4.7K		1/16W
R 0607	J24185472	CHIP RES.	RMC1/16 472JATP	4.7K		1/16W
R 0608	J24185222	CHIP RES.	RMC1/16 222JATP	2.2K		1/16W
R 0609	J24185104	CHIP RES.	RMC1/16 104JATP	100K		1/16W
R 0610	J24185104	CHIP RES.	RMC1/16 104JATP	100K		1/16W
R 0611	J24185103	CHIP RES.	RMC1/16 103JATP	10K		1/16W
R 0612	J24185472	CHIP RES.	RMC1/16 472JATP	4.7K		1/16W

REG UNIT(No.6 **)

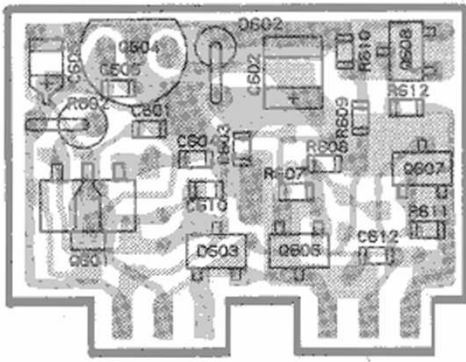

obverse view "mixed-component" side

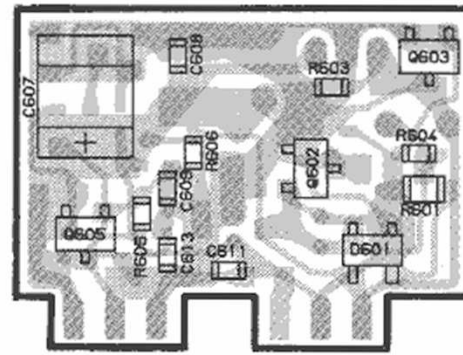

obverse view "chip-only" side

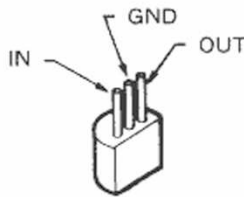

LM2931AZ-5.0(Q604)

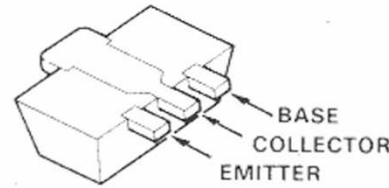

2SB799(ML)(Q601)

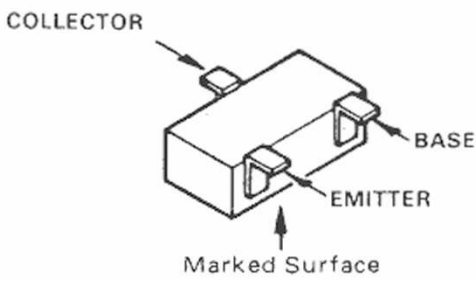

2SA1162GR(SG)
(Q605, 606, 607)
2SC2712GR(LG)
(Q602, 603, 608)

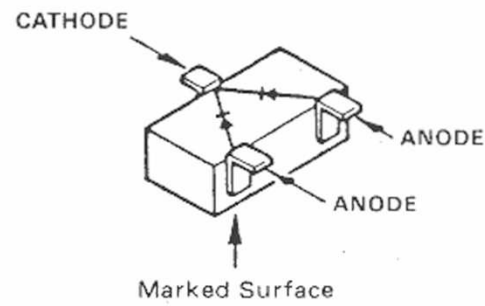

1SS184(B3)(D603)

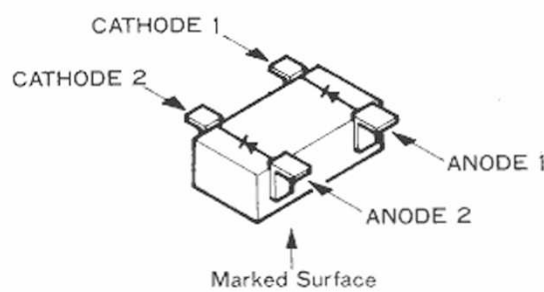

1SS272(A1)(D601)

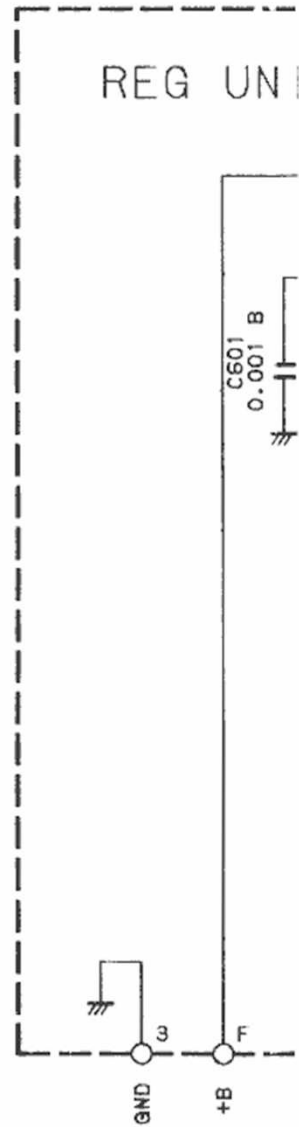

T F3057107A

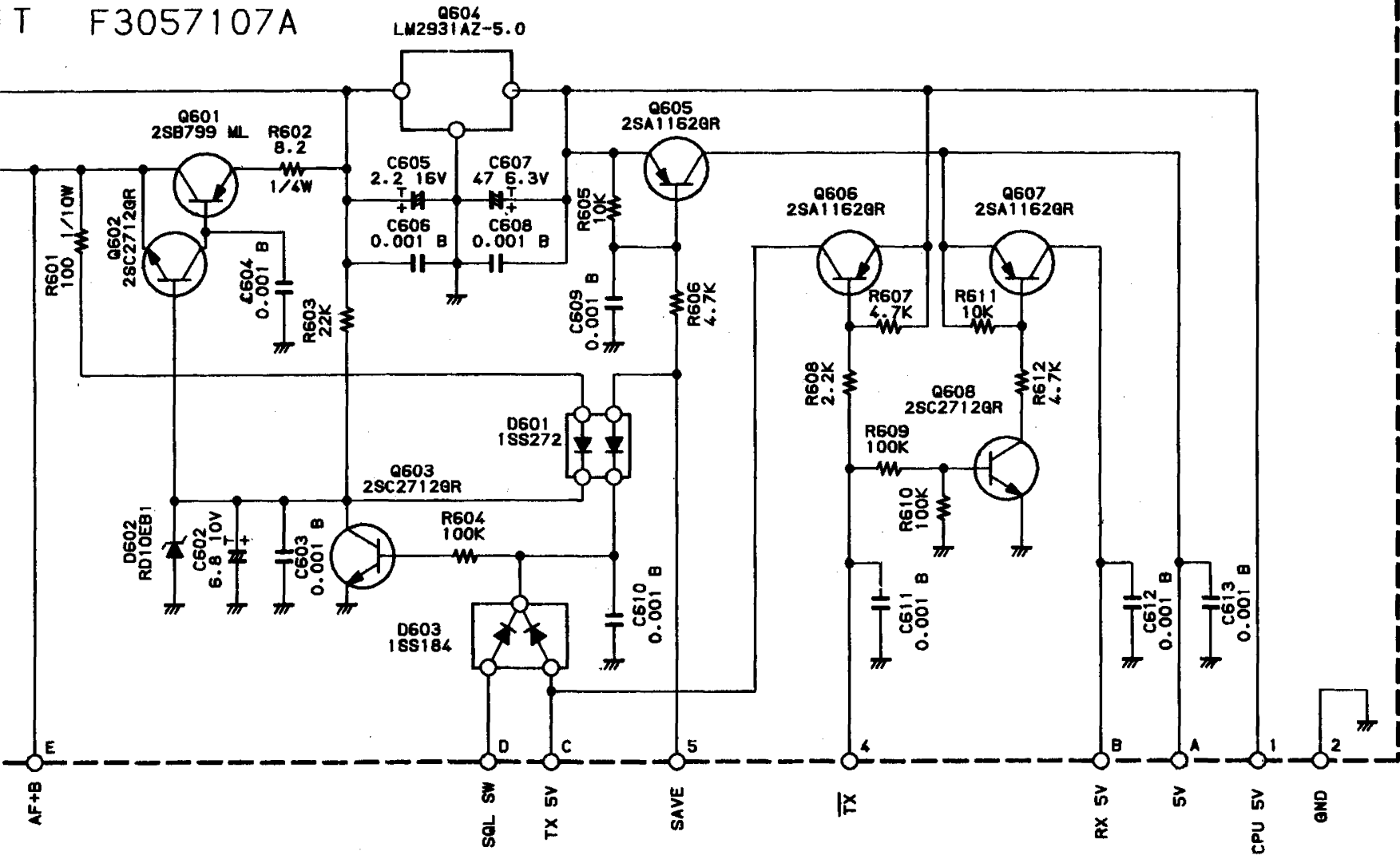

NOTE:

RESISTER VALUES ARE IN Ω, 1/16W ;
 CAPACITOR VALUES ARE IN µF, 50V ;
 (T) CAPACITOR VALUES ARE TANTALUM ;
 INDUCTOR VALUES ARE IN H
 UNLESS OTHERWISE NOTED.

*** MIC AMP UNIT ***

F3057101 Printed Circuit Board

CA0026001 PCB W/Components

C 0703	K22170817	CHIP CAP.	GRM40B103M50PT	0.01uF	50V	B
C 0704	K22141809	CHIP CAP.	GRM42-6B104M25PT	0.1uF	25V	B
C 0705	K22170821	CHIP CAP.	GRM40B223M50PT	0.022uF	50V	B
C 0706	K78120013	CHIP TA CAP.	F951C105MRAAF1Q2	1uF	16V	
C 0707	K22170817	CHIP CAP.	GRM40B103M50PT	0.01uF	50V	B
C 0708	K22174805	CHIP CAP.	GRM39B471M50PT	470pF	50V	B
C 0709	K22170807	CHIP CAP.	GRM40B152M50PT	0.0015uF	50V	B
C 0710	K22174235	CHIP CAP.	GRM39CH101J50PT	100pF	50V	CH
C 0711	K22174809	CHIP CAP.	GRM39B102M50PT	0.001uF	50V	B
C 0712	K22141809	CHIP CAP.	GRM42-6B104M25PT	0.1uF	25V	B
Q 0701	G1090908	IC	NJM2902M			
R 0703	J24205225	CHIP RES.	RMC1/10 225J	2.2M	1/10W	
R 0704	J24185153	CHIP RES.	RMC1/16 153JATP	15K	1/16W	
R 0705	J24185223	CHIP RES.	RMC1/16 223JATP	22K	1/16W	
R 0706	J24185185	CHIP RES.	RMC1/16 185JATP	1.8M	1/16W	
R 0707	J24185563	CHIP RES.	RMC1/16 563JATP	56K	1/16W	
R 0708	J24185333	CHIP RES.	RMC1/16 333JATP	33K	1/16W	
R 0709	J24185103	CHIP RES.	RMC1/16 103JATP	10K	1/16W	
R 0710	J24185562	CHIP RES.	RMC1/16 562JATP	5.6K	1/16W	
R 0711	J24185104	CHIP RES.	RMC1/16 104JATP	100K	1/16W	
R 0712	J24185104	CHIP RES.	RMC1/16 104JATP	100K	1/16W	
R 0713	J24185104	CHIP RES.	RMC1/16 104JATP	100K	1/16W	
R 0714	J24185225	CHIP RES.	RMC1/16 225JATP	2.2M	1/16W	
R 0715	J24205153	CHIP RES.	RMC1/10 153J	15K	1/10W	

MIC AMP UNIT (No.7 **)

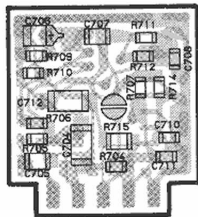
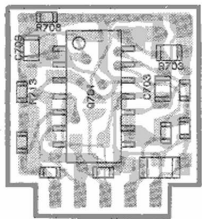

obverse view "mixed-component" side

obverse view "chip-only" side

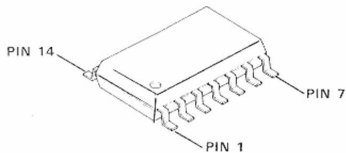

MJM2902M(Q701)

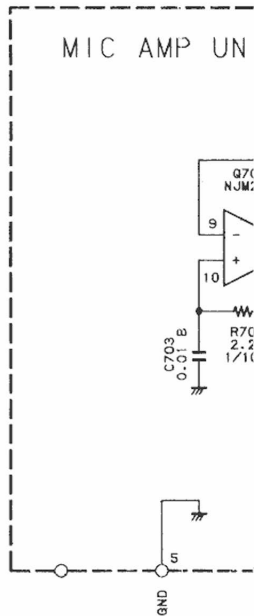

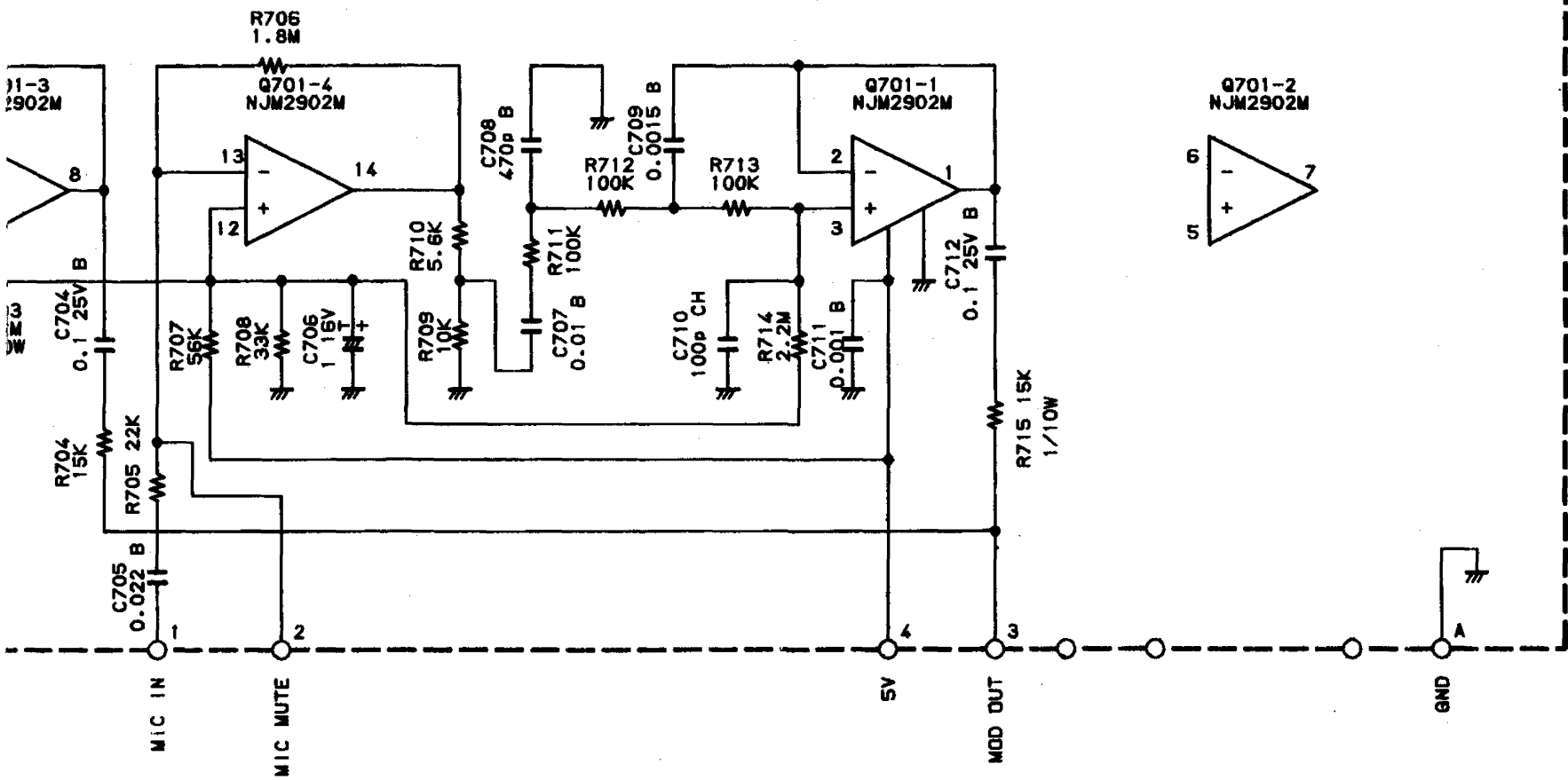

NOTE:
 RESISTOR VALUES ARE IN Ω, 1/16W ;
 CAPACITOR VALUES ARE IN µF, 50V ;
 (T) CAPACITOR VALUES ARE TANTALUM ;
 UNLESS OTHERWISE NOTED.

F3057105A Printed Circuit Board

	CA0024001	PCB W/Components						TYP A
	CA0024002	PCB W/Components						TYP C
C 0901	K22170805	CHIP CAP.	GRM40B102M50PT	0.001uF	50V	B		
C 0902	K70127106	TANTALUM CAP.	DN1C100M1S	10uF	16V			
C 0903	K22170805	CHIP CAP.	GRM40B102M50PT	0.001uF	50V	B		
C 0904	K40179033	AL. ELECTRO. CAP.	RC3-50VR47M	0.47uF	50V			
C 0905	K22170805	CHIP CAP.	GRM40B102M50PT	0.001uF	50V	B		
C 0906	K40129052	AL. ELECTRO. CAP.	RC3-16V100M	10uF	16V			
C 0907	K22170805	CHIP CAP.	GRM40B102M50PT	0.001uF	50V	B		
C 0908	K22170805	CHIP CAP.	GRM40B102M50PT	0.001uF	50V	B		
C 0909	K22170805	CHIP CAP.	GRM40B102M50PT	0.001uF	50V	B		
C 0910	K22170805	CHIP CAP.	GRM40B102M50PT	0.001uF	50V	B		
C 0911	K22170805	CHIP CAP.	GRM40B102M50PT	0.001uF	50V	B		
C 0912	K22170805	CHIP CAP.	GRM40B102M50PT	0.001uF	50V	B		
C 0913	K22170223	CHIP CAP.	GRM40CH330J50PT	33pF	50V	CH		
C 0914	K22170211	CHIP CAP.	GRM40CH100D50PT	10pF	50V	CH		TYP A
C 0914	K22170213	CHIP CAP.	GRM40CH120J50PT	12pF	50V	CH		TYP C
C 0915	K22170223	CHIP CAP.	GRM40CH330J50PT	33pF	50V	CH		
C 0916	K22170209	CHIP CAP.	GRM40CH080D50PT	8pF	50V	CH		TYP A
C 0916	K22170208	CHIP CAP.	GRM40CH070D50PT	7pF	50V	CH		TYP C
C 0917	K22170217	CHIP CAP.	GRM40CH180J50PT	18pF	50V	CH		TYP A
D 0901	G2090027	DIODE	1SS53					
D 0902	G2090027	DIODE	1SS53					
D 0903	G2070003	DIODE	1SS226 TE85R					
L 0901	L1190344	M. RFC	LAL02KR100K	10uH				
L 0902	L0021683	COIL	L0021683					
L 0903	L0021796A	COIL	L0021796A					TYP C
L 0903	L0021682	COIL	L0021682					TYP A
L 0904	L0021683	COIL	L0021683					TYP A
L 0904	L0021682	COIL	L0021682					TYP C
Q 0901	G3207997L	TRANSISTOR	2SB799-ML					
Q 0902	G3327127G	TRANSISTOR	2SC2712GR TE85R					
Q 0903	G3327127G	TRANSISTOR	2SC2712GR TE85R					
Q 0904	G3327127G	TRANSISTOR	2SC2712GR TE85R					
Q 0905	G3207997L	TRANSISTOR	2SB799-ML					
R 0901	J24205222	CHIP RES.	RMC1/10 222J	2.2K		1/10W		
R 0902	J24205473	CHIP RES.	RMC1/10 473J	47K		1/10W		
R 0903	J24205471	CHIP RES.	RMC1/10 471J	470		1/10W		
R 0904	J24205222	CHIP RES.	RMC1/10 222J	2.2K		1/10W		
R 0905	J24205221	CHIP RES.	RMC1/10 221J	220		1/10W		
R 0906	J24205222	CHIP RES.	RMC1/10 222J	2.2K		1/10W		

ANT SW UNIT (No.9 **)

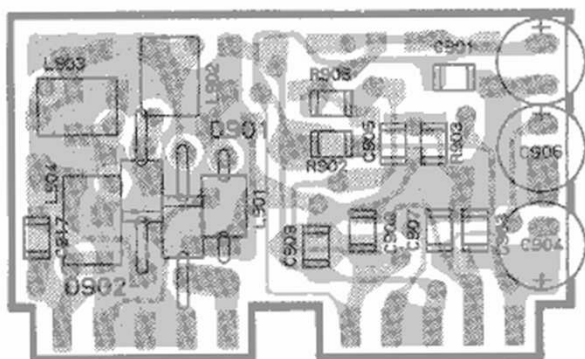

obverse view "mixed-component" side

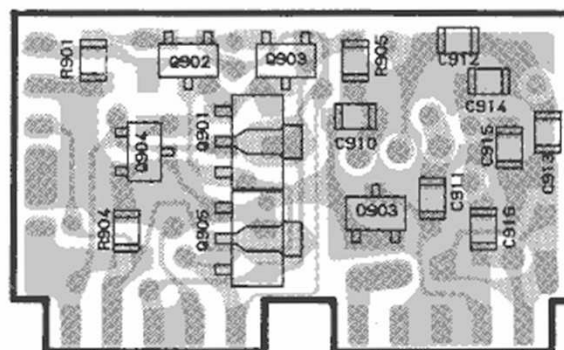

obverse view "chip-only" side

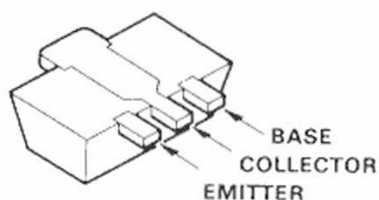

2SB799(ML)
(Q901, Q905)

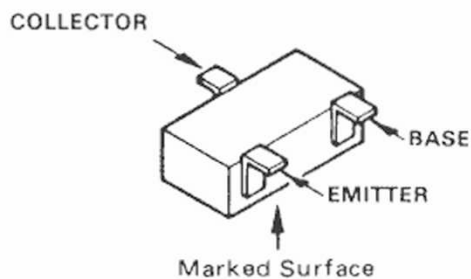

2SC2712GR(LG)
(Q902, 903, 904)

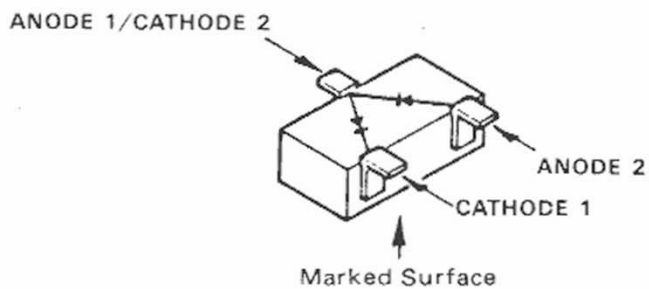

1SS226(C3) (D903)

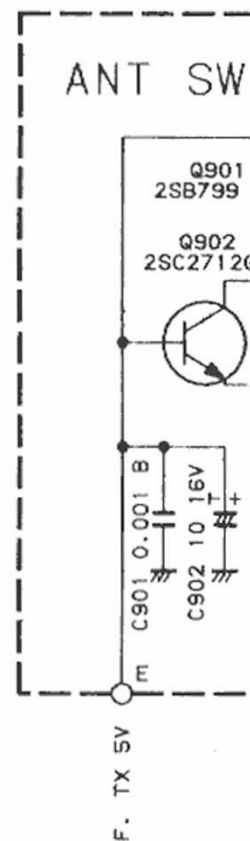

UNIT F3057105A

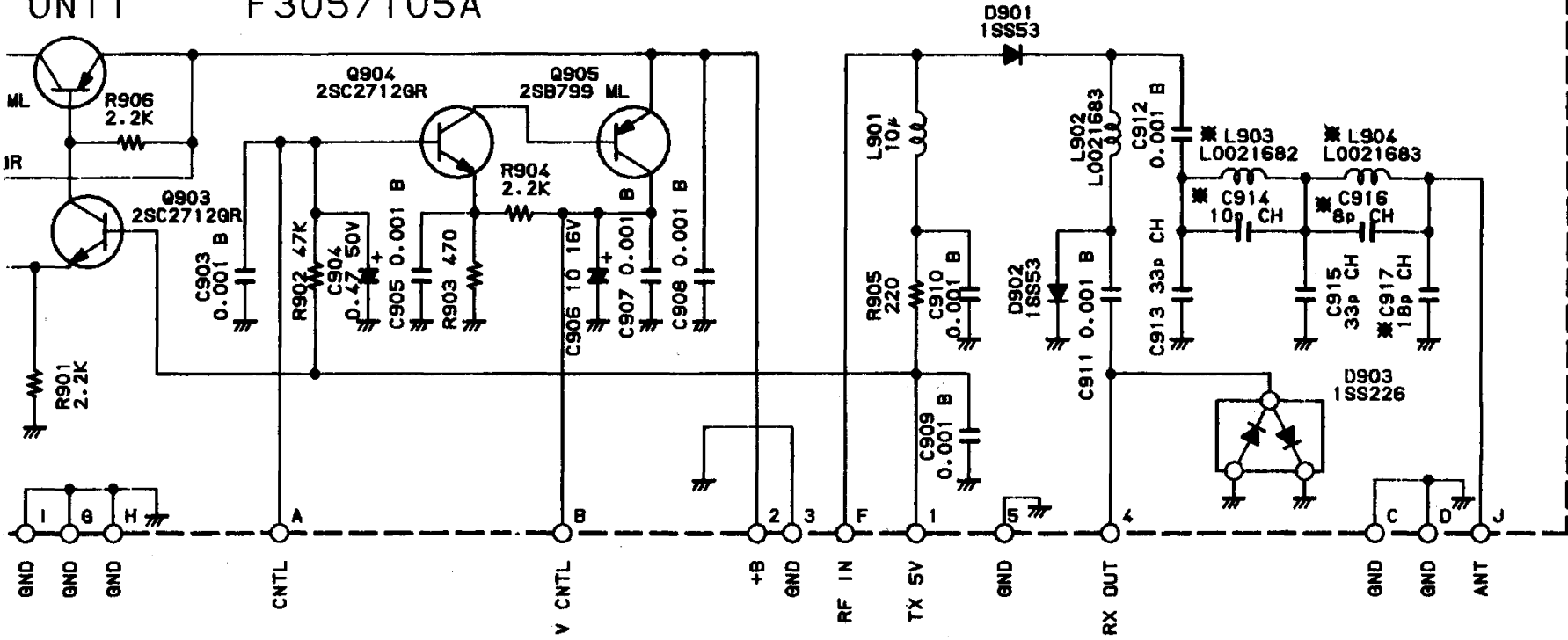

	A type	C type
C914	10p CH	12p CH
C916	8p CH	7p CH
C917	18p CH	—
L903	L0021682	L0021796A
L904	L0021683	L0021682

NOTE:
 RESISTOR VALUES ARE IN Ω , 1/10W ;
 CAPACITOR VALUES ARE IN μ F, 50V ;
 (T) CAPACITOR VALUES ARE TANTALUM ;
 INDUCTOR VALUES ARE IN H
 UNLESS OTHERWISE NOTED.

F3056102A Printed Circuit Board

CA0023001 PCB W/Components

C 1001	K22174809	CHIP CAP.	GRM39B102M50PT	0.001uF	50V	B
C 1002	K22144802	CHIP CAP.	GRM39B103M25PT	0.01uF	25V	B
C 1003	K78160025	CHIP TA. CAP.	TESVA1V104M1-8R	0.1uF	35V	
C 1004	K22144802	CHIP CAP.	GRM39B103M25PT	0.01uF	25V	B
C 1005	K22174809	CHIP CAP.	GRM39B102M50PT	0.001uF	50V	B
C 1006	K22174235	CHIP CAP.	GRM39CH101J50PT	100pF	50V	CH
C 1007	K22174235	CHIP CAP.	GRM39CH101J50PT	100pF	50V	CH
C 1008	K22144802	CHIP CAP.	GRM39B103M25PT	0.01uF	25V	B
C 1009	K22144802	CHIP CAP.	GRM39B103M25PT	0.01uF	25V	B
C 1010	K22174809	CHIP CAP.	GRM39B102M50PT	0.001uF	50V	B
C 1011	K22174235	CHIP CAP.	GRM39CH101J50PT	100pF	50V	CH
C 1012	K22174235	CHIP CAP.	GRM39CH101J50PT	100pF	50V	CH
C 1013	K22174235	CHIP CAP.	GRM39CH101J50PT	100pF	50V	CH
C 1014	K22174809	CHIP CAP.	GRM39B102M50PT	0.001uF	50V	B
C 1015	K22174809	CHIP CAP.	GRM39B102M50PT	0.001uF	50V	B
C 1016	K22144802	CHIP CAP.	GRM39B103M25PT	0.01uF	25V	B
C 1017	K22174809	CHIP CAP.	GRM39B102M50PT	0.001uF	50V	B
C 1018	K22174809	CHIP CAP.	GRM39B102M50PT	0.001uF	50V	B
C 1019	K22174809	CHIP CAP.	GRM39B102M50PT	0.001uF	50V	B
C 1020	K22174809	CHIP CAP.	GRM39B102M50PT	0.001uF	50V	B
C 1021	K22174809	CHIP CAP.	GRM39B102M50PT	0.001uF	50V	B
C 1022	K22174235	CHIP CAP.	GRM39CH101J50PT	100pF	50V	CH
C 1023	K22174809	CHIP CAP.	GRM39B102M50PT	0.001uF	50V	B
C 1024	K22174809	CHIP CAP.	GRM39B102M50PT	0.001uF	50V	B
C 1025	K22174809	CHIP CAP.	GRM39B102M50PT	0.001uF	50V	B
C 1026	K22174809	CHIP CAP.	GRM39B102M50PT	0.001uF	50V	B
C 1028	K78080003	CHIP TA. CAP.	F950J106MTAAAF1Q2	10uF	6.3V	
C 1029	K22174809	CHIP CAP.	GRM39B102M50PT	0.001uF	50V	B
C 1030	K22174809	CHIP CAP.	GRM39B102M50PT	0.001uF	50V	B
C 1031	K22174809	CHIP CAP.	GRM39B102M50PT	0.001uF	50V	B
C 1032	K22174809	CHIP CAP.	GRM39B102M50PT	0.001uF	50V	B
C 1033	K22174809	CHIP CAP.	GRM39B102M50PT	0.001uF	50V	B
C 1034	K78080002	CHIP TA. CAP.	F950J475MSAAAF1Q2	4.7uF	6.3V	
C 1035	K78080003	CHIP TA. CAP.	F950J106MTAAAF1Q2	10uF	6.3V	
C 1037	K22174809	CHIP CAP.	GRM39B102M50PT	0.001uF	50V	B
C 1038	K22174809	CHIP CAP.	GRM39B102M50PT	0.001uF	50V	B
C 1039	K22174809	CHIP CAP.	GRM39B102M50PT	0.001uF	50V	B
C 1040	K22174809	CHIP CAP.	GRM39B102M50PT	0.001uF	50V	B
C 1041	K22174809	CHIP CAP.	GRM39B102M50PT	0.001uF	50V	B
C 1042	K22174809	CHIP CAP.	GRM39B102M50PT	0.001uF	50V	B
C 1043	K22174809	CHIP CAP.	GRM39B102M50PT	0.001uF	50V	B
C 1044	K22174809	CHIP CAP.	GRM39B102M50PT	0.001uF	50V	B
C 1045	K70087476	TANTALUM CAP.	DNOJ470M1S	47uF	6.3V	
C 1046	K22174235	CHIP CAP.	GRM39CH101J50PT	100pF	50V	CH
C 1047	K22174809	CHIP CAP.	GRM39B102M50PT	0.001uF	50V	B
C 1048	K22174809	CHIP CAP.	GRM39B102M50PT	0.001uF	50V	B
C 1049	K22174809	CHIP CAP.	GRM39B102M50PT	0.001uF	50V	B

C01001 H7900270 CERAMIC OSC CSB800K

D 1001	G2070009	DIODE	1SS184 TE85R
D 1002	G2070026	DIODE	1SS196 TE85R
D 1003	G2070066	LED	LT1EP53A
D 1004	G2070078	DIODE	IMN10 T108

DS1001	G6090076	LCD	FSD-8836		
J 1001	P1090370	CONNECTOR	HSJ0836-01-010		
J 1002	P1090369	CONNECTOR	HSJ0838-01-010		
PL1001	Q1000054	LAMP	N07656	35mA	6V
Q 1001	G1090985	IC	HD404808A09H		
Q 1002	G3070027	TRANSISTOR	1MH5 T108		
Q 1003	G1090922	IC	RH5VA45AA-T2		
Q 1004	G3111627G	TRANSISTOR	2SA1162GR TE85R		
Q 1005	G1090967	IC	CAT35C102K-TE10		
Q 1006	G3070020	TRANSISTOR	HC1F3P-T2		
Q 1007	G3070033	TRANSISTOR	DTC144EK T97		
Q 1008	G3327127G	TRANSISTOR	2SC2712GR TE85R		
Q 1009	G3111627G	TRANSISTOR	2SA1162GR TE85R		
Q 1010	G3070031	TRANSISTOR	DTC124TK T97		
R 1001	J24185473	CHIP RES.	RMC1/16 473JATP	47K	1/16W
R 1002	J24185103	CHIP RES.	RMC1/16 103JATP	10K	1/16W
R 1003	J24185104	CHIP RES.	RMC1/16 104JATP	100K	1/16W
R 1004	J24185683	CHIP RES.	RMC1/16 683JATP	68K	1/16W
R 1005	J24185104	CHIP RES.	RMC1/16 104JATP	100K	1/16W
R 1006	J24185104	CHIP RES.	RMC1/16 104JATP	100K	1/16W
R 1007	J24185331	CHIP RES.	RMC1/16 331JATP	330	1/16W
R 1008	J24185471	CHIP RES.	RMC1/16 471JATP	470	1/16W
R 1009	J24185105	CHIP RES.	RMC1/16 105JATP	1M	1/16W
R 1010	J24185333	CHIP RES.	RMC1/16 333JATP	33K	1/16W
R 1011	J24185223	CHIP RES.	RMC1/16 223JATP	22K	1/16W
R 1012	J24185473	CHIP RES.	RMC1/16 473JATP	47K	1/16W
R 1013	J24185223	CHIP RES.	RMC1/16 223JATP	22K	1/16W
R 1014	J24185472	CHIP RES.	RMC1/16 472JATP	4.7K	1/16W
R 1015	J24185103	CHIP RES.	RMC1/16 103JATP	10K	1/16W
R 1016	J24185100	CHIP RES.	RMC1/16 100JATP	10	1/16W
R 1Q17	J24185473	CHIP RES.	RMC1/16 473JATP	47K	1/16W
R 1018	J24185473	CHIP RES.	RMC1/16 473JATP	47K	1/16W
R 1019	J24185102	CHIP RES.	RMC1/16 102JATP	1K	1/16W
R 1020	J24185183	CHIP RES.	RMC1/16 183JATP	18K	1/16W
R 1021	J24185105	CHIP RES.	RMC1/16 105JATP	1M	1/16W
R 1022	J24185000	CHIP RES.	RMC1/16 000JATP	0	1/16W
R 1023	J24185474	CHIP RES.	RMC1/16 474JATP	470K	1/16W
R 1024	J24185102	CHIP RES.	RMC1/16 102JATP	1K	1/16W
R 1025	J24185103	CHIP RES.	RMC1/16 103JATP	10K	1/16W
R 1026	J24185103	CHIP RES.	RMC1/16 103JATP	10K	1/16W
R 1027	J24185332	CHIP RES.	RMC1/16 332JATP	3.3K	1/16W
R 1028	J24185473	CHIP RES.	RMC1/16 473JATP	47K	1/16W
R 1029	J24185471	CHIP RES.	RMC1/16 471JATP	470	1/16W
R 1030	J24185152	CHIP RES.	RMC1/16 152JATP	1.5K	1/16W
R 1031	J24185222	CHIP RES.	RMC1/16 222JATP	2.2K	1/16W
R 1032	J24205000	CHIP RES.	RMC1/10T 000J	0	1/10W
R 1033	J24205000	CHIP RES.	RMC1/10T 000J	0	1/10W
R 1034	J24205000	CHIP RES.	RMC1/10T 000J	0	1/10W
R 1035	J24205000	CHIP RES.	RMC1/10T 000J	0	1/10W
S 1001	N0190146	ROTARY SWICH	SRZW1G		
S 1002	N6090057	SLIDE SWITCH	SSSS22		
S 1003	N5090018	TACT SWITCH	KHH-15951		
S 1004	N5090018	TACT SWITCH	KHH-15951		
S 1005	N4090088	PUSH SWITCH	SPJ622N FI9		

CONTROL UNIT(No.1 ***)

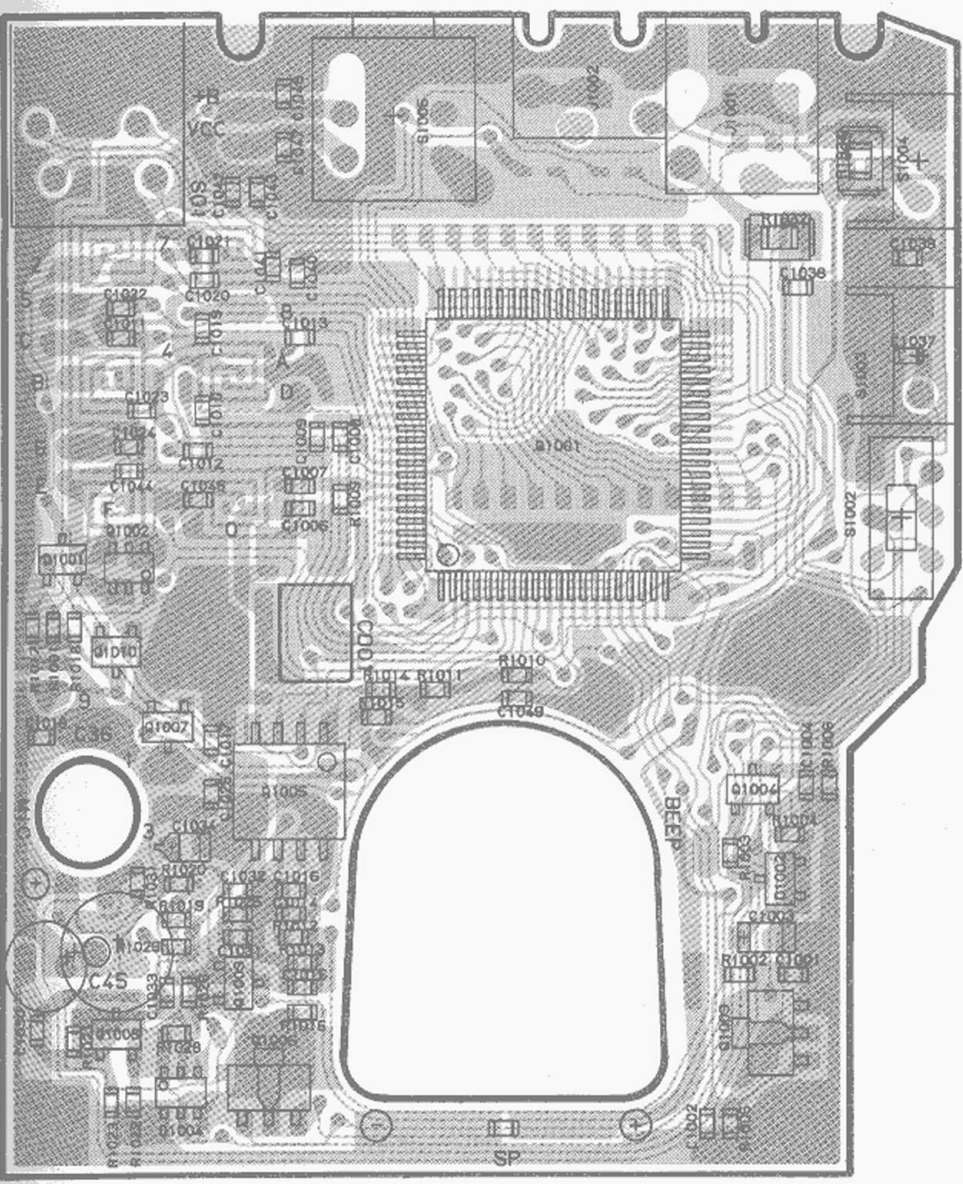

obverse view "mixed-component" side

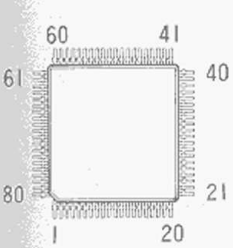

HD404808A09H(Q1001)

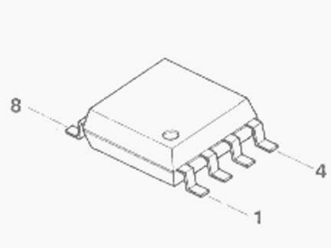

CAT35C102K(Q1005)

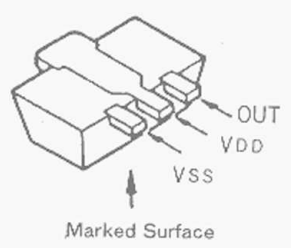

RH5VA45AA(D5)(Q1003)

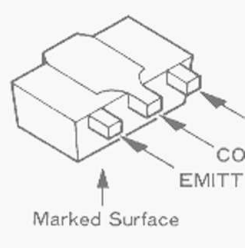

HC1F3P(CS)

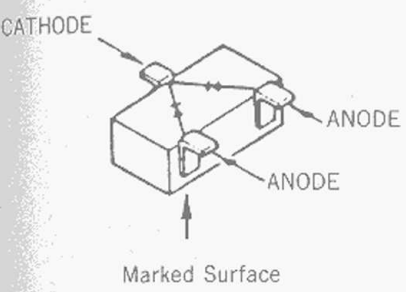

ISS184(B3)(D1001)

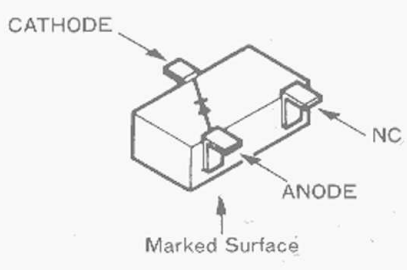

ISS196(G3)(D1002)

ANODE
ANODE I

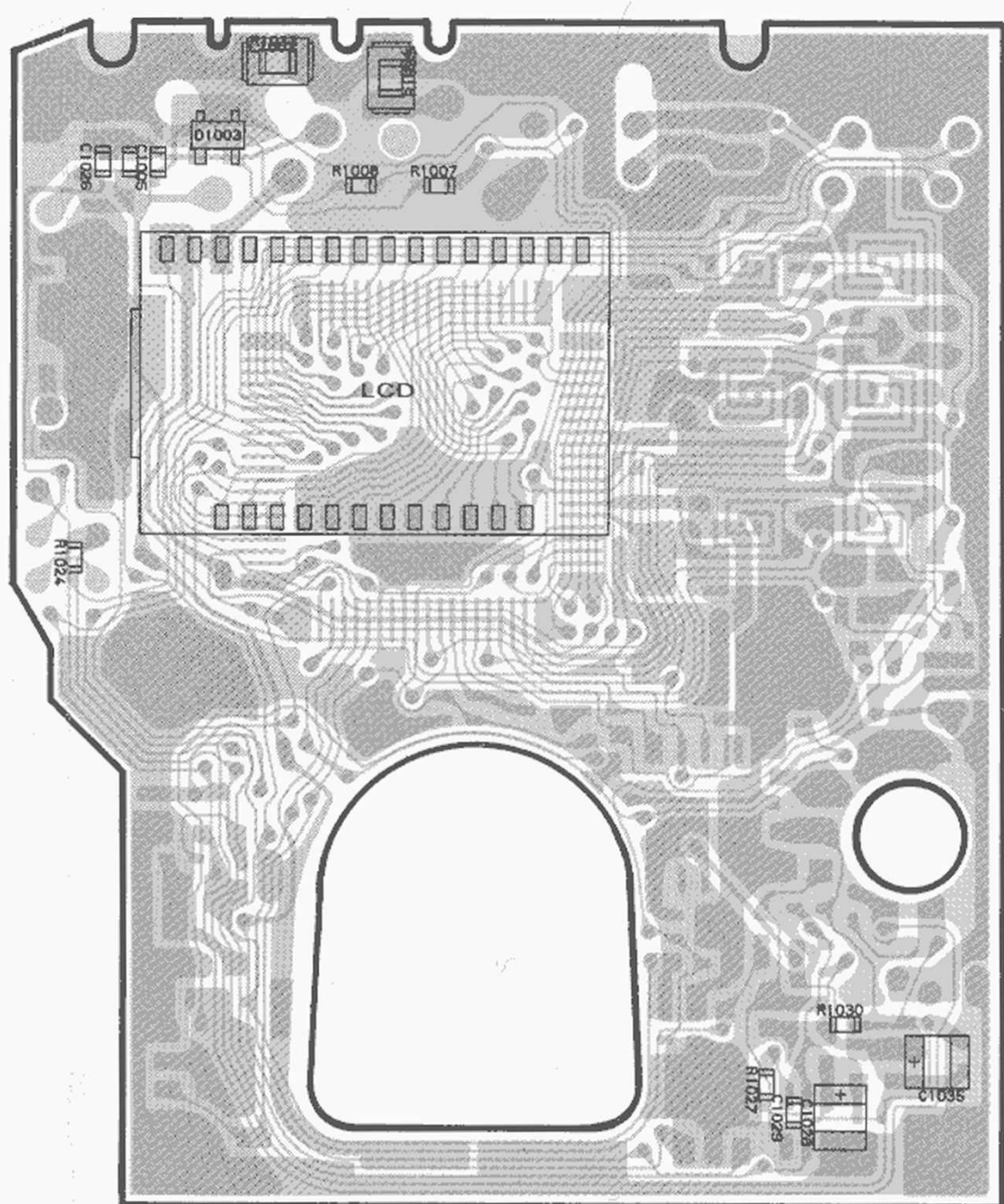

obverse view "chip-only" side

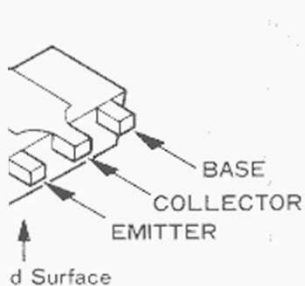

21F3P(CS)(Q1006)

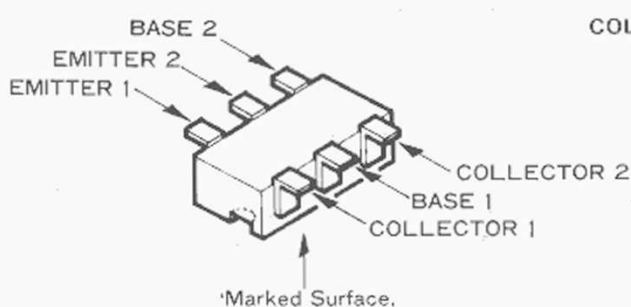

IMH5(H5)(Q1002)

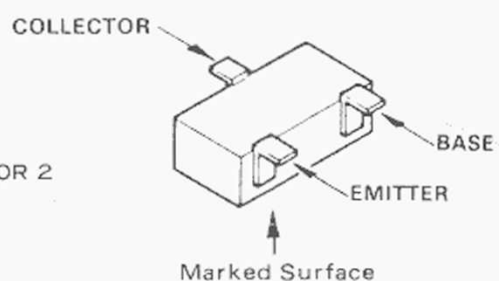

2SA1162GR(SG)(Q1004,1009)
DTC144EK(26)(Q1007)
2SC2712GR(LG)(Q1008)
DTC124TK(05)(Q1010)

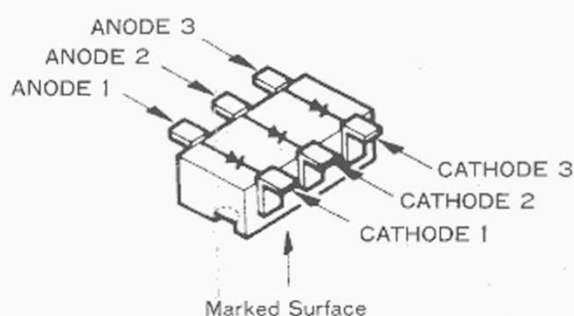

IMN10(N10)(D1004)

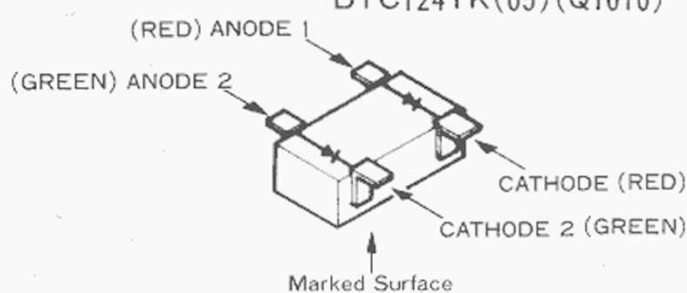

LT1EP53A(D1003)

CNTL UNIT
F3056102A

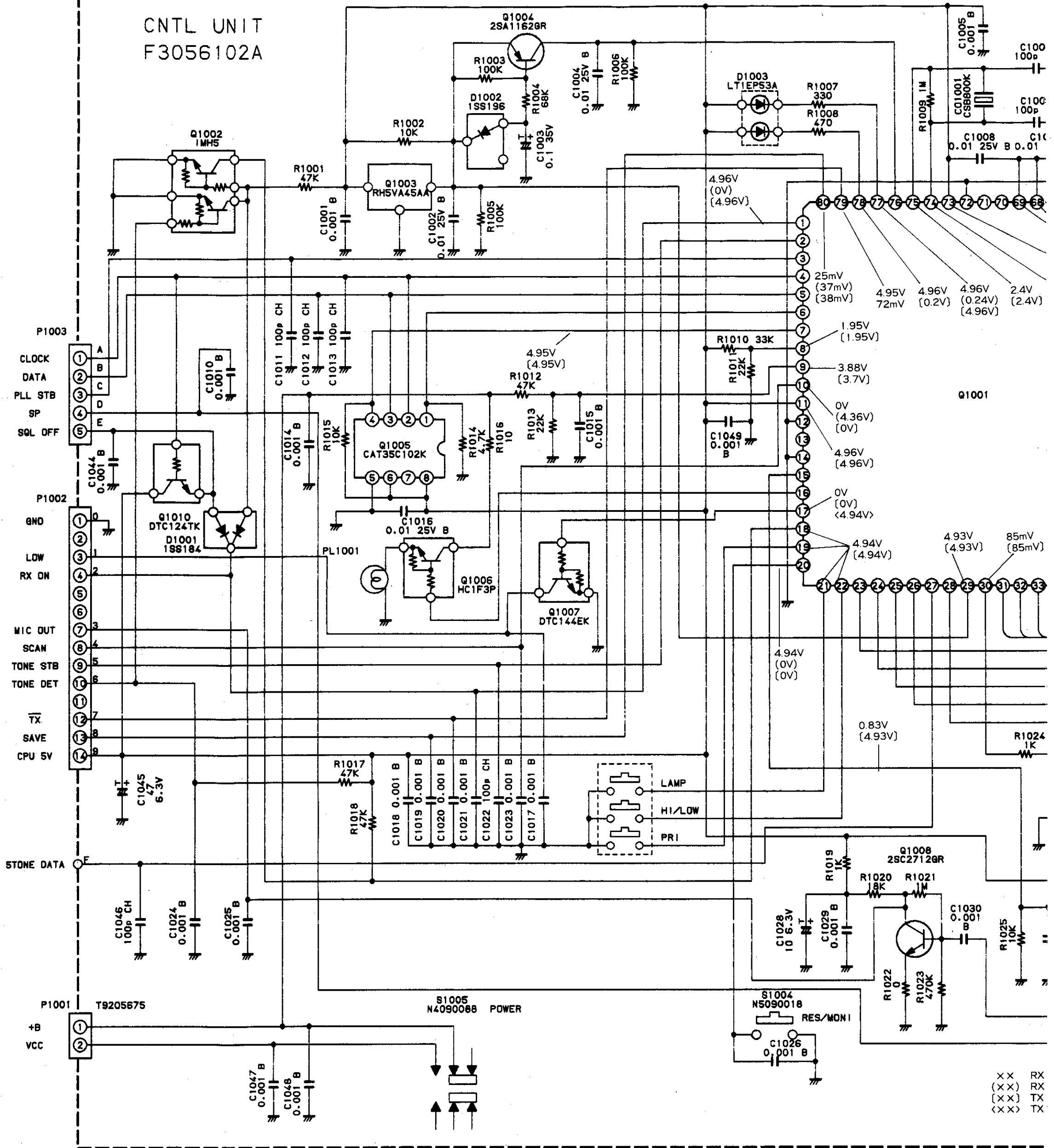

XX RX
(XX) RX
(XX) TX
(XX) TX

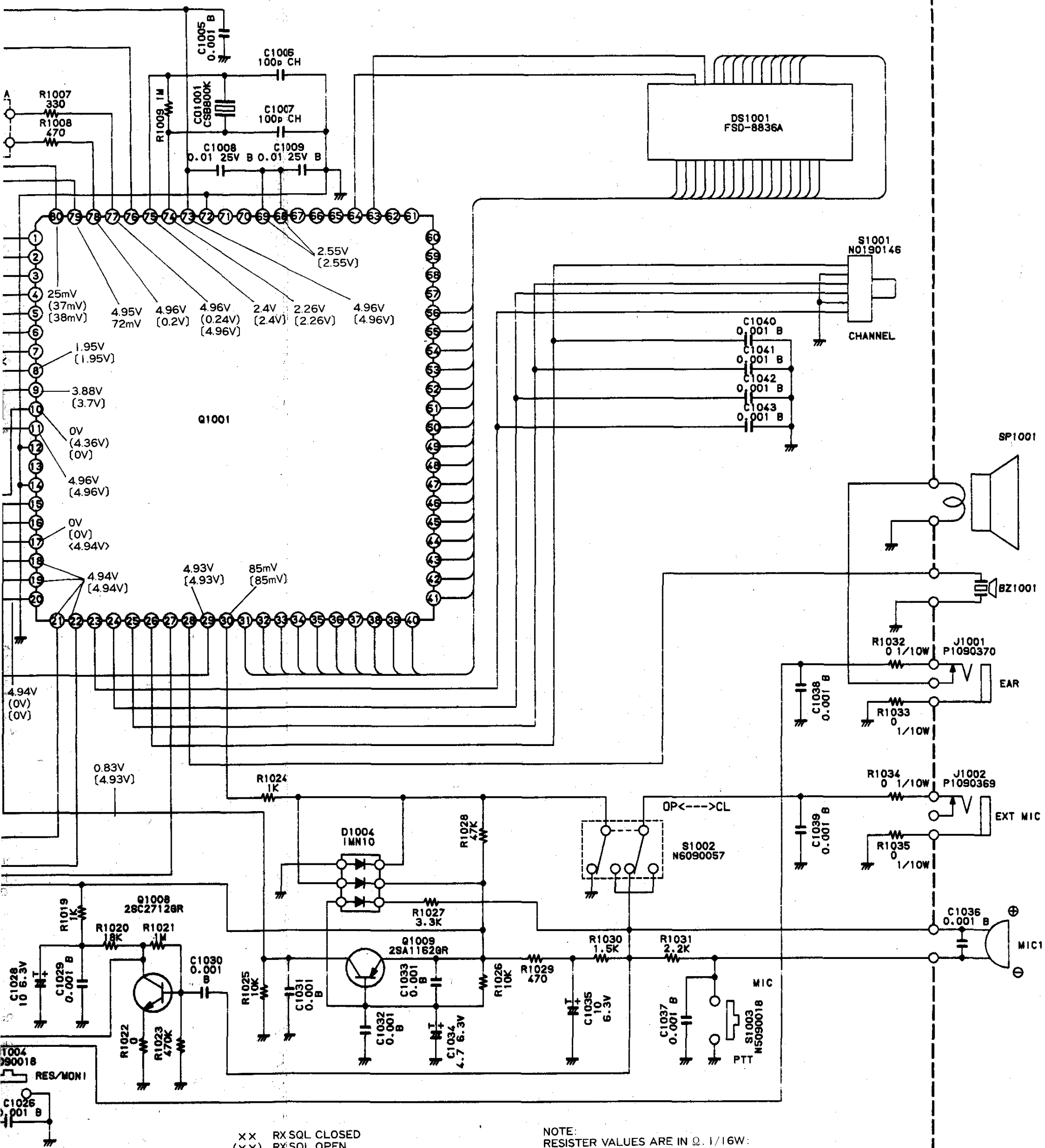

XX RXSQL CLOSED
 (XX) RXSQL OPEN
 (XX) TX Hi Power
 (XX) TX Low Power

NOTE:
 RESISTOR VALUES ARE IN Ω. 1/16W;
 CAPACITOR VALUES ARE IN μF. 50V;
 (T) CAPACITOR VALUES ARE TANTALUM;
 UNLESS OTHERWISE NOTED.

Component Applications

Control Unit

Location	Type	Nomenclature	Application
Q1001	VLSI IC	HD404808	Microprocessor
Q1002	Dual Transistor	IMH 5	Monitor Switch
Q1003	3-pin Regulator IC	RH5VA45AA	CPU Power Reset Control
Q1004	Transistor	2SA1162	CPU Power Reset Control
Q1005	EEPROM	CAT35C102K	Programmable Data Storage
Q1006	Transistor	HC1F3P	Pilot Lamp Driver
Q1007	Transistor	DTC144EK	High/Low Power Switch
Q1008	Transistor	2SC2712	Microphone Amplifier
Q1009	Transistor	2SA1162	PTT Switch
Q1010	Transistor	DTC124TK	Squelch Data Switch
D1001	Dual Diode	1SS184	Monitor Switch
D1002	Dual Diode	1SS196	CPU Power Reset
D1003	Dual LED	LTEP 53A	TX/BUSY Indicator

Mother Board

Q2001	FET	2SK302	Receiver RF Amp
Q2002	Transistor	2SC3120	Receiver First Mixer
Q2003	Transistor	2SC3356	VCO Buffer
Q2004	Transistor	2SC2954	Transmitter Driver
Q2005	Transistor	FA1A4M	Modulator Switch
Q2006	No such part		
Q2007	Transistor	2SC2712	Scan Inhibit During Power Save
Q2008	Analog IC	NJM386D	Receiver AF Amplifier
Q2009	Hybrid RF Module	M57796	Transmitter Power Amplifier
D2001	Dual Diode	1SS226	Receiver Input Overvoltage Protection
D2002–D2004	Varactor Diodes	1T32 × 3	Receiver BPF Tuning
D2005	Dual Diode	1SS184	VCO Output Selector
D2006	Dual Diode	1SS226	Low Power Bias Voltage

IF Unit

Location	Type	Nomenclature	Application
Q301	Transistor	2SC2620	IF Amplifier
Q302	Analog IC	TK10487	FM Receiver 2nd LO, IF Amp, Detector & Noise Amp
D301	Dual Diode	1SS226	IF Limiter
D302	Dual Diode	1SS226	Noise Detector

PLL Unit

Q401	CMOS IC	MC12017	PLL prescaler
Q402	Analog IC	JLC1007	PLL Ref Oscillator, Divider & Phase Comparator

VCO (Oscillator & Buffer) Units

Q501	FET	2SK238	VCO
Q502	Transistor	2SC2759	VCO Buffer
D501	Schottky Diode	1SS110	Receiver bias switch
D502/D503	Varactor Diodes	1T33 × 2	Modulator

Regulator Unit

Q601	Transistor	2SB799ML	Receiver AF Supply DC Amplifier
Q602	Transistor	2SC2712	Receiver AF Supply DC Amplifier
Q603	Transistor	2SC2712	Receiver AF Muting Gate
Q604	3-pin Regulator	LM2931AZ-5.0	CPU Supply Regulator
Q605	Transistor	2SA1162	Power Saver 5V Supply Gate
Q606	Transistor	2SA1162	Transmitter 5V Supply Gate
Q607	Transistor	2SA1162	Receiver 5V Supply Gate
Q608	Transistor	2SC2712	PTT Inverter for Rx 5V Supply Gate
D601	Dual Diode	1SS272	Bias & Diode OR for AF Muting Gate
D602	Zener Diode	RD10EB1	Receiver AF Supply Regulator
D603	Dual Diode	1SS184	Diode OR for AF Muting Gate

Microphone Unit

Location	Type	Nomenclature	Application
Q701	Quad Opamp	NJM2902	Microphone AF Amp, IDC & LPF

Antenna Switching Unit

Q901	Transistor	2SB799ML	Transmitter Supply Pass
Q902/Q903	Transistor	2SC2712 × 2	Transmitter Supply Regulator
Q904	Transistor	2SC2712	Transmitter Power Control
Q905	Transistor	2SB799ML	Transmitter Power Control
D901/D902	Diodes	1SS53 × 2	Antenna Switch
D903	Dual Diode	1SS226	Receiver Input Overvoltage Protector

One of these MICROPHONE will be supplied is per local requirement.

MH-18A2B (Miniature Speaker Microphone)

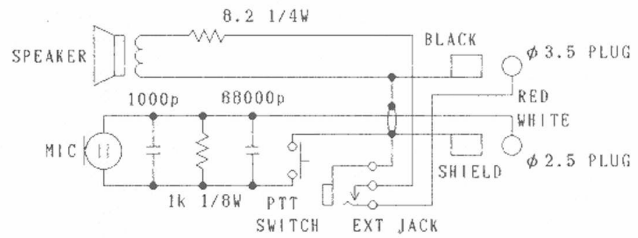

CIRCUIT DIAGRAM

MH-12A2B (External Hand Speaker Microphone)

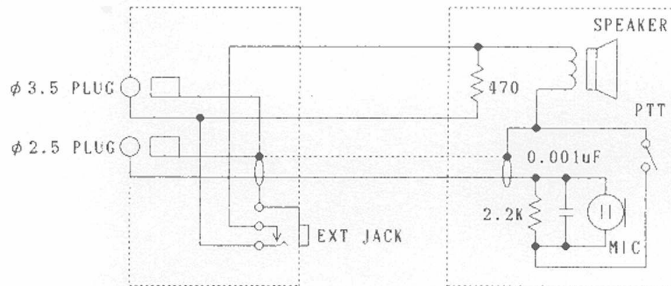
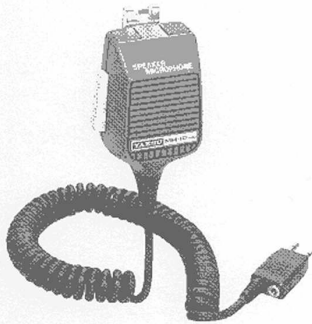

CIRCUIT DIAGRAM

MH-19A2B (Earpiece Microphone)

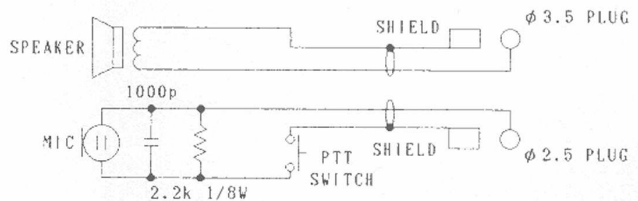
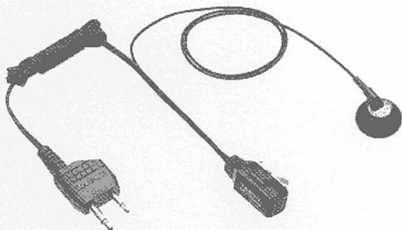

CIRCUIT DIAGRAM

Receiver

Set up the test equipment as shown below for receiver alignment.

- (1) With the transceiver set to band center channel 3, and the RF signal generator tuned to the same frequency, set the generator for ± 3.5 kHz deviation of 1-kHz tone modulation, and set the output level for 40 dB μ at the antenna jack.
- (2) Adjust T2001 through T2004 on the Mother Board for optimum SINAD.
- (3) After adjusting the transformers, generator level should be 0.2 μ V or less for 12dB SINAD.

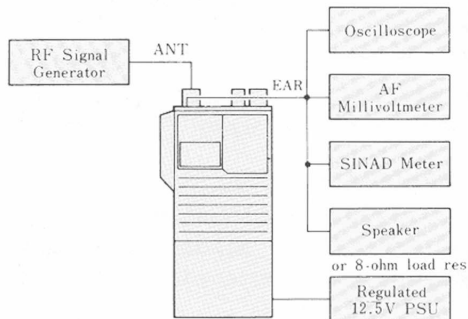

RECEIVER ALIGNMENT SETUP

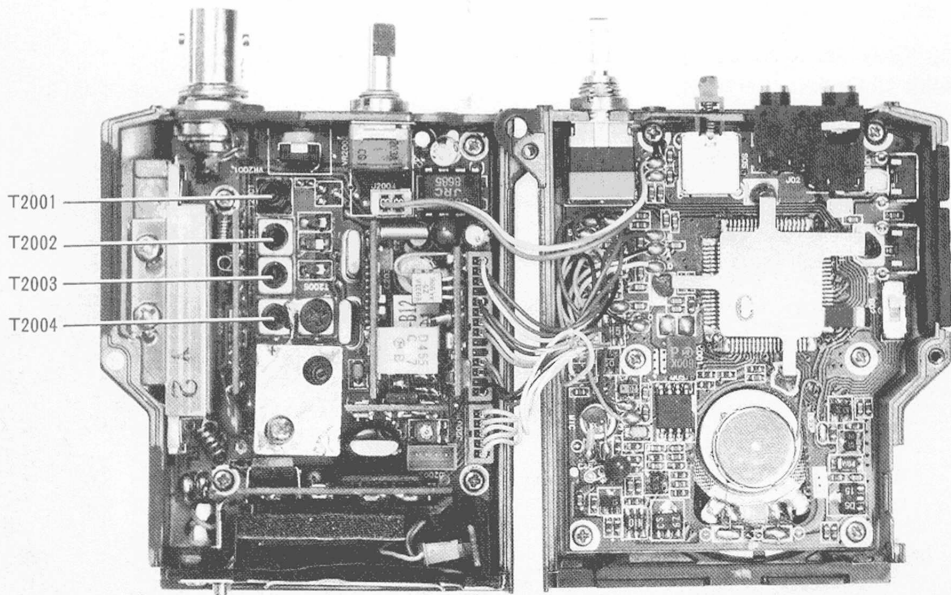

RECEIVER SECTION ALIGNMENT POINTS

Transmitter Output Power

- (1) Set the transceiver to band center channel 2, select High power output, and confirm at least 5 watts output with less than 1.6A of supply current.
- (2) Now select Low power output, and adjust VR2005 on the Mother Board for 0.4 to 0.7 watts output.

PLL Reference Frequency

With the transceiver tuned to band center, adjust TC401 on the PLL Unit, if necessary, so the display frequency matches the frequency counter when transmitting.

Modulation Level

- (1) With the transceiver tuned to band center, adjust the AF generator for 25-mV output at 1 kHz to the MIC jack.
- (2) Adjust VR2004 on the Mother Board for ± 4.3 -kHz deviation on the deviation meter.

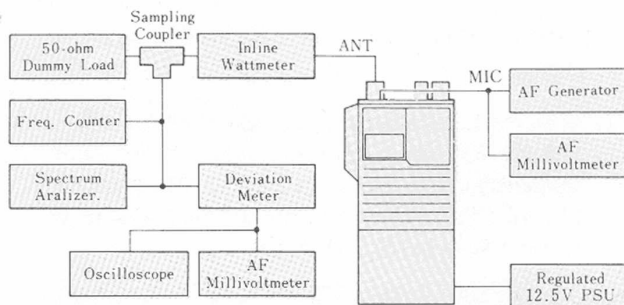

TRANSMITTER ALIGNMENT SETUP

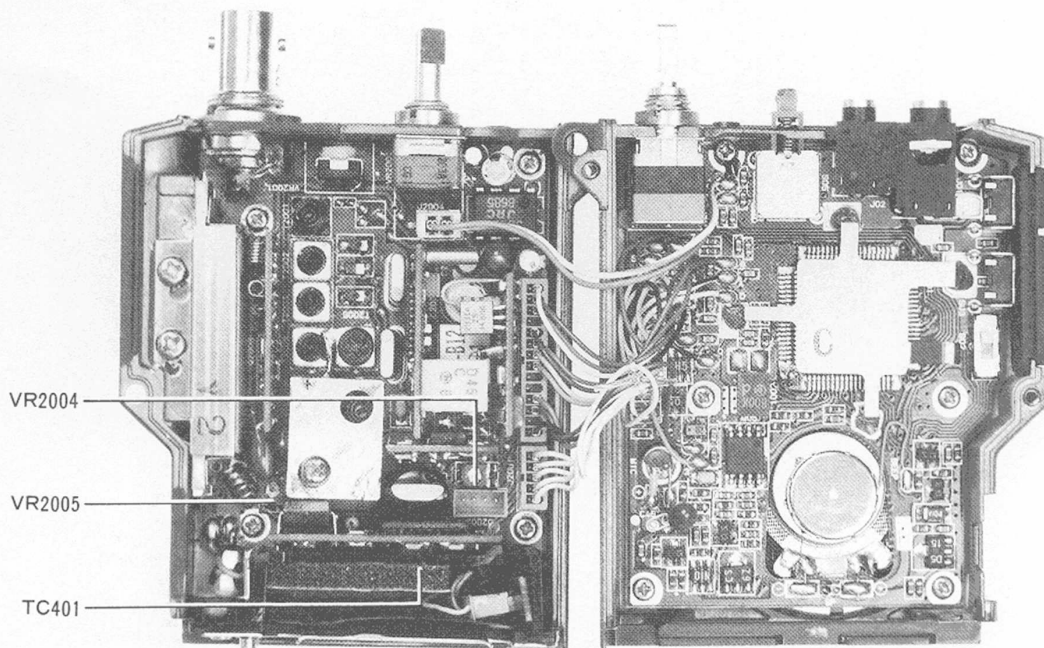

TRANSMITTER SECTION ALIGNMENT POINTS

ALIGNMENT

The FTH-2008 has been aligned at the factory for the specified performance across the frequency range specified for each version. Realignment should therefore not be necessary except in the event of a component failure, or alteration of version. All component replacement and service should be performed only by an authorized Yaesu representative, or the warranty policy may be voided.

Required Test Equipment

- IBM PC®/compatible Computer
- Yaesu FRB-2 Service Kit, with CE-2 Channel Programming Diskette
- RF Signal Generator with calibrated output level at 200 MHz

- Deviation Meter (linear detector)
- Oscilloscope
- AF Millivoltmeter
- SINAD Meter
- Inline Wattmeter with 5% accuracy at 200 MHz
- Regulated DC Power Supply adjustable from 4 to 17V, 2A
- 50- Ω Non-reactive Dummy Load: 10W at 200 MHz
- Frequency Counter: ± 0.2 ppm accuracy at 200 MHz
- AF Signal Generator
- DC Voltmeter: high impedance

Case Disassembly

- Make sure the transceiver is off. Remove the hard or soft case, if used, and remove the battery pack.
- Remove the four screws affixing the battery spring plate on the bottom of the transceiver, and carefully remove the plate and black inner dust cover.
- Pull off the **CHANNEL** and **VOL** knobs, and remove the four screws affixing the top panel. Remove the panel and rubber gasket under it.
- Remove the two screws affixing the front and rear halves of the case, and gently separate the halves, using care not to stress the interconnecting wires.

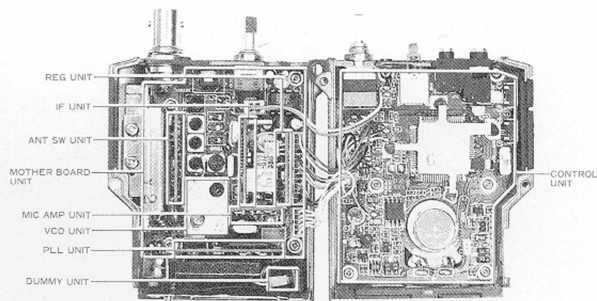

Before beginning alignment, connect the transceiver and PC to the FRB-2 Connection Box as described in the *Channel Programming* chapter, and download the EEPROM data from the transceiver to the computer. Then store this data in a disk file so that it can be uploaded when alignment is finished.

Next determine which version transceiver (A, B or C) is being aligned. The version letter is indicated on the battery spring plate (visible when the battery is removed). You should find a corresponding data file on the computer disk for the transceiver version you are aligning, containing channel settings for the high edge, middle and low edge of that version's frequency range in channels 1, 2 and 3, respectively. Upload this file to the transceiver.

PLL & Transmitter

Set up the test equipment as shown below for transmitter alignment. Adjust the supply voltage to 12.5V for all steps.

PLL VCV (Varactor Control Voltage)

- (1) Connect the DC voltmeter between C416 on the PLL Unit and chassis ground.
- (2) Set the transceiver to high band edge channel 1. Key the transmitter and adjust transformer T501 on the VCO Buffer Unit for $3.8 \pm 0.1V$ on the voltmeter.
- (3) While receiving on the high band edge, adjust trimmer TC501 on the VCO Buffer Unit for $3.8 \pm 0.1V$.
- (4) Set the transceiver to low band edge channel 3, and confirm the low-end VCV is 0.8V while transmitting, and 0.3V while receiving.

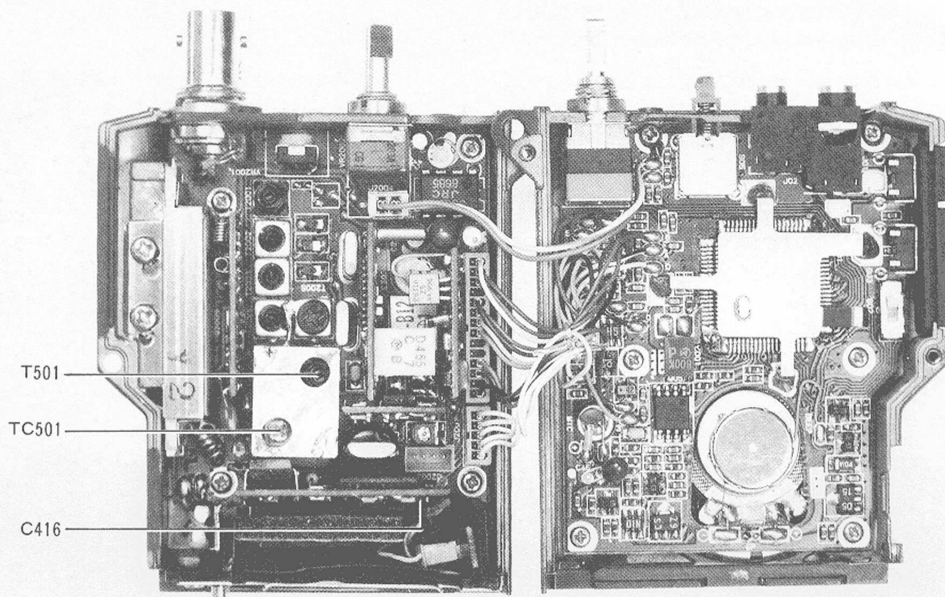

PLL SECTION ALIGNMENT POINTS